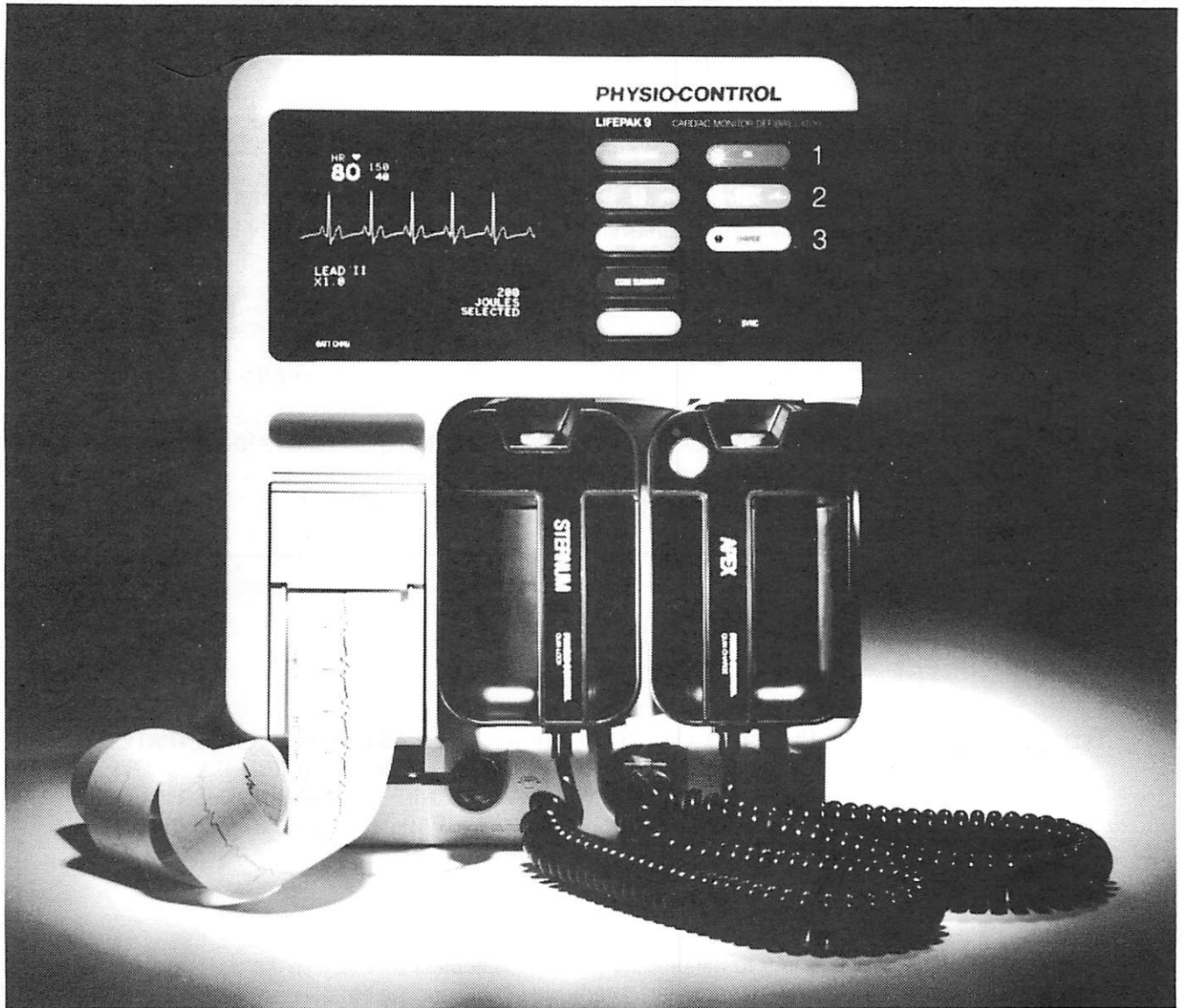


PHYSIO  
CONTROL

# LIFEPAK<sup>®</sup> 9 defibrillator/monitor



---

## Service Manual

Manual No. 803763-06

August 1993

---

### Corporate Headquarters:

11811 Willows Road Northeast  
Post Office Box 97006  
Redmond, WA 98073-9706 USA  
Telephone: 206/867-4000  
Toll Free: 800/442-1142 or 800/426-8047  
Telex: 990211 D PHYSIO RDMD  
Telefax: 206/883-2988

**Part No.** \_\_\_\_\_

**Serial No.** \_\_\_\_\_

**About This Manual:** This Service Manual is intended for use by technical service personnel. It describes how to maintain, test, troubleshoot, and repair the LIFEPAK 9 defibrillator/monitor.

A separate publication, the **Operating Instructions**, is intended for use by physicians, clinicians, and emergency care personnel. It provides step-by-step instructions for all operating features of the LIFEPAK 9 defibrillator/monitor as well as operator-level testing and maintenance.

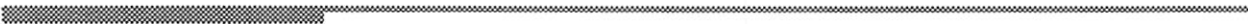
**Trademarks**

PHYSIO-CONTROL®, LIFEPAK®, FAST-PATCH®, LIFE•PATCH®, QUIK-LOOK®, DERMA JEL®, SAS (SHOCK ADVISORY SYSTEM)™, CODE SUMMARY™, and PARTSLINE™ are trademarks of the Physio-Control Corporation, 11811 Willows Road N.E., PO Box 97006, Redmond, WA 98073-9706.

**Warranty**

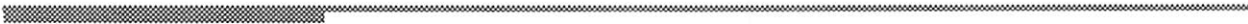
Refer to the product warranty statement included in the accessory kit shipped with the product. Duplicate copies may be obtained in the USA by calling the Physio-Control PARTSLINE at 1-800-442-1142. Outside the USA, contact your local Physio-Control sales or service office.

# Table of Contents



## Safety Information

Introduction .....	xii
Terms .....	xii
Warnings .....	xiii
Symbols .....	xiv



## General Information

Service Information .....	xv
Effective Publication Dates .....	xvi
Configuration Information .....	xvii
Content Overview .....	xviii



## Description 1

Introduction .....	1-1
Physical Description .....	1-1
Functional Description .....	1-6
Theory of Operation .....	1-8
Power Supply PCB Assembly (803726) .....	1-8
Power-On .....	1-8
Regulation .....	1-8
Overvoltage Protection .....	1-8
Output Isolation .....	1-8
Battery .....	1-8
BATT CHRG Indicator .....	1-9

Power Conversion PCB Assembly (803724) .....	1-9
Power Control .....	1-9
Logic Power Monitor .....	1-10
Switching Power Supply .....	1-11
External Control Input .....	1-11
Energy Storage Capacitor Charger .....	1-11
Low Energy Charge Rate .....	1-12
Capacitor Charge Control .....	1-13
Energy Transfer .....	1-13
Energy Dump .....	1-14
Energy Monitor .....	1-15
Serial Data Interface .....	1-15
Analog Voltage Evaluation .....	1-15
Charge LED Drive .....	1-16
Interconnect PCB Assembly (803761) .....	1-16
Main PCB Assembly (803715) .....	1-17
Preamp .....	1-19
System Controller .....	1-24
Display/Recorder Interface .....	1-25
Display PCB/CRT Assembly (803706) .....	1-32
Video Signal Amplifier .....	1-34
Frame Sweep Generator .....	1-34
Raster Scan Oscillator .....	1-34
Raster Voltage Generator .....	1-34
Raster Generator .....	1-35
CRT Bias Generator .....	1-35

---

## Operation      2

<b>Introduction</b> .....	2-1
<b>Controls and Indicators</b> .....	2-1
<b>Option Settings</b> .....	2-7
Test Menu .....	2-7
Setup Menu .....	2-8
Info Menu .....	2-9
<b>Clock Setting Procedure</b> .....	2-10

<b>Special Handling Procedures for Static Sensitive Devices (SSDs)</b> .....	4-5
Look for SSD Symbol .....	4-5
Use Static-Dissipative Mat .....	4-6
Wear Wrist Strap .....	4-6
Transport and Store PCBs Properly .....	4-6
Keep Work Area Static-Free .....	4-6
Test Work Area Routinely .....	4-6
<b>Disassembly Procedures</b> .....	4-6
Battery Pack Removal .....	4-7
Front Panel Bezel and Keypad Assembly Removal .....	4-7
Strip Chart Recorder Removal .....	4-8
Case Separation .....	4-8
Power Conversion PCB Removal .....	4-10
Main PCB Removal .....	4-10
Display PCB/CRT Assembly Removal .....	4-10
Power Supply Removal .....	4-11
Interconnect PCB Removal .....	4-11
<b>Inspection Techniques</b> .....	4-11
Exterior Inspection .....	4-11
Interior Inspection .....	4-11
<b>Tools and Materials for Cleaning and Repair</b> .....	4-13
<b>Cleaning Procedures</b> .....	4-13
External Cleaning .....	4-13
Interior Cleaning .....	4-14
<b>PCB Repair Precautions</b> .....	4-15
<b>Preparation for Storage or Shipping</b> .....	4-16

---

## Parts Lists/ Schematics

5

<b>Introduction</b> .....	5-1
Parts List .....	5-1
Component Layouts or Exploded Views .....	5-2
Schematic Diagrams .....	5-2
<b>How to Order Parts</b> .....	5-2
<b>Supplies and Accessories</b> .....	5-5

---

## Component Reference

6

<b>Introduction</b> .....	6-1
<b>Component Reference Diagrams</b> .....	6-3

---

## Index

Index-1

## List of Figures

<b>Description</b>	<b>1</b>	Figure 1-1	LIFEPAK 9 defibrillator/monitor . . . . .	1-2
		Figure 1-2	LIFEPAK 9 defibrillator/monitor Functional Block Diagram . . . . .	1-7
		Figure 1-3	Power Conversion PCB Block Diagram . . . . .	1-10
		Figure 1-4	Main PCB Block Diagram . . . . .	1-18
		Figure 1-5	Preamp Timing . . . . .	1-20
		Figure 1-6	Echo Period . . . . .	1-23
		Figure 1-7	Control Line Timing . . . . .	1-27
		Figure 1-8	Character Cell Locations . . . . .	1-28
		Figure 1-9	Video Intensity . . . . .	1-29
		Figure 1-10	Printhead Assembly . . . . .	1-31
		Figure 1-11	Display PCB/CRT Assembly Block Diagram . . . . .	1-33
		Figure 1-12	Display Scanning . . . . .	1-33
<b>Operation</b>	<b>2</b>	Figure 2-1	Front Panel Controls and Indicators . . . . .	2-2
		Figure 2-2	Rear Panel Controls, Indicators, and Connectors . . . . .	2-6
		Figure 2-3	Test Menu . . . . .	2-7
		Figure 2-4	Setup Menu . . . . .	2-8
		Figure 2-5	Info Menu . . . . .	2-9
		Figure 2-6	Clock Set Display . . . . .	2-10
<b>Testing</b>	<b>3</b>	Figure 3-1	Power-On Display . . . . .	3-5
		Figure 3-2	Test Menu . . . . .	3-6
		Figure 3-3	Setup Menu . . . . .	3-6
		Figure 3-4	Display with Flatline ECG Trace . . . . .	3-8
		Figure 3-5	1mV CAL Pulse . . . . .	3-9
		Figure 3-6	Example of CODE SUMMARY Printout . . . . .	3-15
		Figure 3-7	Test Connections for Ground Resistance Measurement . . . . .	3-16
		Figure 3-8	Test Connector J3 . . . . .	3-23
		Figure 3-9	Test Menu . . . . .	3-25
		Figure 3-10	Output Waveform . . . . .	3-29
		Figure 3-11	Display PCB Assembly Potentiometer Locations . . . . .	3-30
		Figure 3-12	Power Supply Calibration . . . . .	3-33
		Figure 3-13	Recorder Calibration Adjustments Location . . . . .	3-34
		Figure 3-14	Test Signal Setup for Function Generator . . . . .	3-36
<b>Service and Maintenance</b>	<b>4</b>	Figure 4-1	Front Panel Removal . . . . .	4-7
		Figure 4-2	Connector Locations . . . . .	4-9
		Figure 4-3	LIFEPAK 9 defibrillator/monitor Shipping Assembly . . . . .	4-16

Figure 5-1	LIFEPAK 9 defibrillator/monitor Final Assembly	5-13
Figure 5-2	Interconnect Diagram	5-14
Figure 5-3	Main PCB Assembly	5-24
Figure 5-4	Power Supply PCB Assembly	5-32
Figure 5-5	Power Conversion PCB Assembly	5-41
Figure 5-6	Interconnect PCB Assembly	5-47
Figure 5-7	Keypad Assembly	5-50
Figure 5-8	Rear Panel Membrane Switch	5-51
Figure 5-9	Strip Chart Recorder Assembly	5-53
Figure 5-10	Transfer Relay Assembly	5-55
Figure 5-11	Paddle Assembly	5-56
Figure 5-12	Display PCB/CRT Assembly	5-59
Figure 5-13	Power Supply PCB/AC Receptacle/Ground Wire Harness	5-68
Figure 5-14	Power Conversion PCB/Power Supply PCB/Battery Wire Harness	5-69
Figure 5-15	Battery Sensor/Power Supply PCB Wire Harness	5-70
Figure 5-16	High Voltage Connector Cable Assembly	5-71
Figure 5-17	Main PCB/Display Cable Assembly	5-72
Figure 5-18	Main PCB/Recorder Cable Assembly	5-73
Figure 5-19	Interconnect PCB/Keypad Cable Assembly	5-74
Figure 5-20	Main PCB/Patient Connector Wire Harness	5-75
Figure 5-21	AC Receptacle/Ground Wire Harness	5-76
Figure 5-22	AC Receptacle Wire Harness	5-76
Figure 5-23	Test Load Contact/Resistor Wire Harness	5-77
Figure 5-24	Power Conversion PCB/Reed Assy Wire Harness	5-77
Figure 5-25	Power Conversion PCB/Dump Relay Wire Harness	5-78
Figure 5-26	Power Conversion PCB/Charge Relay Negative Wire Harness	5-79
Figure 5-27	Power Conversion PCB/Charge Relay Positive Wire Harness	5-79
Figure 5-28	Main PCB/Sternum Relay Wire Harness	5-80
Figure 5-29	Main PCB/Apex Relay Wire Harness	5-80
Figure 5-30	Storage Capacitor Positive/Relay Wire Harness	5-81
Figure 5-31	Storage Capacitor Negative/Relay Wire Harness	5-81
Figure 5-32	ECG Out Wire Harness	5-82
Figure 5-33	Recorder/Bracket Ground Wire Harness	5-83
Figure 5-34	Power Supply Bracket/Ground Wire Harness	5-84
Figure 5-35	Defibrillation Adapter	5-86
Figure 5-36	Test Load High Voltage Wire Harness (W1)	5-88
Figure 5-37	Test Load High Voltage Wire Harness (W2)	5-88
Figure 5-38	Pushbutton Switch Wire Harness	5-89
Figure 5-39	High Voltage Connector Cable Assembly	5-90

**Component  
Reference  
Diagrams**

6

Figure 6-1	Buffer .....	6-3
Figure 6-2	Real-Time Clock .....	6-3
Figure 6-3	A/D Converter .....	6-4
Figure 6-4	D/A Converter .....	6-4
Figure 6-5	Counter .....	6-5
Figure 6-6	Counter .....	6-5
Figure 6-7	Decoder .....	6-6
Figure 6-8	Decoder .....	6-6
Figure 6-9	Deflection Circuit .....	6-7
Figure 6-10	EPR0M .....	6-7
Figure 6-11	D-Type Flip-Flop .....	6-8
Figure 6-12	D-Type Flip-Flop .....	6-8
Figure 6-13	D-Type Flip-Flop .....	6-9
Figure 6-14	J-K Flip-Flop .....	6-9
Figure 6-15	Display Gate Array .....	6-10
Figure 6-16	Recorder Gate Array .....	6-10
Figure 6-17	Microprocessor .....	6-11
Figure 6-18	Pulse-Width Modulator .....	6-11
Figure 6-19	Multivibrator .....	6-12
Figure 6-20	Multivibrator .....	6-12
Figure 6-21	Oscillator .....	6-13
Figure 6-22	Shift Register .....	6-13
Figure 6-23	Pulse-Width Regulator .....	6-14
Figure 6-24	Static RAM, 32k x 8 .....	6-14
Figure 6-25	Analog Switch .....	6-15
Figure 6-26	Analog Switch .....	6-15
Figure 6-27	Voltage Regulator .....	6-16



## List of Tables

<b>Description</b>	<b>1</b>	Table 1-1	LIFEPAK 9 defibrillator/monitor Specifications ..	1-3
		Table 1-2	Main PCB Functional Circuits .....	1-17
		Table 1-3	Preamp Pulse Widths .....	1-21
		Table 1-4	Display/Recorder Microprocessor I/O Lines .....	1-26
<b>Operation</b>	<b>2</b>	Table 2-1	Front Panel Controls and Indicators .....	2-3
		Table 2-2	Rear Panel Controls, Indicators and Connectors ..	2-6
<b>Testing</b>	<b>3</b>	Table 3-1	PIP Test Equipment .....	3-2
		Table 3-2	Delivered Energy Tolerances .....	3-14
		Table 3-3	Maximum Leakage Current for 120Vac and 60Hz	3-17
		Table 3-4	Maximum Leakage Current for 230Vac and 50Hz	3-17
		Table 3-5	Test and Calibration Test Equipment .....	3-21
		Table 3-6	Power Conversion PCB Voltage Checks .....	3-23
		Table 3-7	Low Battery Thresholds .....	3-24
		Table 3-8	Defibrillator Calibration Measurement Ranges ...	3-26
		Table 3-9	Error Codes .....	3-40
<b>Service and Maintenance</b>	<b>4</b>	Table 4-1	Inspection Techniques .....	4-12
		Table 4-2	Tools and Materials for Cleaning and Repair ....	4-13
<b>Parts Lists/Schematics</b>	<b>5</b>	Table 5-1	LIFEPAK 9 defibrillator/monitor Major Assemblies .....	5-3
		Table 5-2	Defibrillation Adapter Assemblies .....	5-4
		Table 5-3	Reference Designator Key .....	5-4
		Table 5-4	Supplies and Accessories .....	5-5
<b>Component Reference</b>	<b>6</b>	Table 6-1	Component Reference Diagrams .....	6-1

# Safety Information

---

## Introduction

This safety information includes terms and symbols used in this manual or on the equipment to alert both operating and service personnel of recommended precautions in care, use and handling of this specialized medical equipment.

Refer to NFPA (National Fire Protection Association) 99-1990, *Health Care Facilities*, and NFPA 70-1990, *National Electrical Code*, for specific guidelines on the standards and practices for health-care instruments and environments.

---

## Terms

Certain terms are used in this manual, or on the equipment. Familiarize yourself with their definitions and significance.

**Danger:** Immediate hazards which **will** result in severe personal injury or death.

**Warning:** Hazards or unsafe practices which **could** result in severe personal injury or death.

**Caution:** Hazards or unsafe practices which **could** result in minor personal injury or product damage.

**Note:** Points of particular interest for more efficient or convenient instrument operation. Additional information or explanation concerning the subject under discussion.

---

## Warnings

Following are descriptions of general hazards and unsafe practices that could result in death, severe injury or product damage. Specific warnings and cautions not appearing in this section are found throughout the manual.

### Shock Hazard

When charged and discharged, the LIFEPAK 9 defibrillator/monitor discharges up to 360J of electrical energy through the defibrillator paddles. Unless discharged properly as described in this manual, this electrical energy may cause personal injury or death. Do not attempt to perform this procedure unless you are thoroughly familiar with the operation of the LIFEPAK 9 defibrillator/monitor and all accessories.

### Possible Arcing and Paddle Damage

When discharging the defibrillator into the internal test load, make sure the standard paddles are securely and properly stored in the paddle storage area (STERNUM paddle on the left, APEX paddle on the right). This helps prevent arcing and formation of pits on paddle electrode surfaces. Pitted or damaged paddle electrode surfaces can cause patient skin burns during defibrillation.

### Possible Fire or Explosion

Do not operate this product in oxygen-enriched environments or in the presence of flammable gases or anesthetics. Explosion or fire can result. Refer to NFPA (National Fire Protection Association) 99-1990, *Health Care Facilities*, and NFPA 70-1990, *National Electrical Code*, before operating this product in the proximity of flammable gases or anesthetics.

### Safety Hazard

Do not mount the product directly above the patient. Place the product in a location where it cannot harm the patient if it should fall from its shelf or other mounting location.

### Electrical Hazard and Possible Equipment Failure

Do not operate equipment using damaged cables and wires. Broken or frayed wires, or loose snap fittings may cause interference or loss of signal and possible equipment failure. Perform frequent electrical and visual inspections on cables and wires. Pay particular attention to the point at which the wires enter the terminals. Repeated flexing at these points eventually causes the wire strands to break.

### Shock or Fire Hazard

Do not immerse any portion of the instrument in water or other fluids. Avoid spilling any fluids on the instrument or accessories.

### Possible Equipment Damage

Do not sterilize this product. Sterilization environments can cause serious damage. Do not autoclave or gas sterilize accessories unless manufacturer instructions clearly approve it.

**Safety Risk**

Do not substitute accessories. Use only recommended accessories listed in Table 5-4 shown on page 5-5. Substitution may cause the instrument to work improperly.

**Shock or Fire Hazard**

Make sure that all equipment is interconnected safely in accordance with NFPA (National Fire Protection Association) 70-1990, *National Electrical Code*.

*Note: Within certain governmental jurisdictions, all interconnected accessory equipment must be labeled by an approved testing laboratory. It is important that you verify and observe the required applications in your location. Check leakage current and grounding requirements after interconnecting this instrument with accessory equipment.*

---

**Symbols**

Any or all of the following symbols may appear in this manual or on the equipment:



Static Sensitive Device (SSD)



Additional information in Section 6, Component References



**DANGER** — high voltage present



**ATTENTION** — refer to manual for more information



Defibrillation protected, type CF patient connection



Defibrillation protected, type BF patient connection



Protective ground (earth) terminal



Fusible Link



Equipotentiality connector



Off (Power: disconnection from the mains)



On (Power: connection to the AC mains)



ECG Output

# General Information

---

## Service Information

Before attempting to clean or repair any assembly in this instrument, the technician should be familiar with the information provided in Section 4, **Service and Maintenance**.

If the instrument has been dropped, damaged, or abused, a qualified technician should complete the **Performance Inspection Procedure (PIP)** in Section 3, beginning on page 3-1, to confirm whether the instrument is operating within specifications. If calibration or more extensive testing is required, a qualified technician can perform the **Test and Calibration Procedure (TCP)** in Section 3. Component replacement and internal adjustments must be performed only by service personnel qualified by appropriate training and experience.

Use of non-Physio-Control defibrillation electrodes, batteries, accessories, or adapter devices may void Safety Agency Certifications and warranty.

For assistance in servicing the instrument in the US, call Physio-Control at 1-800-442-1142. In other countries contact the local Physio-Control representative.

## Effective Publication Dates

The effective publication date for each page of this manual is listed below.

Title	Page	Date
Trademark and Warranty	ii	August 1993
Table of Contents	iii thru vii	August 1993
List of Figures	viii thru ix	August 1993
List of Tables	xi	August 1993
Safety Information	xii thru xiv	August 1993
Terms	xii	August 1993
Warnings	xiii	August 1993
Symbols	xiv	August 1993
General Information	xv thru xviii	August 1993
Service	xv	August 1993
Effective Publication Dates	xvi	August 1993
Configuration Information	xvii	August 1993
Content Overview	xviii	August 1993
1 Description	1-1 thru 1-35	August 1993
2 Operation	2-1 thru 2-10	August 1993
3 Testing	3-1 thru 3-41	August 1993
4 Service and Maintenance	4-1 thru 4-16	August 1993
5 Part Lists/Schematics	5-1 thru 5-90	August 1993
6 Component Reference	6-1 thru 6-16	August 1993
Index	Index-1 thru Index-6	August 1993

## Configuration Information

This manual is current with the listed revision level of the following part numbers. The assemblies appear in the same order as in Table 5-1.

Assembly Name	Part Number	Rev
LIFEPAK 9 defibrillator/monitor	803800	H4
Main PCB Assembly	803715-11	C3
Power Supply PCB Assembly	803726-01	Orig7
Power Conversion PCB Assembly	803724-03	D6
Interconnect PCB Assembly	803761-02	C4
Keypad Assembly	803771	C3
Rear Panel Switch Membrane	803741-01	A1
Strip Chart Recorder Assembly	804189-00	B2
Transfer Relay Assembly	800240-14	U10
Paddle Assembly	802901-06	F
Display PCB/CRT Assembly	803706	A5
Power Supply PCB/AC Receptacle/Ground Wire Harness (W1)	803783-30	B5
Power Conversion PCB/Power SupplyPCB/Battery Wire Harness (W2)	803783-23	B5
Battery Sensor/Power Supply PCB Wire Harness (W3)	803783-24	B5
High Voltage Connector Cable Assembly (W4)	803756-13	D4
Main PCB/Monitor PCB Cable Assembly (W5)	803733-00	Orig1
Main PCB/Recorder Cable Assembly (W6)	803773-00	Orig1
Interconnect PCB/Keypad Cable Assembly (W7)	803772-00	Orig3
Main PCB/Patient Connector Wire Harness (W8)	803783-00	B5
AC Receptacle/Ground Wire Harness (W9)	803783-04	B5
AC Receptacle Wire Harness (W10)	803783-05	B5
Test Load Contact/Resistor Wire Harness (W11)	803783-06	B5
Power Conversion PCB/Reed Assembly Wire Harness (W12)	803783-07	B5
Power Conversion PCB/Dump Relay Wire Harness (W13)	803783-08	B5
Power Conversion PCB/Charge Relay Negative Wire Harness (W14)	803783-09	B5
Power Conversion PCB/Charge Relay Positive Wire Harness (W15)	803783-10	B5
Main PCB/Sternum Relay Wire Harness (W16)	803783-11	B5
Main PCB/Apex Relay Wire Harness (W17)	803783-12	B5
Storage Capacitor Positive/Relay Wire Harness (W18)	803783-13	B5
Storage Capacitor Negative/Relay Wire Harness (W19)	803783-14	B5
ECG Out Wire Harness (W20)	803783-15	B5
Recorder/Bracket Gound Wire Harness (W21)	803783-19	B5
Power Supply Bracket/Ground Wire Harness (W22)	803783-29	B5

Assembly Name	Part Number	Rev
Defibrillation Adapter	803747	B2
Test Load High Voltage Wire Harness	803774-03	A1
Test Load High Voltage Wire Harness	803774-04	A1
Pushbutton Switch Wire Harness	803774-05	A1
High Voltage Connector Cable Assembly	803756-09	D4

---

## Content Overview

This manual contains the following information:

- Section 1**      **Description:** This section details how the instrument works. Input signals, power supplies, PCB functions, and instrument outputs are described. Each PCB circuit description is accompanied by a block diagram to illustrate the major circuits. Circuit names in these block diagrams also appear in the appropriate schematics in Section 5.
- Section 2**      **Operation:** This section familiarizes the user with basic equipment function. It identifies Controls, Indicators, and Connectors, and screen menu options. This section is not intended to instruct the operator in the clinical use of the instrument; such detailed instructions are provided in the separate *Operating Instructions* manual.
- Section 3**      **Testing/Troubleshooting:** This section contains the Performance Inspection Procedure (PIP)—sequential steps to follow when performing an operational closed-case check of the equipment. A PIP checklist is provided which can be duplicated and used during testing. The Test and Calibration Procedure (TCP) in this section describes calibration and more extensive instrument testing; it also includes a checklist. The Troubleshooting Aids includes additional information to support troubleshooting.
- Section 4**      **Service and Maintenance:** This section provides Disassembly/Assembly Procedures for removing all major subassemblies. The procedures are referenced to numbered parts in the Final Assembly drawing in Section 5. This section includes instructions for inspecting, cleaning, maintaining, and repairing the instrument.
- Section 5**      **Parts Lists/Schematics:** This section contains a list of Supplies and Accessories, Illustrated Parts Lists, PCB Component Layouts, and Schematic Diagrams for all repairable assemblies.
- Section 6**      **Component Reference Diagrams:** An aid to troubleshooting, this section consists of Component Reference Diagrams for selected Integrated Circuits (ICs). The ICs in Section 6 are identified in the schematics in Section 5 with a large asterisk \*.



The recorder can print the ECG trace, time and date, ECG lead and size, heart rate, and SYNC (if activated). The recorder automatically prints for approximately 16 seconds when a heart rate violation occurs. When the CODE SUMMARY pushbutton is pressed, the recorder prints the stored CODE SUMMARY critical event record data, including event summary and recorded ECG trace data.

The ac line power fuses, a ground connector, and an ECG signal output connector are accessible at the rear panel. The LIFEPAK 9 defibrillator/monitor specifications are listed in Table 1-1.

**Table 1-1 LIFEPAK 9 defibrillator/monitor Specifications\***

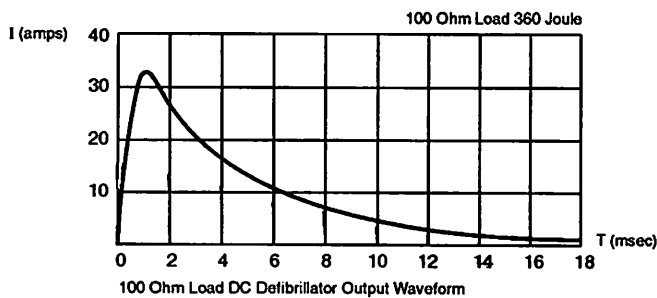
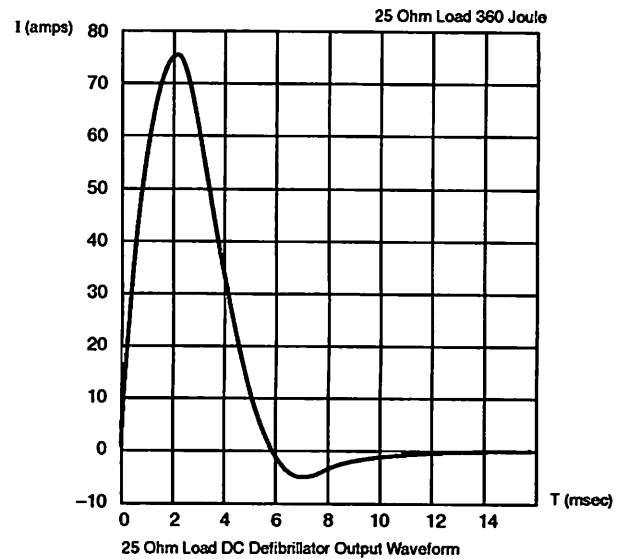
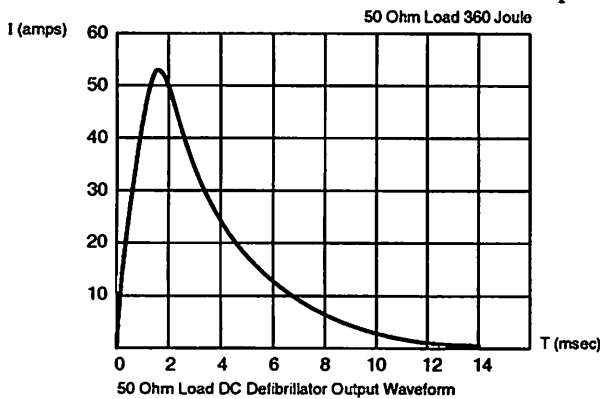
<b>ECG Monitor</b>	
ECG LEAD SELECTIONS INPUT	Std, Paddles, I, II, III. Isolated ECG via QUIK-LOOK defibrillator paddles, FAST-PATCH disposable defibrillation/ECG electrodes, or 3-lead patient cable.
PATIENT CABLE LENGTH COMMON MODE REJECTION	Total length 4.0m (13ft): cable 3.1m (10ft), leads 0.9m (3ft). 100dB minimum with respect to chassis ground and 65dB minimum with respect to isolated ground when measured at 60Hz. Common mode range for patient cable input $\geq 10V$ peak with respect to isolated ground.
MONITOR DISPLAY SIZE SWEEP SPEED	102mm (4in) wide x 76mm (3in) tall, non-fade. 25mm/s
FREQUENCY RESPONSE ECG Leads: Paddles:	Non-diagnostic. 1.0 to 40Hz (-3dB) 2.2 to 20Hz (-3dB)
ECG SIZE HEART RATE METER	Adjusts amplitude of ECG trace on monitor and strip chart recorder. Three-digit readout displays rates from 20 to 300bpm. Heart rates outside this range do not yield valid systole tones or heart rate display.
HEART RATE ALARM	User-selectable alarm limits. Three high/low settings: 150/40, 120/60, 160/90. Other limit options available through the Setup Menu.
1 mV Cal	Momentary pushbutton on rear panel simulates a 1mV signal pulse to the ECG input.
ECG OUTPUT	1V/mV.
<b>Defibrillator</b>	
ENERGY SELECT External Paddles: Internal Paddles:	1, 2, 3, 4, 5, 6, 7, 8, 9, 10, 20, 30, 50, 100, 200, 300, 360J 1, 2, 3, 4, 5, 6, 7, 8, 9, 10, 20, 30, 50J
CHARGE CONTROLS	Independent momentary pushbutton controls on front panel and APEX paddle.
PADDLE CORD LENGTH CHARGE INDICATORS	3m (10ft) Flashing lamps on paddle and front panel pushbutton along with increasing stored energy display on monitor indicate charge in progress. Upon full charge, energy available is displayed and charge completed tone sounds.

\*All specifications at 20°C unless otherwise stated. Specifications subject to change without notice.

**Table 1-1 LIFEPAK 9 defibrillator/monitor Specifications\* (cont.)**

**Defibrillator (cont.)**

<b>CHARGE TIME</b>	Charge to 360J in less than 10s with a fully-charged battery.
<b>SYNC</b>	Synchronizes defibrillator pulse to patient-generated QRS complex.
<b>SYNC INDICATOR</b>	Inverted triangle marker on displayed ECG waveform identifies synchronizer trigger point with respect to patient's QRS complex.
<b>DEFIBRILLATOR ENERGY ACCURACY</b>	± 15% at 50Ω ± 30% over the range of 25 to 100Ω
<b>DEFIBRILLATOR WAVEFORM</b>	5ms monophasic pulse (Edmark)



**Thermal Array Recorder**

<b>PAPER</b>	
Size:	50mm wide x 30m (100ft)
Speed:	25mm/s
<b>DELAY</b>	ECG prints 8 seconds after first appearing on the monitor.
<b>FREQUENCY RESPONSE</b>	Non-diagnostic (diagnostic available via Setup Menu).
ECG Leads (non-diagnostic):	1.0 to 40Hz (-3dB).
ECG Leads (diagnostic):	0.05 to 100Hz (-3dB).
Paddles:	2.2 to 20Hz (-3dB).
<b>ANNOTATION</b>	Time, date, ECG lead, ECG gain, heart rate, defibrillation parameters, test load discharges.
<b>CODE SUMMARY Record</b>	Critical Event Digitally stored record of ECG and device parameters.

\*All specifications at 20°C unless otherwise stated. Specifications subject to change without notice.

Table 1-1 LIFEPAK 9 defibrillator/monitor Specifications\* (cont.)

<b>General</b>			
AC INPUT OPTIONS	120 or 240Vac nominal line voltage without adjustment. 50 or 60Hz with adjustment in Setup Menu.		
BATTERY TYPE	Sealed lead-acid, 16Vdc nominal, 3Ahr.		
BATTERY CAPACITY	A new, fully-charged battery will provide one of the following prior to shutdown:		
		<u>Typical</u>	<u>Minimum</u>
	Number of 360J discharges:	75	40
	Minutes of monitoring:	90	70
LOW BATTERY INDICATOR	Advises operator to connect ac power. Battery capacities before and after warning ( <b>LOW BATTERY-CONNECT AC POWER</b> ) for a new, fully charged battery are:		
		<u>Typical</u>	<u>Minimum</u>
	Number of 360J discharges before warning:	50	20
	Number of 360J discharges after warning:	25	5
BATTERY CHARGE INDICATOR	Indicator <b>BATT CHRG</b> illuminates when battery is charging.		
BATTERY CHARGE TIME	24hrs to full capacity.		
SERVICE INDICATOR	Message <b>SERVICE</b> indicates self-diagnostic routines have detected improper operation requiring service attention.		
POWER CONSUMPTION	160W maximum while monitoring with recorder on and defibrillator charging.		
SIZE			
Height:	35.2cm (13.9in)		
Width:	29.7cm (11.7in)		
Depth:	31.0cm (12.2in)		
Weight:	12.7kg (28lbs)		
POWER CORD LENGTH	3m (10ft)		
STANDARD PADDLE ELECTRODE AREA	82cm <sup>2</sup>		
<b>Environmental</b>			
ATMOSPHERIC PRESSURE	797 to 500mm Hg (-570 to 11,000ft).		
RELATIVE HUMIDITY	0 to 95% (non-condensing) at 0 to 34°C (32 to 94°F).		
	0 to 80% (non-condensing) at 35 to 45°C (95 to 113°F).		
TEMPERATURE RANGE	0 to 45°C (32 to 113°F) operating.		
	-30 to 65°C (-22 to 149°F) storage.		

\*All specifications at 20°C unless otherwise stated. Specifications subject to change without notice.

## Functional Description

The overall function of the LIFEPAK 9 defibrillator/monitor is shown in Figure 1-2. The defibrillator/monitor includes six mechanical assemblies (Keypad, Rear Panel Membrane Switch, Strip Chart Recorder, Transfer Relay, Paddles, and Battery Pack) and five Printed Circuit Board (PCB) assemblies (Power Supply, Power Conversion, Interconnect, Main, and Display).

The Keypad and Rear Panel Membrane Switch Assemblies receive operator input. The Strip Chart Recorder Assembly provides printed output. The Transfer Relay and Paddle Assemblies help deliver defibrillator pulses. The Battery Pack provides temporary backup power.

The Power Supply PCB functions over the full range of input voltages from 90Vac to 270Vac at 50Hz or 60Hz without input line voltage selection. The Power Supply PCB converts the ac line power to the nominal +18.8Vdc supplied to the Power Conversion PCB.

The Power Conversion PCB performs a variety of power-handling functions: power on/off switching, generation of additional power supply voltages, defibrillation charging, and stored energy transfer. A test load circuit is also present on the Power Conversion PCB.

The Interconnect PCB provides the electrical connection between the Main PCB and the Power Conversion PCB. It also contains circuitry to produce the audible tones and to drive the front panel LEDs.

The Main PCB has three major sections of circuitry: the Preamp, the System Controller, and the Display/Recorder Interface. The Preamp receives input from both the 3-lead patient cable and QUIK-LOOK paddles inputs. The System Controller directs the overall operation of the other circuits. QRS detection, rate calculation and alarms, and synchronous cardioversion are all implemented in the System Controller software. The current state of the System microprocessor and the ECG data are transmitted from the System microprocessor to the Display/Recorder microprocessor, allowing the Display/Recorder microprocessor to select and format the appropriate CRT messages and recorder annotations.

The Display PCB/CRT Assembly contains a Monitor PCB that drives the 5-inch diagonal Cathode Ray Tube (CRT). It uses electromagnetic beam deflection and incorporates vertical and horizontal deflection circuitry to produce a raster scan.

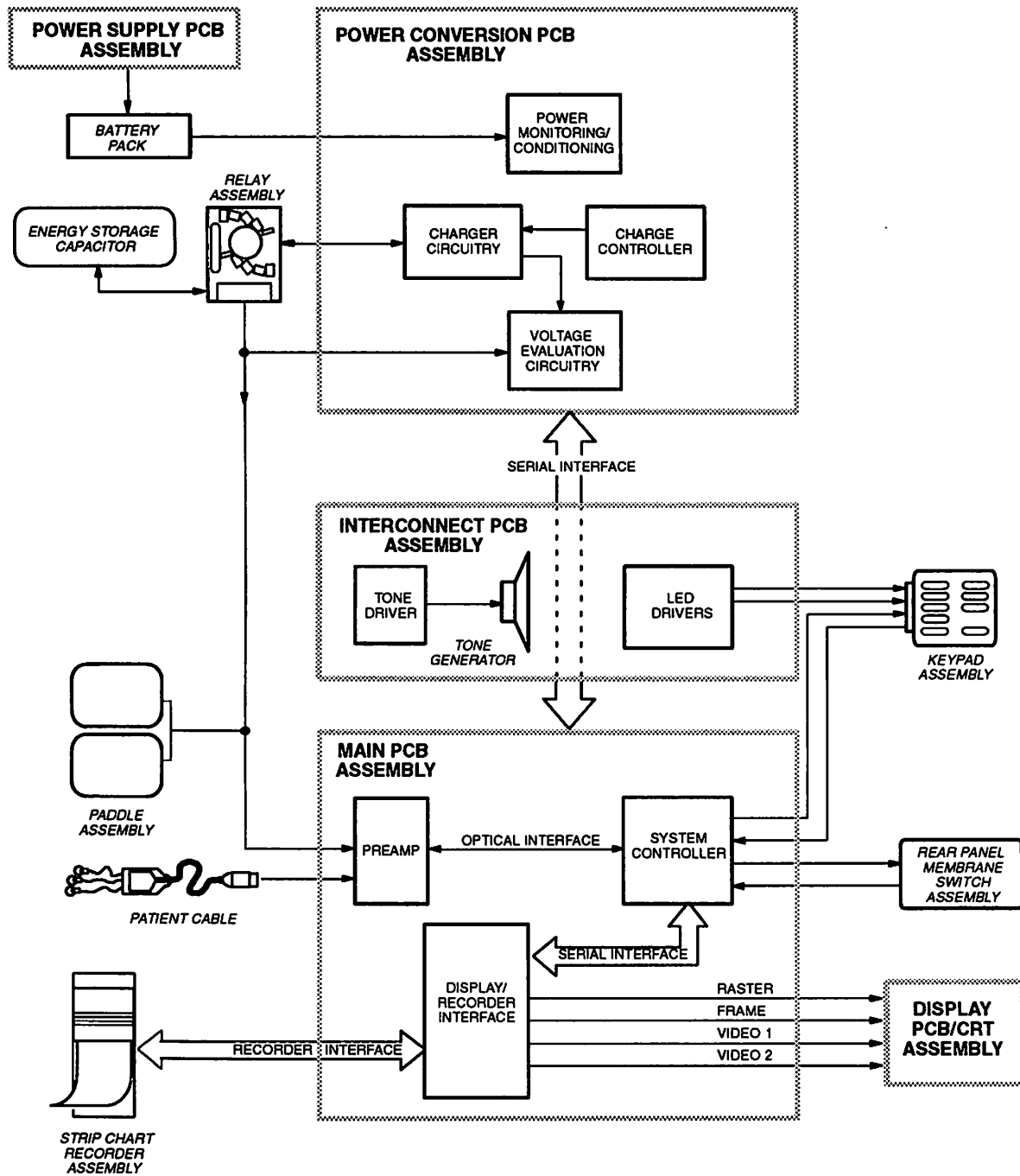


Figure 1-2 LIFEPAK 9 defibrillator/monitor Functional Block Diagram

---

## Theory of Operation

This section contains detailed circuit descriptions of the Power Supply PCB, Power Conversion PCB, Interconnect PCB, Main PCB, and Display PCB/CRT Assemblies. Refer to schematic diagrams of these electrical circuits in Section 5 while reading the circuit descriptions. Information about selected integrated circuits (indicated by a \* on the schematic) is provided in Section 6.

### Power Supply PCB Assembly (803726)

The Power Supply PCB converts input ac voltage to a nominal dc voltage for the Power Conversion PCB and for charging the battery.

#### Power-On

When ac current flows through J1, it is conditioned by RT1, L1, C2, C3, and CR1. Resistor divider R1, R3, and R4 in series with parallel resistors R11 and R12 turn on Q1. Current builds in T1 primary windings (pins 4 and 6) and is coupled with pins 1 and 2. Capacitor C6 couples the current build-up into Q1, causing saturation.

Increasing current through the T1 primary produces voltage on the base of Q2 and a voltage drop across parallel resistors R11 and R12. Q2 activation overrides Q1 and terminates the primary current. Transformer T2 sustains base drive current to Q2.

#### Regulation

When battery voltage exceeds the voltage threshold set by VR1, Q4 turns on and couples the voltage from T2 pins 4 and 5 to T2 pins 2 and 7. When current subsides to proper levels, Q4 turns off, providing current feedback for regulation.

#### Overvoltage Protection

If the regulation circuit fails, Silicon Controlled Rectifier (SCR) CR12, together with CR13, R17, and R18, protects the load from damage. Diode CR13 sets a voltage threshold which, when exceeded, triggers SCR CR12 to short the Power Supply PCB circuit output. Removing ac power resets the protection circuit.

#### Output Isolation

Diode CR11 isolates the Power Supply PCB output from the filter network to protect it from the battery voltage when ac power is removed. This is necessary because the battery is connected in parallel with the Power Supply PCB.

#### Battery

The 16Vdc, lead-acid battery is wired directly to the Power Supply PCB output. The battery receives a constant charging current whenever the instrument is connected to ac power and the rear panel mains power switch is on. As the battery approaches full charge, the supply operates in constant voltage mode. Current limiting sets the maximum charge current available to

the battery at approximately +4.5A. This limit is implemented when the Power Supply PCB sources current into a dead short, a requirement when charging a severely depleted battery.

#### BATT CHRG Indicator

A battery-charging LED signal illuminates the front panel BATT CHRG indicator whenever the ac power is connected to the instrument and the rear panel mains power switch is on. An interlock in the battery harness prevents the indicator from lighting if the battery is not installed.

#### Power Conversion PCB Assembly (803724)

The Power Conversion PCB contains circuitry for power on/off switching, additional voltage generation and monitoring, energy storage capacitor charging, and defibrillation energy transfer. Refer to Figure 1-3, page 1-10.

#### Power Control

The Power Control circuit regulates battery voltage for the circuits which control instrument operation. The circuits directly affected by the Power Control circuit are: Switching Power Supply, Logic Power Monitor, External Control Input, Low Energy Charge Rate, and Energy Storage Capacitor Charger circuits.

The Front Panel ON momentary pushbutton provides the start-up signal for the Power Control circuit. When the power switch is first pressed (turning power on), V BATT passes to the gate of Q11, causing Q11 to conduct, which in turn causes Q10 to conduct. A portion of V BATT is held on the gate of Q11 by R52, which keeps Q10 conducting. During this time the PWR SW MONITOR line is low and the Power Control circuit provides the SWBATT voltage for the rest of the Power Conversion PCB Assembly circuits.

When the power switch is pressed a second time (turning power off), V BATT is divided by R108 and R109, forward-biasing CR44 and switching the PWR SW MONITOR line high. The System microprocessor reads the low-to-high transition and activates the Logic Power Monitor circuit, disabling the Power Control circuit. The functional integrity of the Power Control circuit may be confirmed by monitoring two pins on the test connector: R60 (connects to the gate of Q10) and R57 (connects to the gate of Q11).

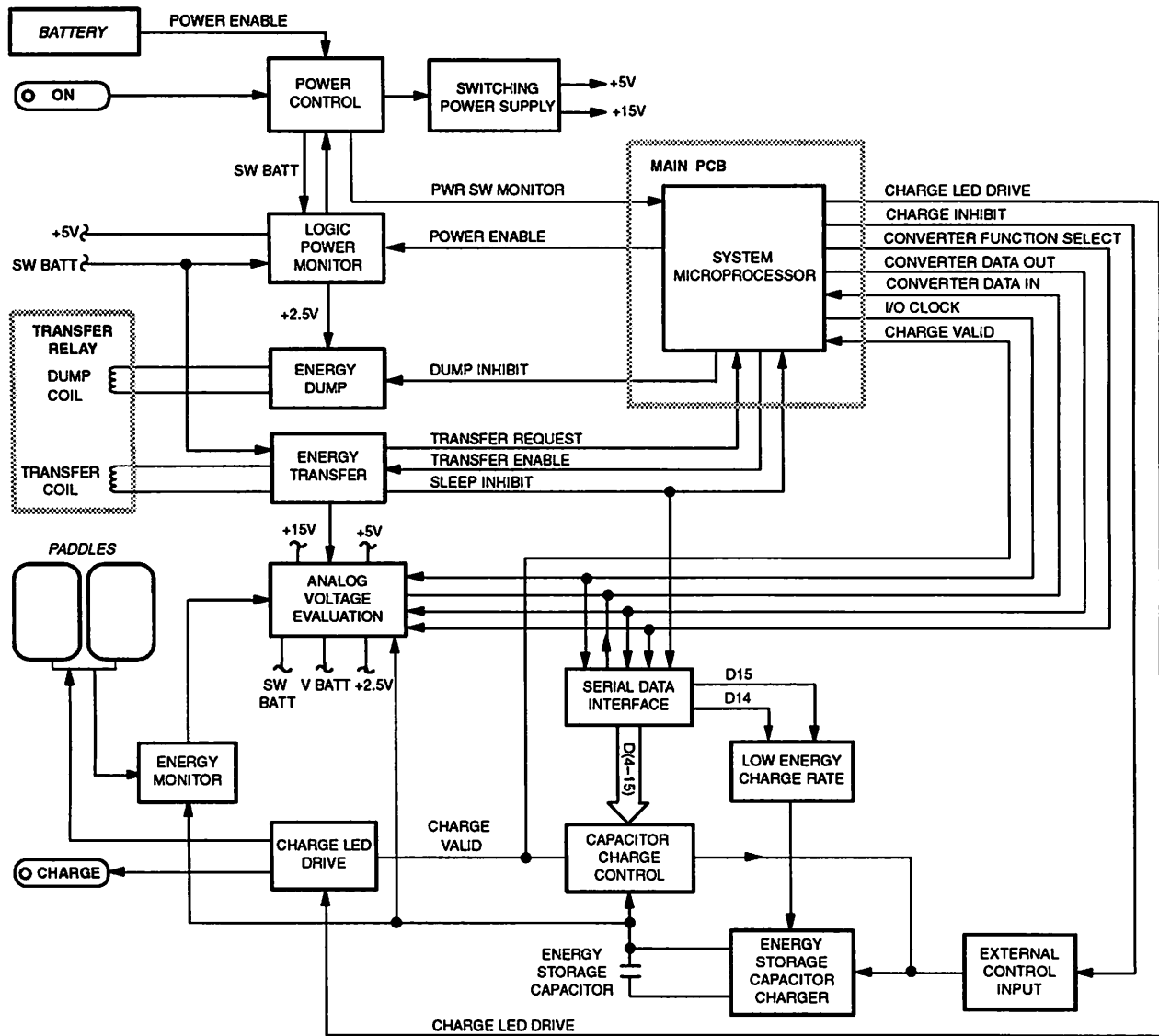


Figure 1-3 Power Conversion PCB Block Diagram

Logic Power Monitor

The Logic Power Monitor checks the logic supply voltage. If the logic voltage is above or below normal limits, it deactivates Q11 and disables the Power Control circuit. Comparator U5 functions as a window detector for high voltages (U5A) and low voltages (U5B). The comparator reference voltages are set by Diode IC U4 at +2.5V. The output of the Power Control circuit, SWBATT, generates the operating voltage for U5, U4, and the Switching Power Supply.

The System microprocessor shuts down the instrument by sending a low signal to the POWER ENABLE line. This switches the open collector output



of USB to ground which turns off Q11, disabling the Power Control circuit. Electrical isolation is provided by CR24 and R39.

A time delay function in the Logic Power Monitor circuit prevents the Power Control circuit from shutting down while operating voltages are still rising during initial power-on. Capacitor C26 accomplishes this for the high-limit detector (U5A) and C18 for the low-limit detector (U5B).

The low- and high-limit detector inputs to the test connector are used to check circuit performance by serving as test points to measure voltage. Voltage measurements check the accuracy of voltage dividers R41, R42, R43, and R56 (relative to the +5V supply).

#### Switching Power Supply

The Switching Power Supply uses a pulse-width regulator (U3) and a flyback-coupled inductor (T2) to produce the +5V to +15V supply voltages used by the other circuits.

The pulse-width regulator U3 contains an oscillator, reference voltages, an error amplifier, and drive circuitry for Q12. Oscillation frequency is set at 90Hz by R30 and C12. The +15V output feedback at U3 pin 2 determines the outgoing pulse-width. The pulse output at U3 pin 6 provides a constant frequency pulse by driving an N-channel FET (Q12) and dumping the V BATT voltage into the primary of T2. Two diodes, CR28 and CR29, protect Q12 from high voltages caused by leakage inductance from the primary.

#### External Control Input

The Energy Storage Capacitor Charger circuit is externally controlled by the N-channel MOSFET, Q9. Two resistors (R58 and R59) provide forward-biasing for Q9 whenever power is applied to the instrument. The System microprocessor on the Main PCB initiates a charge cycle for the energy storage capacitor by setting the CHARGE INHIBIT line at low voltage, turning Q9 off. The inverting input of U2A rises to the required +5V minimum.

#### Energy Storage Capacitor Charger

The Energy Storage Capacitor Charger circuit uses a flyback transformer to charge the energy storage capacitor through the Transfer Relay. The core of the circuit consists of the following components: T1, U2A and U2B, Q1, Q2, Q5-Q7, and C17.

Amplitude comparators U2A and U2B determine the drive pulse for the primary of T1. The input to the energy storage capacitor at U2A pin 2 is controlled by the External Control, Low Energy Charge Rate, and Capacitor Charge Control circuits. If any of these incoming signals fall below the +2.5V reference at U2A pin 3, the output switches high, inhibiting the drive to the primary of T1.

Once a charge cycle initiates at U2A pin 2, the active low output simultaneously performs two separate functions: transformer driver Q5 conducts, and Q7 shuts off. Timing for the transformer drive pulse-width is provided by Q7, U2B, C17, and R23. While Q7 conducts, the voltage across C17 is zero. When Q7 shuts off, the voltage at SWBATT starts charging C17. When the voltage at C17 exceeds +2.5V, the output of U2B switches low, forcing U2A output high and preventing current flow to the primary of T1.

The power circuit to the primary of T1 consists of two stages: Q5 and Q6 function as push-pull drivers, and Q1 and Q2 provide improved current handling for the drive pulse.

The secondary winding of T1 supplies the energy stored on the energy storage capacitor for defibrillation. The output is therefore subject to potentials of up to +4.5kV under normal operating conditions. Capacitor C1 limits the single pulse voltage rise to about +1.5kV, providing circuit-response time for control of the output voltage.

#### Low Energy Charge Rate

This circuit is centered around op amp U17A and is active only during low battery voltage levels, or when an energy level below 30J is selected. When a low battery voltage is detected, the Low Energy Charge Rate circuit slows the charge rate for the energy storage capacitor, thus reducing the amount of power required for charging. Similarly, the charge rate is slowed when a low charge energy setting is selected, thereby making sure the energy storage capacitor will not charge too quickly for the Analog Voltage Evaluation circuit to detect the energy level.

A signal from the System microprocessor at the energy request register, U20, determines the output of U17B. When an energy level of less than 30J is selected, low signals are applied to the inputs of U15D from U20. The U15D output then switches low, forcing CR45 to reverse-bias. This pulls the noninverting input of U17A to +5V, changing the output of U17A.

The signal from U17A controls the charge timing circuit (U2B, C17, and R23) and, in turn, the output of U2A. During normal charging, the effect of this signal is blocked by CR46. When U17A pin 1 is driven high, additional current is supplied to C17. This reduces the on-time of U2A which reduces current to the primary circuit and slows the rate of charge of the energy storage capacitor. This reduces the power consumption of the Energy Storage Capacitor Charger to less than half of normal. At 360J, the charge time is increased to 30 seconds.

The instrument can operate with low battery voltage if the power required for charging the energy storage capacitor is reduced. Op amp U17A detects low battery levels by monitoring the SWBATT voltage at the inverting input and

comparing it with the +2.5V at the noninverting input. When the threshold limit set on the noninverting input of U17A exceeds the SWBATT voltage on the inverting input, it indicates a failing battery. The output of U17A then functions as described in the previous paragraph.

### Capacitor Charge Control

The Capacitor Charge Control circuit controls the Energy Storage Capacitor Charger. It achieves and maintains a selected voltage on the energy storage capacitor and reports the capacitor voltage status to the System microprocessor. The main circuit components consist of op amp U17B and comparators U8A, U8B, and U8C.

Op amp U17B sets and maintains the selected voltage to the energy storage capacitor by controlling an inhibit signal to pin 2 of U2A. When a selected voltage is achieved, U17B shuts down U2A which disables the Energy Storage Capacitor Charger.

To set the gain for a particular charge voltage, digital-to-analog (D/A) converter U18 is connected between the inverting input and the output of U17B. The output of the D/A converter is controlled by selection of a 12-bit word by the System microprocessor. Resistors R2 and R4 function as voltage dividers for the energy storage capacitor output voltage. When this divided voltage is applied to the noninverting input of U17B, the gain of U17B rises accordingly.

Comparator U8C provides switching for the Energy Storage Capacitor Charger in response to input from U17B. When the output of U17B rises above +2.5V, U8C switches low. This low inhibit signal switches the output of U2A high, shutting down the Energy Storage Capacitor Charger.

Comparators evaluate the charge stored on the energy storage capacitor with respect to the defibrillation energy selected. U8B detects values greater than the minimum required for in-tolerance energy; U8A detects values less than the maximum allowed for the same energy setting. The outputs from U8A and U8B form the CHARGE VALID signal, indicating valid energy charge levels. This signal informs the System microprocessor about the status of the selected charge energy.

### Energy Transfer

The Energy Transfer circuit transfers the energy stored in the energy storage capacitor out through the paddles. The main circuit components are U6, Q4, C9, and CR4.

When the sternum and apex pushbuttons on the paddles are pressed, the Sternum Transfer and Apex Transfer lines at J17 produce the Transfer Request signal from the output of U15A which is sent to the System microprocessor. If all energy transfer parameters are correct, the System microprocessor returns a Transfer Enable signal through U11A and U14C.

The Transfer Enable signal enables and maintains a constant current to the Transfer Relay drive. The SWBATT voltage is stored in C9, enabling energy transfer to occur with minimum battery voltage dissipation. Transistor Q4 and SCR CR4 control this voltage and direct it to the Transfer Relay. To enable the relay drive, the signal from U14C turns on CR4. The signal from U11A forces U6A low, causing Q4 to conduct. With both CR4 and Q4 conducting, current starts to flow through R62. To maintain a constant current to the Transfer Relay when current through R62 increases, the noninverting input of U6A goes higher than the reference voltage at the inverting input and the output switches high. This turns off Q4, causing the current to decrease through R62 and switching U6A output low.

The high noise levels involved in the transfer of stored defibrillation energy can jeopardize the function of many types of logic signals, particularly if any are in transition from one state to another. To overcome this effect, the System and Display/Recorder microprocessors and other high speed logic components are rendered inactive during transfer. To accomplish this, U6B discharges C35 at the input of comparator U8D and holds U8D low during the time that the Transfer Relay coil is energized. The output of the U8D remains low for an additional period to allow the Transfer Relay to reopen and any stray current to dissipate. This signal, Sleep Inhibit, is used as a logic activity enable.

Sleep Inhibit also clears the shift registers, U19 and U20. This sets all inputs to U17B at 0V, which inhibits the drive to the Energy Storage Capacitor Charger. Inadvertent deactivation of the charge inhibit will then cause no discharge of stored energy from the energy storage capacitor.

## Energy Dump

The Energy Dump circuit provides a safe current path for unused energy stored in the energy storage capacitor. If the paddles are charged but not discharged within one minute, the Energy Dump circuit is activated.

The internal dissipation of stored energy is accomplished with the dump relay and a power resistor located within the Transfer Relay Assembly. The dump relay is held in the normally closed condition by a permanent magnet. When a charge is initiated, the contact opens to prevent the stored energy from draining.

The System microprocessor controls Q3, preventing the paddles from being charged for longer than one minute. Prior to any charge activity, the System microprocessor holds the Dump Inhibit line low, keeping Q3 turned off and the dump relay closed. During charging, the Dump Inhibit line is switched high, turning on Q3 and opening the dump relay. If the one-minute charge time-out expires or a different energy setting is chosen, the System microprocessor turns Q3 off again to close the dump relay and dissipate the stored energy.

## Energy Monitor

The Energy Monitor circuit confirms the level of energy that is discharged into the internal test load. When an energy transfer is performed as a test, this circuit senses the energy delivered to the test load and informs the System microprocessor. The System microprocessor then displays the information (e.g., **200J DELIVERED**).

The value of the defibrillation pulse is acquired by monitoring the delivered energy with a current transformer, T3. A proportional current is generated in the secondary with each transfer pulse. A rectifier bridge, CR8 through CR10, delivers the secondary current to C10. The voltage is indexed in the System microprocessor to a specific delivered energy.

Capacitor C10 must start each transfer cycle with 0V for accurate evaluation of the delivery. FET Q8 is in parallel with C10 and resets C10 before each charge energy pulse. The gate of Q8 is driven by the inverted Charge Inhibit signal. The FET Q8 shorts C10 when the charge is enabled which makes sure that each time the instrument is ready to deliver energy, the Energy Monitor circuit determines the correct energy level. Op amp U1A functions as a noninverting buffer, providing high-impedance isolation from the rest of the signal processing circuitry.

## Serial Data Interface

The Serial Data Interface consists of four lines; Converter Data In and Converter Data Out allow communication while Converter Function Select and I/O Clock control data flow. The Analog Voltage Evaluation circuit and the D/A converter U18, used with the Capacitor Charge Control circuit, share this common set of serial lines for communication with the System microprocessor.

A low on the Converter Function Select line at connector P14 pin 7A enables the Analog Voltage Evaluation circuit for data transfer. The data flow rate is set by I/O Clock at P14 pin 6A. A high on the Converter Function Select line at P14 enables 8-bit shift registers U19 and U20, allowing I/O Clock access to the register clock inputs. Information on the Converter Data Out line is stored in the low-order location, and all other bits are advanced one position during the positive-going transitions of I/O Clock. At the same time, U12A through U12C route the output data on the Converter Data In line. A logic high at U11C pin 8 following a byte transfer indicates a communication failure.

## Analog Voltage Evaluation

The Analog Voltage Evaluation circuit monitors operating voltages on the Power Conversion PCB. An A/D converter, U9, converts these voltages to digital code for evaluation for correct tolerances by the System microprocessor.

## Charge LED Drive

The Charge LED Drive signal from the System microprocessor controls Q14 when the energy storage capacitor is charging. Transistor Q14 drives the front panel CHARGE LED and the paddle CHARGE LED. Resistor R128 on the drain of Q14 limits the current to the Paddle LED. The gate of Q13 is connected to the Charge Valid signal. When the voltage for the selected energy level has been reached, Q13 conducts. Transistor Q14 then clamps the charge LEDs on continuously.

## Interconnect PCB Assembly (803761)

The Interconnect PCB provides electrical connection between the Main PCB and the Power Conversion PCB. It also drives the front panel LEDs and generates the audible tones.

The LED drive circuitry consists of Q4, Q5, Q13, R14, R15, and R11. Static protection is provided by R9, R21, R22, C6 through C8, and CR1 through CR11.

The Main PCB System microprocessor selects 1 of 8 volume levels by writing the appropriate binary number (000 for the loudest and 111 for the softest) on line VOL1, VOL2, and VOL3. These lines are routed to 3-to-8 decoder U1 on the Interconnect PCB. Static protection is provided by R1 through R4, C1 through C3, and C5.

The decoder U1 sets the voltage required for the volume level selected by the System microprocessor. The decoder output turns on one of the transistors (Q1 through Q3 or Q7 through Q10) which puts the corresponding resistor in series with R8. The center tap of the resistor divider is routed to the input of either U2A or U2B as determined by Q11, Q12, and Q6. The output of U2A or U2B applies the voltage to the piezoelectric transducer, X1.

The free-running oscillator in the System microprocessor generates the desired tone frequency. The oscillator generates a square wave, Audio Drive, which is routed to the gate of Q11. If the voltage at the gate of Q11 is low, Q12 conducts, grounding U2A pin 3. Transistor Q6 then shuts off, applying the selected voltage to U2B pin 5. If the voltage at the gate of Q11 is high, Q11 switches on and Q12 switches off, applying the selected voltage to U2A pin 3. Transistor Q6 then turns on, grounding U2B pin 5. Therefore, the frequency of the oscillator controls transistors Q11, Q12, and Q6, which drive the transducer. Op amps U2A and U2B provide buffering and high current drive to X1.

## Main PCB Assembly (803715)

The Main PCB Assembly, illustrated in Figure 1-4, consists of three major circuits: the Preamp, the System Controller, and the Display/Recorder Interface. The Preamp circuitry converts the ECG from the patient cable to sampled ECG. The converted ECG signal is optically connected to the System microprocessor which performs the initial ECG signal processing. The System microprocessor is central to the System Controller circuitry. The System Controller provides the interface between the operator inputs and the instrument functions. The Display/Recorder Interface controls the CRT and recorder displays according to the information supplied by the System microprocessor.

The three major circuits control the functions listed in Table 1-2. Each circuit is described in the following paragraphs.

**Table 1-2 Main PCB Functional Circuits**

Preamp	System Controller	Display/Recorder Interface
Isolated Power Supply	Front and Rear Panel Controls Interface	Display/Recorder Controller
Front-End Protection	Audio Alarms	System Clock
Lead Select	Charge Control	Address Decode
Optical Interface	I/O Protection	Display Gate Array
Instruction Decoding		Video RAM
Instrumentation Amplifier		Font EPROM
Filtering		Program EPROM
DC Restore		Program RAM
Echo		Recorder Power
		Motor Speed Control
		Printhead Control
		Printhead Resistance Evaluation

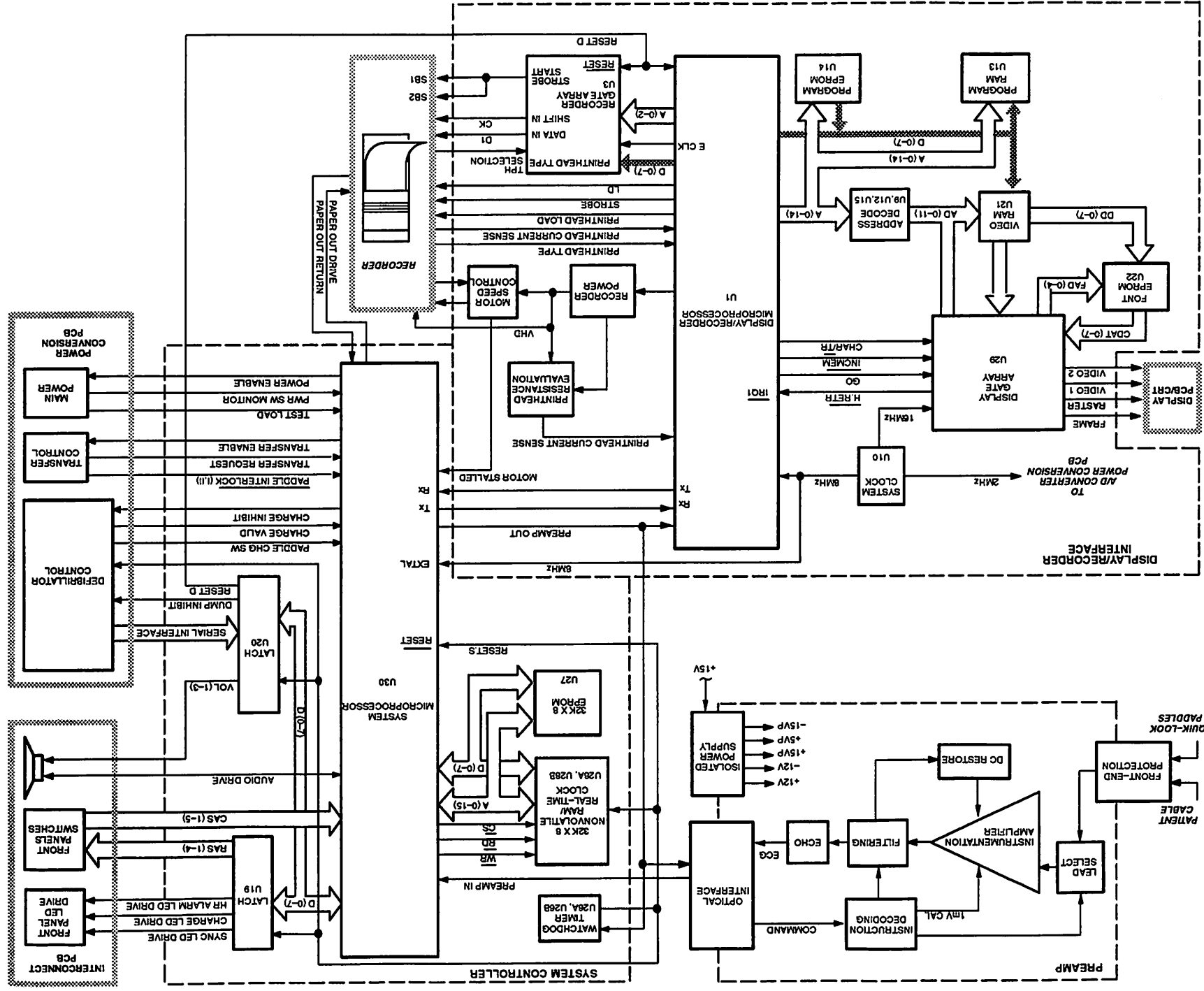


Figure 1-4 Main PCB Block Diagram



## Preamp

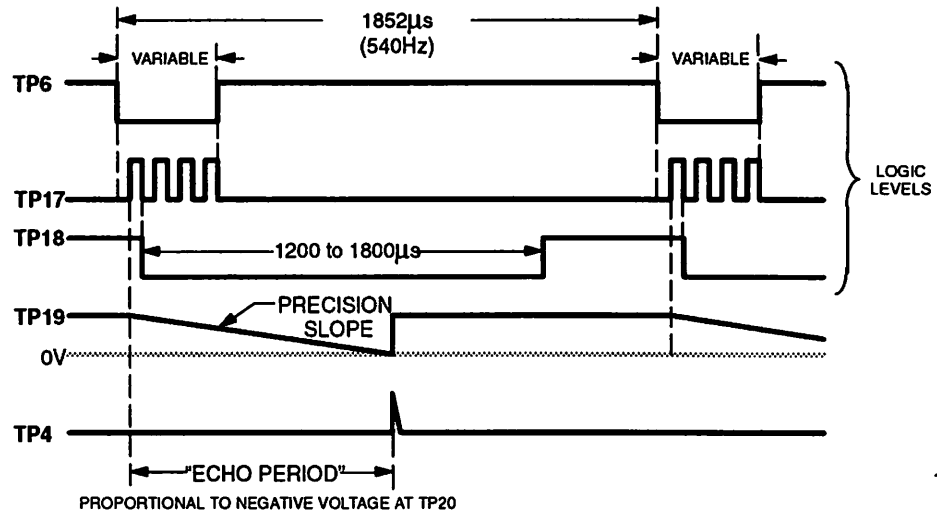
**Isolated Power Supply.** The Isolated Power Supply provides the isolated +15Vdc, +12Vdc, -15Vdc, +5Vdc, and -12Vdc supplies required by the Preamp circuitry. The drive for transformer T1 is generated by pulse-width modulator U5. Capacitor C12 and R28 set the frequency between 12kHz and 24kHz. The secondary of T1 is applied to full-wave bridge CR20. The positive half of the ac input waveforms are stored at C87, forming the isolated +15V supply. The negative ac waveforms are stored at C86, forming the isolated -15V supply. Regulators U38 and U39 isolate more sensitive circuitry from the heavier loads. Since the +5Vdc loads are synchronous and small, U37 doubles as a regulated supply and a reference source.

**Front-End Protection.** To protect against voltage surges, VSP1 through VSP3 limit the input current to 2mA. Isolation for the paddles input is provided by R131 and R132 which guard against excessive charge input to the Preamp. Diodes CR18, CR19, and CR28 clamp the differential paddle voltage when K1 is switched to the leads mode.

**Lead Select.** To select between paddles and the different patient leads, latch U33 is loaded with the decoded data from counter U32. Flip-flop U33 controls relay K1, U43A, and analog switches U42 and U41. To select between patient leads or paddles, U33 causes Q8 or Q9 to conduct, switching the state of K1 to the desired position. Patient leads are selected when Q8 conducts; paddles are selected when Q9 conducts. If patient leads are selected, analog switch U42 selects the lead (I,II,III, or STD) requested by the output of U33.

**Optical Interface.** Command pulses from the System microprocessor pass through the the optical interface to perform three different functions: synchronize the ECG conversion, select 1 of 5 patient cable leads, and induce a +1mV calibration signal. The System microprocessor uses an internal timer to transmit a pulse of variable duration (approximately 80ms to 1.2ms) and a fixed-frequency period (540Hz). The variable-duration pulse from the System microprocessor enables U4 to start counting, creating a 16kHz pulse train at U4 pin 4.

The System microprocessor controls the count of the pulse train by interrupting the output with a CLR signal as shown at TP6 in Figure 1-5. The 16kHz pulse drives the infrared-emitting diode in U7 providing pulse isolation. Comparator U34D performs waveform conditioning for the pulse train as it passes to the Instruction Decoding circuit, U32 and U33.



**Figure 1-5 Preamp Timing**

**Instruction Decoding.** The pulse train commands from the System microprocessor are coded by the number of pulses as listed in Table 1-3. The number of pulses represents a binary number which corresponds to a particular command function. Each set of pulses performs two tasks: application of a specific preamp setup, and initiation of ECG signal conversion to a digital equivalent. The rising edge of the first pulse is detected by U31A which responds by sending a pulse to U34A. This initiates the ECG conversion. Monostable multivibrator U31B detects the falling edge of the first pulse and clears U31A so that ECG conversion is not initiated with every pulse on the pulse train.

Flip-flop U36A and counter U32 form a five-stage counter that responds to the pulses from the pulse train (see TP17, Figure 1-5). The first rising edge of the pulse train causes the five-stage counter to load from the preset inputs (pins 6, 5, 3, and 4). Subsequent edges count up from the preset inputs. Because of the timing of RC network R101 and C74, U31B times out at about 1.5ms and sends a positive edge to U33, latching the decoded command signals. These command signals select between leads and paddles.

**Instrumentation Amplifier.** The typical ECG signal at U41 and U42 is 16mV p-p maximum and requires amplification for further signal processing. U44A and U44B together form a differential input amplifier with the gain set by RN2 pins 1 and 2, R144, and RN2 pins 3 and 4. Op amp U44D amplifies the differential signal and rejects the common-mode signal from U44A and U44B. This common-mode signal (primarily 60Hz) is generated from the outputs of U44A and U44B through voltage dividers R148 and R149. The common-mode signal is then inverted and amplified by U35D and passes through analog switch U41 and K1. Relay K1 routes the signal to the unused patient lead (LL) cancelling common-mode signals at the patient source.

Table 1-3 Preamp Pulse Widths

Pulses at TP17	Pulse Duration At TP6 (ms)	Result on Preamp Setup
1	64	Not used
2	128	Not used
3	192	Not used
4	256	Lead III
5	320	Lead II
6	384	Lead I
7	448	Std
8	512	Lead III + Cal
9	576	Lead II + Cal
10	640	Lead I + Cal
11	704	Std + Cal
12	768	Lead III + Leads Coil Drive and Switch Smooth
13	832	Lead II + Leads Coil Drive and Switch Smooth
14	896	Lead I + Leads Coil Drive and Switch Smooth
15	960	Std + Leads Coil Drive and Switch Smooth
16	1024	Lead III + Cal + Leads Coil Drive and Switch Smooth
17	1088	Lead II + Cal + Leads Coil Drive and Switch Smooth
18	1152	Lead I + Cal + Leads Coil Drive and Switch Smooth
19	1216	Std + Cal + Leads Coil Drive and Switch Smooth
20	1280	Lead III + Paddles Coil Drive and Switch Smooth
21	1344	Not used
22	1408	Not used

The +1mV calibration signal is created by an instruction from the System microprocessor which sets U33 pin 7 high. When U43A closes, a -5V offset signal is applied to U44A pin 2 and U44B pin 6. This adds a differential offset of approximately +1mV to the input without changing the gain of the input stages.

**Filtering.** Filtering provides a uniform signal bandwidth during normal operation. The preamp filtering is performed by two stages centered around op amps U44C, U45D, U45A, and U45B. In the first stage, U44C and U45D function as a high-pass filter for Preamp, DC Restore, and switch smoothing, blocking frequencies below 0.024Hz. In the second stage, low-pass filter U45A removes frequencies above 200Hz. U45B functions as a 540Hz notch filter.

**DC Restore.** The DC Restore circuit compensates for any unwanted dc offset originating from switch smoothing, defibrillation, or motion artifact.

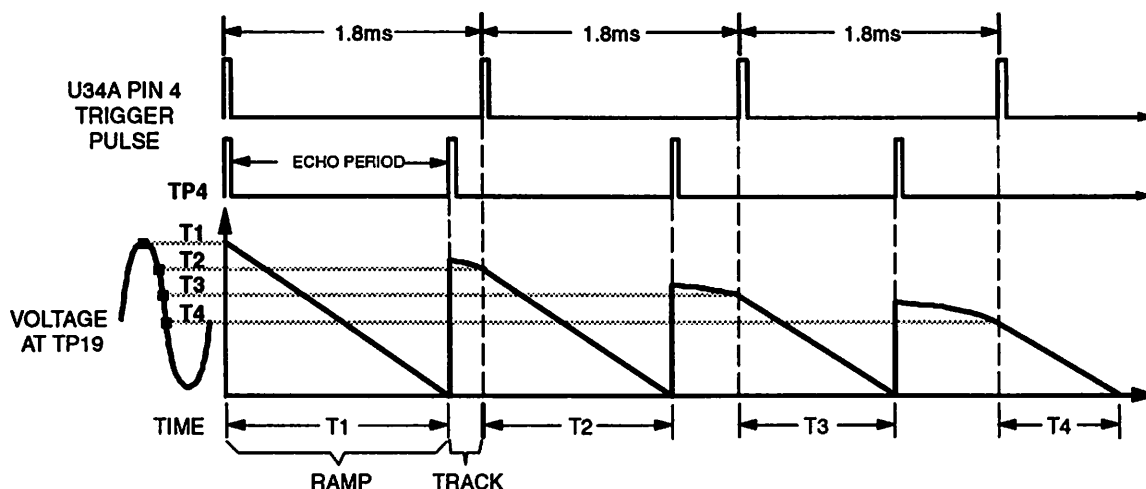
This preserves the dc offset level required by the Echo circuit. DC Restore controls any transient signals to prevent the high potential gain of the Instrumentation Amplifier from falsely amplifying the dc level input for conversion. Under normal operation, the A/D conversion dc level at TP19 is from +1V to +11V.

Switch smoothing is the process of limiting the response of the preamp to dc offset voltages when switching from one lead (I, II, III, or STD) to another. This function is initiated when the appropriate number of pulses (see Table 1-3, pulses 12 thru 20) turns on Q8 or Q9 and switches U42 to the selected lead. When Q8 switches on, C90 discharges from +12V, causing Q11 to conduct. Q11 changes the high-pass filter by switching R161 in parallel with R165. Because of R161, this filter limits the signal passband to above 40Hz.

Transient signals associated with defibrillation are sensed by op amp U45C. U45C functions as a window comparator and responds with a positive output when the voltage at its input exceeds  $\pm 2V$ . Resistors R172 and R147 apply a negative bias to the noninverting input of U45C; R171 and R143 apply a positive bias to the inverting input. C104 and R151 function as a low-pass filter to prevent very short spikes (such as an internal pacing spike) from inducing DC Restore. The output of U45C drives transistor Q10, routing the signal through high-pass filter U44C and U45D. Resistor R160, with U44C and U45D, limits the signal passband to 5Hz.

When **PADDLES** is selected, further passband limiting is required to eliminate motion artifact introduced by the paddles when used in the QUIK-LOOK mode. A command pulse selects paddles mode, (see Table 1-3, pulse 20), turning Q9 on. When Q9 conducts, flip-flop U36B is loaded so that the next clock pulse at pin 6 switches the Q output high. Analog switch U43B then closes, bringing R155 in parallel with R165 in the high-pass filter, and limiting the ECG signal passband to above 2Hz.

**Echo.** The ECG signal is converted to a pulse-delay period on command from the System microprocessor. The time from when the convert command from the System microprocessor is received until the "echo" pulse is sent back to the System microprocessor is proportional to a sample of the ECG signal (see Figure 1-6). When the echo pulse is sent back to the System microprocessor (across an opto-isolator), the System microprocessor converts the pulse-delay period to a number.



**Figure 1-6 Echo Period**

ECG conversion begins when the pulse train at the output of counter U4 passes to U32 pin 2. The rising edge of the first pulse clocks U31A, which sends a trigger pulse every 1.8ms to U34A. The ECG signal is offset to -6.3V at the output of U35A, providing a signal range of -1V to -11V for conversion.

The ECG signal from U35A passes to a track and ramp circuit consisting of U35B, U35C, Q7, and C76. This circuit controls the duration of the echo period. The track phase begins when Q7 conducts, which causes the ECG signal at U35B to charge sampling capacitor C76. The ramp phase starts when comparator U34A receives the trigger pulse (every 1.8ms), driving the output to -12V. This voltage passes to the gate of Q7 turning Q7 off. The +5V line and R122 provide a constant current source to the inverting input of U35C. When Q7 turns off, the constant current source causes a linear discharge from C76. This discharge produces a ramp output from U35C (see Figure 1-6).

While the track and ramp circuit is tracking, comparator U34A receives the trigger pulse from U31A. This drives the output of U34A to -12V, turns off Q6, and allows the +15V supply to charge C72 through voltage dividers R100 and R99. The output of comparator U34C controls the on-time of Q6, which discharges C72 through opto-isolator U6 and creates the echo signal.

The duration of the ramp output of the track and ramp circuit determines how long the output of U34C is low and sets the duration of the echo period. When the ramp output of U35C reaches 0V, the output of comparator U34B switches to -12V, presenting this voltage at the inverting input of U34C. This causes the output of U34C to switch to high impedance which turns on Q6 and allows the echo signal to be coupled through opto-isolator U6.

## System Controller

The System Controller circuit receives input signals from the front panel keypad and sends commands to the CRT, recorder, and defibrillation circuits. The central component of this circuit is System microprocessor U30, together with external RAM and ROM devices. The System microprocessor converts the ECG echo pulse widths to sample values for the CRT and recorder. These ECG samples are then sent to the Display/Recorder microprocessor for filtering and display on the CRT.

U30 communicates with the Display/Recorder microprocessor (U1) through two asynchronous serial transmit and receive lines at pins 12 and 13. In addition to the three 8-bit I/O ports contained in U30, 16 extra output lines are created by routing D0 through D7 in parallel out to octal latches U19 and U20.

The operating software for the System Controller is contained in U27, a 32k x 8 EPROM. Battery-backed RAM U28A provides data storage, including the calibration constants. DIP (Dual In-line Package) socket U28B contains the lithium energy cell and real-time clock information. Address decoding is performed by 3-to-8 decoder U25 using only the outputs at pins 12, 13, and 14.

Multi-vibrator U26 and flip-flop U16 form the watchdog circuit for the System microprocessor and the Display/Recorder microprocessor. The watchdog circuit monitors the 1.8ms preamp trigger pulse and resets both microprocessors if the pulse width is out of tolerance. An RC network consisting of R46 and C31 is used by U26 to detect a pulse width that is too short; R47 and C33 detect a pulse width that is too long.

Controller U46 monitors the +5V supply and causes a system reset as needed. This protects the RAM memory and prevents spurious microprocessor activity. If the controller detects that the +5V supply is out of tolerance, the output at NOT CEO switches high and causes Q5 to conduct, pulling the voltage at R45 low. This low logic level (through U23C, U18A, and U17A) goes to the  $\overline{\text{RESET}}$  lines for the System microprocessor and the Display/Recorder microprocessor.

**Front and Rear Panel Controls Interface.** Signals from the front and rear panels are distributed to the System microprocessor which determines what function(s) to activate. Input from the pushbuttons on the front and rear panels are arranged in a matrix of five columns (CAS 1 through 5) and three rows (RAS 1 through 3). The System microprocessor functions as a multiplexer, providing a high logic level for each row and sensing any closed column switch.

**Audio Alarms.** The System microprocessor switches the audio alarm on and off and controls the volume. A piezoelectric transducer on the Interconnect PCB produces an audible tone in response to input from the System

microprocessor. An internal oscillator in the System microprocessor provides four tone frequencies, including the key-click response when a pushbutton is pressed. Three output lines, VOL1 through VOL3, produce eight volume levels. The audio is silenced by turning off the System microprocessor internal oscillator.

**Charge Control.** The System microprocessor initiates and monitors charge requests to the D/A converter U18 on the Power Conversion PCB. The I/O Clock, Converter Function Select, Converter Data In, and Converter Data Out lines accomplish serial communication with the D/A converter. Pressing CHARGE on the keypad transmits the coded selected energy value from the System microprocessor to the Power Conversion PCB over the Converter Data Out line. Status information on the decoding process on the Power Conversion PCB is sent back to the System microprocessor over Converter Data In. The I/O Clock provides synchronous timing for serial communication.

Following the charge initiation, the System microprocessor performs a set of self-tests which are completed before the selected energy is available. If a self-test fails, the CRT displays the **SERVICE** indicator.

The energy stored in the energy storage capacitor is monitored through a 10-bit A/D converter (U9) located on the Power Conversion PCB. The A/D converter shares the four-line, serial-communication interface with the D/A converter. If the System microprocessor indicates that the energy stored is out of tolerance, an **ENERGY FAULT** message is displayed.

**I/O Protection.** Electrostatic discharge protection is provided by the resistors and capacitors on all the I/O lines that connect to the Main PCB. Additional protection is provided by 6.2V zener diodes, CR7 through CR9, on the Video 1, Video 2, and Raster lines directed to the Monitor PCB.

#### Display/Recorder Interface

**Display/Recorder Controller.** The central component of this circuit is the Display/Recorder microprocessor U1. It receives the digitized ECG signal data from the System microprocessor and controls the input of this data to the Display PCB Assembly CRT and the recorder. Because the CRT screen resolution is not as high as the recorder resolution, the Display/Recorder microprocessor compresses ECG data for the CRT display. The recorder receives all incoming ECG data samples. The Display/Recorder microprocessor also formats the ECG data for the CRT so waveforms are not displayed with gaps or overlapping segments.

ECG sample data is transmitted from the System microprocessor to the Display/Recorder microprocessor through the Tx serial communication line approximately every 1.8ms. Other data/command bytes from the System microprocessor are also transmitted to the Display/Recorder microprocessor

when they are required for a particular function. This data is transmitted in packets containing a header byte, two ECG sample bytes, and, if required, a data/command byte.

The first four I/O lines listed in Table 1-4 communicate with the Display Gate Array, U29, driving the input for the Display PCB. The other five I/O lines control the operation of the recorder.

**Table 1-4 Display/Recorder Microprocessor I/O Lines**

I/O Line	Signal	Direction
P(50)	<u>H.RETR</u>	In
P(52)	GO	Out
P(53)	<u>INCMEM</u>	Out
P(54)	<u>TR/CHAR</u>	Out
P(21)	STROBE	Out
P(60)	RECORDER POWER	Out
P(61)	PRINTHEAD CURRENT SENSE	In
P(66)	PRINTHEAD TYPE	In
P(67)	PRINTHEAD LOAD	Out

**System Clock.** Crystal-controlled multiple-output oscillator U10 provides a 16MHz square wave to the Display Gate Array. It also supplies 8MHz to both the System and Display/Recorder microprocessors (U30 and U1), and 2MHz to A/D converter U9 on the Power Conversion PCB.

**Address Decode.** Programmable logic array U9 controls the reading from and the writing to all external memory and the Recorder Gate Array, U3. U9 functions as an address decoder and is programmed to enable the appropriate devices when the Display/Recorder microprocessor addresses different areas in memory.

Buffers U11, U12, and U15 isolate the appropriate RAM/ROM memory devices from interaction with the Display/Recorder microprocessor. U11 buffers the data bus. Buffers U12 and U15 control interaction on the address bus between the Display/Recorder microprocessor, the Display Gate Array, and the RAM/ROM memory devices.

**Display Gate Array.** Display Gate Array U29 is a custom IC containing many blocks of standard OR and AND gate circuits (counters, multivibrators, flip-flops, etc.). A metalized layer added on top of the gate circuits connects only those circuits needed for a specific function: Monitor PCB sync timing, ECG memory addressing, ECG display trace generation, video intensity, and additional timing signal generation. Two different internal counters control



the timing of the Video RAM (U21) and Font EPROM (U22) addressing during CRT scan periods, and control the Video RAM addressing during CRT retrace periods.

The Display Gate Array uses an 18-bit counter to control the timing of the vertical and horizontal retrace on the CRT. The lower 8 bits correspond to 256 rows, and the upper 10 bits correspond to 768 columns (scan lines). When a count of 256 occurs, U29 initiates a vertical retrace. When a count of 196,608 (256 x 768) occurs, the gate array initiates the horizontal retrace.

Four separate memory loops for two separate trace generators in the Display Gate Array format the ECG signal in memory. Formatting occurs during horizontal retrace. An internal 11-bit counter addresses each memory loop. Each trace generator uses one memory loop for the high point of the scan and another memory loop for the low point of the scan. The trace appearing on the CRT screen is created by turning the video on at the screen location that corresponds to the low point, and turning the video off at the screen location that corresponds to the high point. This saves memory space in Video RAM U21 since the only data loaded in memory is the high point and the low point addresses for each scan.

Serial communication between the Display Gate Array and the Display/Recorder microprocessor is accomplished by the following control lines:  $\overline{\text{H.RETR}}$ ,  $\overline{\text{GO}}$ ,  $\overline{\text{INCMEM}}$ , and  $\overline{\text{TR/CHAR}}$ . These lines enable the Display Gate Array and the Display/Recorder microprocessor to coordinate the storage and retrieval of ECG and character data in the Video RAM during horizontal retrace. Figure 1-7 shows the control line timing sequence.

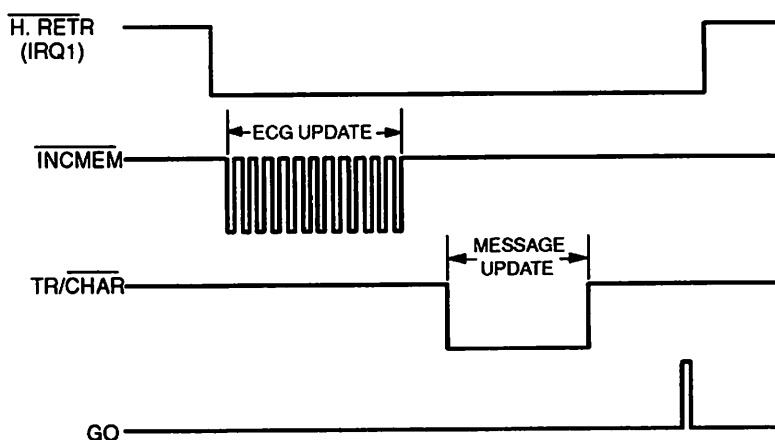
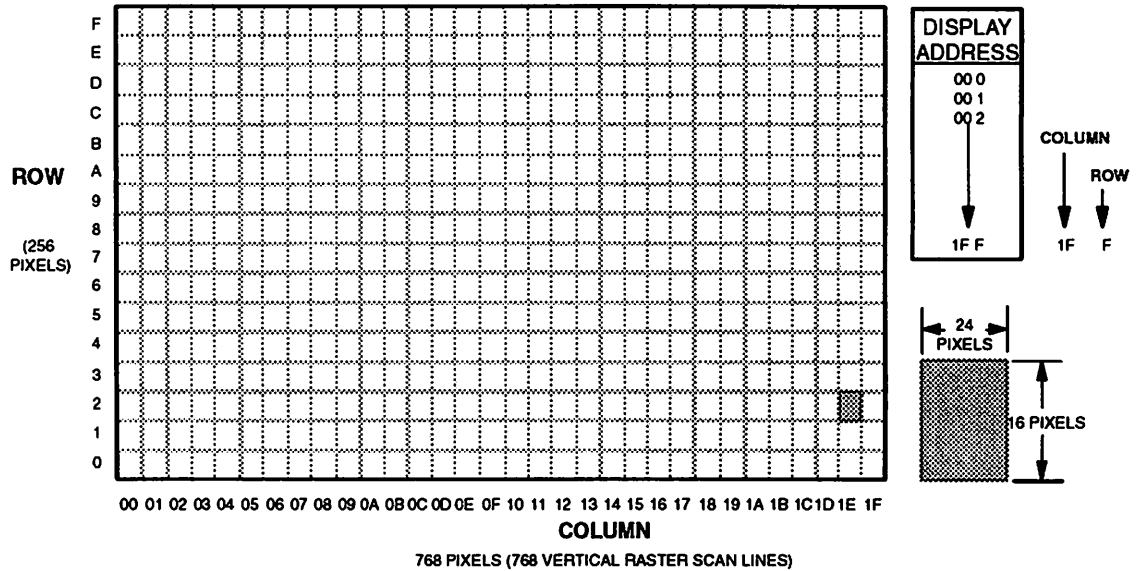


Figure 1-7 Control Line Timing

Data from the Display/Recorder microprocessor loads into the Video RAM memory during horizontal retrace. Six ECG samples update during horizontal retrace to smooth scrolling of the trace displayed on the CRT.

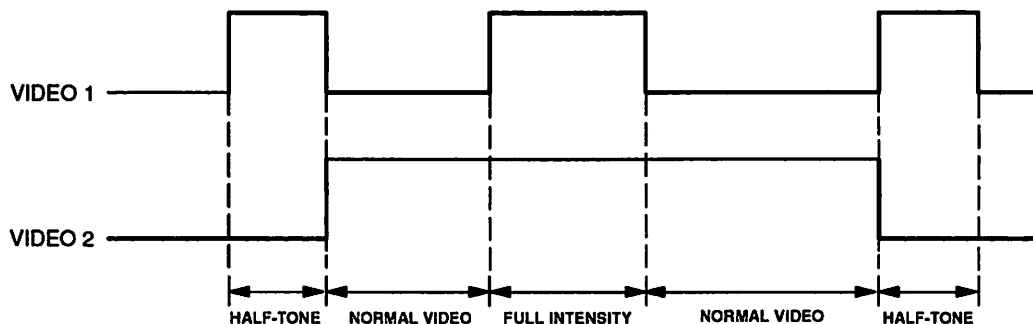
Coded character address data used by the Font EPROM also loads into Video RAM at this time.

ECG trace and messages display during raster scan. The Video RAM sends ECG data to the Display Gate Array through EDAT(0-7); character address information passes to the Font EPROM through DD(0-7). Character pattern data stored in the Font EPROM is addressed and routed to the Display Gate Array as CDAT(0-7). The Display Gate Array sends the character data out to the proper address on the Display PCB (see Figure 1-8).



**Figure 1-8 Character Cell Locations**

The Display Gate Array also functions as a video intensity circuit, producing four levels of brightness for the trace and characters. Two video outputs from the Display Gate Array, Video 1 and Video 2, generate the appropriate brightness level for the digitized display data by transmitting the data in a two digit code to the Video Signal Amplifier circuit on the Monitor PCB. This code determines if the addressed pixel will be at full intensity, normal video, half-tone, or off (see Figure 1-9). Half-tone is used only for the endpoints of the ECG waveform segments; full brightness is used only for the sync marks. The rest of the ECG waveform and all the characters are transmitted with normal brightness.



**Figure 1-9 Video Intensity**

Character dot information merges with trace information to create the video input signal. Messages have priority over waveforms when the two types of data are mapped to the same point on the CRT.

**Video RAM.** Trace and character data are stored in a 32k x 8 static RAM, U21. New ECG data is stored during the horizontal retrace and consists of twelve bytes. Horizontal retrace provides an interrupt to the Display/Recorder microprocessor which signals permission for a memory access. New data storage and memory address counter incrementing is controlled by the Display/Recorder microprocessor.

An additional 512 bytes are used for storage of the character address codes (similar to ASCII codes). The screen can be configured into a matrix of 16 x 32 character cells, with each cell accepting character information from the Font EPROM. The message content is updated as needed by the Display/Recorder microprocessor during horizontal retrace.

**Font EPROM.** A 32k x 8 EPROM, U22, contains character font patterns, with memory for 256 characters. Each character is 16 pixels high and 24 pixels wide to fit in the screen character cells (see Figure 1-8). The displayable character set includes single-sized numerals, punctuation, and uppercase letters in normal, inverse, and boldface video. Special characters and double-sized numerals are in normal video display.

**Program EPROM.** Another 32k x 8 EPROM, U14, contains the operating software for the Display/Recorder microprocessor. Included in the software is a list of codes representing all of the words and phrases used in the annotated recorder text.

**Program RAM.** The Program RAM U13 is used by the Display/Recorder microprocessor as a scratch-pad while performing program functions. Additionally, all CODE SUMMARY data and the Display/Recorder microprocessor bulletin board is stored in the Program RAM.

**Recorder Power.** The Recorder Power circuit provides operating voltage for the Printhead and the Motor Speed Control circuits by responding to a high logic signal from the Display/Recorder microprocessor at the base of Q2. This logic signal causes Q2 to conduct which turns on Q4, thereby supplying power for the recorder motor and printhead.

**Motor Speed Control.** Regulation of the recorder speed is necessary because of the variable drag on the recorder motor caused by the thermal printhead and the lack of a spindle on the paper roll. The paper speed of the recorder is regulated by a variable-frequency, pulse-width-modulation circuit that compares the back EMF (electromotive force) on the motor to a reference voltage. The circuit varies the frequency of the motor speed drive pulse enough to maintain the 25mm/s paper speed.

The back EMF produced in the motor when the drive pulse switches off determines the speed of the recorder motor. The voltage present at voltage dividers R18, R17, and C4 is directly proportional to the speed of the motor when Q3 is off. A frequency-modulated pulse from transistor Q3 drives the recorder motor. The pulse has a fixed on-time and a variable off-time. The off-time is set by comparator U2B and capacitor C4 and determines how much power Q3 conducts to the motor.

The fixed on-time is determined by U2C. When the off-time period is over, C2 has charged to a voltage level approximately 75% of VBATT. At the next on-time cycle, the output of U2B switches to ground, the voltage at U2C pin 10 goes to about 1/3 of VBATT, and C2 starts discharging through R7. U2C changes states and ends the pulse on-time when the voltage on C2 drops below the voltage on pin 10.

The voltage on U2B pin 7 is compared to a calibrated reference voltage at pin 6 to determine the off-time. During the on-time, C4 charges to a voltage proportional to the battery voltage. During the off-time, C4 discharges toward a voltage that is proportional to the back EMF of the motor. Under normal operating conditions, the voltage on C4 discharges over several time constants before the voltage on U2B pin 7 is equal to the reference voltage on pin 6. When the voltages are equal, the output of U2B switches low and Q3 conducts, supplying voltage to the motor. As the load on the motor increases, the back EMF voltage decreases and the pulse-width off-time gets shorter.

**Printhead Control.** Control of data to the recorder printhead is accomplished by the Display/Recorder microprocessor in conjunction with Recorder Gate Array U3, Program RAM U13, and Program EPROM U14. The Display/Recorder microprocessor receives data from the System microprocessor and formats it for transmission to the recorder printhead.

The Recorder Gate Array receives parallel data from the Display/Recorder microprocessor and transmits this data in serial form to the recorder

printhead. The printhead prints an array of 384 bits from the top to the bottom of the recorder paper. The Recorder Gate Array translates the two ECG signal data bytes from hexadecimal code to the 320 bits required by the printhead. Bytes for generating hexadecimal characters are mapped to the remaining 64 bits (32 for the top, 32 for the bottom) since text for the recorder always appears at fixed locations at the top or bottom of the recorder paper. As in the Display Gate Array, two internal trace generators receive high and low address inputs for the ECG trace and the SYNC marks.

The thermal printhead is an array of 384 switches and dots. An internal 384-bit shift register (see Figure 1-10) receives data input to the printhead. The Recorder Gate Array sends clock pulse CK to the printhead which enters data on the DI line into the shift register and converts the data from serial to parallel. The CK pulse is active only when data is sent to the printhead, thereby preventing the printhead shift register from running continuously. The source of the CK pulses is the E clock used by the System microprocessor and the Display/Recorder microprocessor.

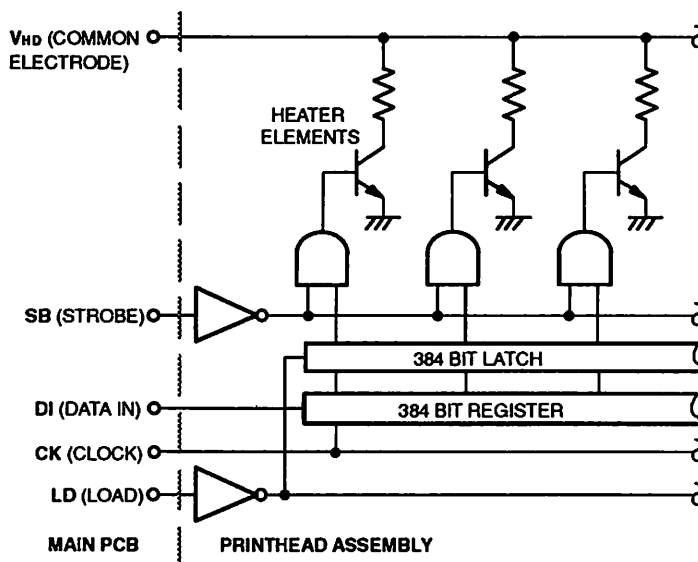


Figure 1-10 Printhead Assembly

The Display/Recorder microprocessor moves the data stored in the printhead shift register into the printhead latch via the LD line. Data in the shift register is loaded into a 384-bit latch with a high LD signal from the Display/Recorder microprocessor. The output of the latch is gated by 384 AND gates; the drive for the dot heating elements is provided by 384 NPN transistors. After the data is loaded into the latch, the Display/Recorder microprocessor Strobe line switches one input of the AND gates high. This causes the gates switched high (data = 1) on the other input to switch their

outputs high. The selected transistors conduct, dropping a voltage across their respective heating elements and activating the selected printhead dots.

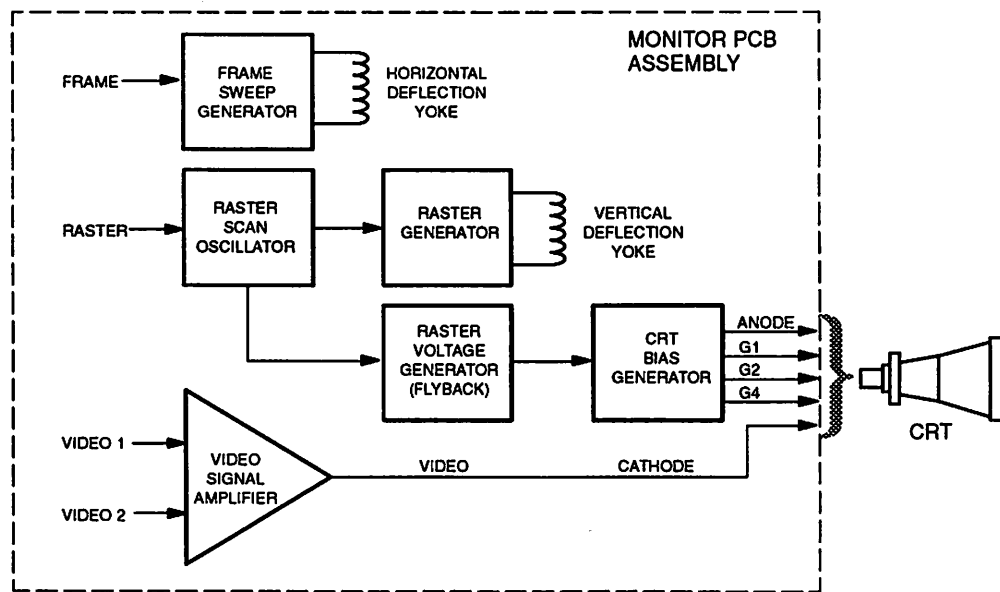
**Printhead Resistance Evaluation.** The Printhead Resistance Evaluation circuit is active only when the instrument is in motor speed calibration mode. When the motor speed calibration test runs, the Display/Recorder microprocessor starts energizing the printhead dots.

The measured printhead resistance used together with printhead temperature and voltage during printing determines the optimum duty cycle of the printhead. The printhead duty cycle is the time period that the printhead dots are energized; this is regulated by the width of the printhead strobe pulse, SB (see Figure 1-10). If the strobe pulse is too short, the print will be light; if it is too long, the excessive heat on the dots will greatly shorten the life of the printhead. The System microprocessor monitors the printhead resistance, battery voltage, and printhead temperature, and calculates the optimum printhead strobe width.

Monitoring the current through the printhead while increasing the number of dots turned on determines the printhead resistance. As the number of dots turned on increases, the combined resistance of the printhead decreases. Comparator U2A monitors the load on the VHD line at pin 5, through current sense resistor R27 and voltage divider R13 and R16. The VBATT line is monitored at pin 4 through voltage dividers R10 and R15. As the load on the printhead increases, the voltage across R16 decreases. When the voltage across R16 drops lower than the voltage across R15, U2A switches low. This directs the Display/Recorder microprocessor to stop sending strobe signals to the Recorder Gate Array at the  $\overline{\text{STROBE}}$  input. The Display/Recorder microprocessor then determines the printhead resistance from the number of dots turned on and passes this information to the System microprocessor.

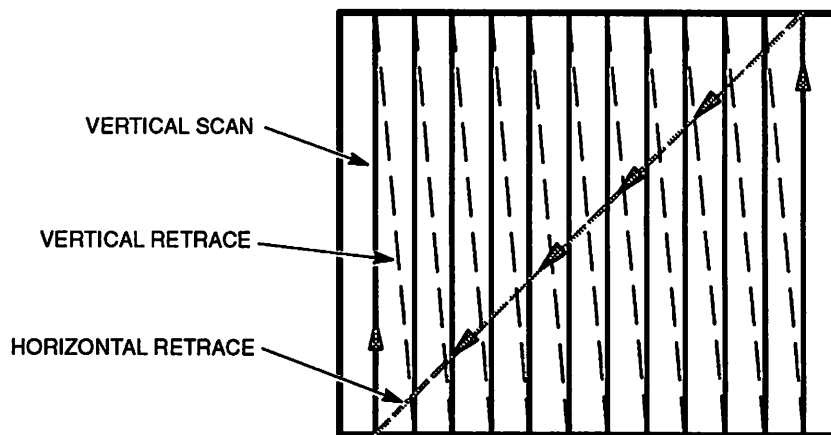
### **Display PCB/CRT Assembly (803706)**

The Display PCB/CRT Assembly (Figure 1-11) is composed of a CRT and the Monitor PCB Assembly. The Monitor PCB assembly processes video information and synchronization signals from the Main PCB and displays the information on the CRT. The incoming signals are Video 1, Video 2, and synchronization signals Frame Sync and Raster Sync.



**Figure 1-11 Display PCB/CRT Assembly Block Diagram**

Two separate circuits provide horizontal and vertical CRT beam deflection. The CRT raster consists of 768 scan lines in one complete frame with 256 pixels per line. The CRT screen is scanned by a vertical raster, bottom to top and left to right (see Figure 1-12). There is no interlacing during the raster scan.



**Figure 1-12 Display Scanning**

### Video Signal Amplifier

This circuit receives video information at the Video 1 and Video 2 inputs, controlling the voltage to the CRT cathode at the video output (J902 pin 2). The input to Video 1 and Video 2 is supplied from the Display Gate Array on the Main PCB at TTL voltage levels. The outputs of U401A, U401B, and U401C provide biasing for Q401, causing Q401 to conduct and supply a nominal +40V to the video output. Four levels of video intensity are available by switching the outputs of U401A, U401B, and U401C. Brightness is adjustable through Video Gain, R402.

### Frame Sweep Generator

A deflection hybrid IC, U101, drives the frame yoke to sweep the CRT during horizontal retrace. The Display Gate Array on the Main PCB supplies a nominal 60Hz synchronizing signal, Frame Sync, for this circuit.

To sweep the CRT accurately, U101 requires biasing by a number of external components. The RC combination, R105, R106, and C102, sets the frequency of the hybrids internal oscillator. Horizontal Hold, R106, controls horizontal rolling. Horizontal Width, R111, controls the width adjustment and Horizontal Linearity, R113, calibrates the CRT beam linearity. R128 senses deflection current and provides feedback to U101 pin 10 to help control both width and linearity. R117 and C112 form a damping circuit to eliminate yoke ringing (oscillation).

### Raster Scan Oscillator

The Raster Scan Oscillator sets the sweep frequency for the Raster Generator and the switching frequency for the Raster Voltage Generator power supply. The circuit is designed around voltage regulator U201.

The voltage regulator oscillator frequency is set to about 52kHz by the Raster signal. This signal is sent from the Display Gate Array on the Main PCB to Q201, causing Q201 to conduct and pass the signal to U201 pin 5. Resistor R217 and capacitor C203 function as an RC network, slowing the current at power-on. Resistor R209 decouples the +15V supply voltage so that display size will be minimally affected by changes in the +15V supply.

Input overvoltage protection is provided by Q201, Q202, and D201. If the input voltage rises to 18V or greater, D201 starts to conduct. This signal forward-biases Q203 which routes it to the gate of Q202. When Q202 conducts, it inhibits the internal oscillator in U201 by applying +5V to the input at pin 4.

Vertical Size, R224, controls the width of the pulse from the output stage of U201 which determines the amount of energy delivered to transformer T301.

### Raster Voltage Generator

The Raster Voltage Generator supplies the input voltage for the primary of T301 as well as overall CRT bias voltages. The input signal for the circuit comes from the output of voltage regulator U201 pin 10 in the Raster Scan Oscillator circuit.



The Raster Voltage Generator circuit is designed around transformer T501 and transistors Q501 and Q502. The oscillating output of U201 drives Q501, providing additional current for Q502. The output of Q502 sets the voltage for the primary of T301. The +15V input at T501 pin 4 produces  $\pm 15V$  (30V total) output at pin 5. A tap at T501 pin 6 supplies +24V. The secondary winding on T1 adds +14V to boost the +24V to +40V output at T501 pin 8. This voltage provides a ground reference for biasing G1, G2, and G4.

#### Raster Generator

Vertical deflection for the raster yoke is provided by the Raster Generator circuit. Because of high current and voltage requirements, the vertical deflection circuit consists of discrete components, forming a resonant circuit. The Raster Generator, like the Raster Voltage Generator, is driven from the Raster Scan Oscillator circuit. The Raster Generator circuit includes transformer T301, which is shared with the CRT Bias Generator and provides the drive signal for the 88mH yoke coil. This creates the vertical scan drive for the CRT.

The Display Gate Array on the Main PCB supplies the synchronizing signal, Raster, which is passed to voltage regulator U201. The output of U201 pin 9 causes Q204 to conduct, providing additional current for Q205. The output of Q205 controls the charge and discharge of C208 through C212. The precise values of these capacitors are essential for maintaining the proper resonance while charging and discharging. Transformer T301 provides high voltage for charging the capacitors.

#### CRT Bias Generator

The CRT Bias Generator supplies half-wave rectified voltage for the CRT anode and grid from the output of transformer T301. It provides up to -150V for bias of G1, up to +700V for bias of G2 and G4, and between +8.5kV and +11.6kV for anode bias. Master Brightness, R302, adjusts the brightness which largely determines the general background brightness of the CRT. Focus, R306, adjusts the focus.

---

## Introduction

This section provides information about the basic operation of the instrument. It is not intended to instruct an operator in the clinical use of the instrument. For clinical use, refer to the separate *Operating Instructions* manual. This section includes information about the following:

- Front Panel Controls and Indicators, including Paddles Area
- Rear Panel Controls, Indicators and Connectors
- Option Settings, including self-tests and power-on default settings
- Clock Setting Procedure.

---

## Controls and Indicators

LIFEPAK 9 defibrillator/monitor controls and indicators are identified in Figures 2-1 and 2-2 and described in the corresponding Tables 2-1 and 2-2.

*Note:* Pushbuttons are indicated in sans-serif CAPITAL LETTERS and displayed messages are indicated in **BOLD CAPITAL LETTERS**.

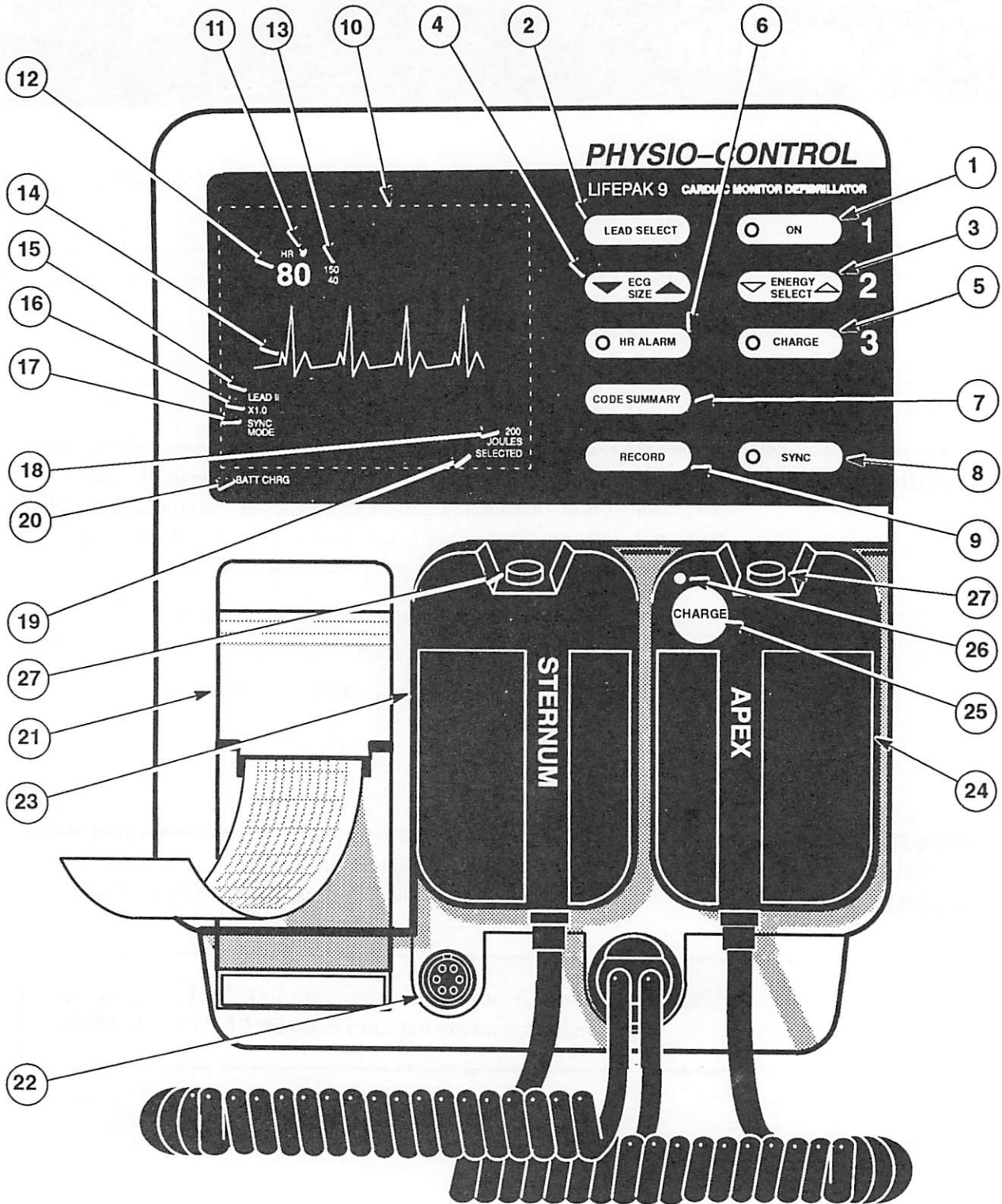


Figure 2-1 Front Panel Controls and Indicators

Table 2-1 Front Panel Controls and Indicators (cont.)

Item	Control or Indicator	Function
21	Recorder	Records ECG and annotation in delay ECG mode only. Prints date, time, sync mode (if active), ECG lead, ECG gain, and heart rate. Prints selected energy and defibrillation mode during defibrillation. Records automatically for 16 seconds whenever a heart rate alarm violation occurs.
<b>PADDLES AREA</b>		
22	Patient Cable Connector	Connection for 6-pin patient cable.
23	STERNUM Paddle	Defibrillation electrode with one discharge pushbutton, usually placed to left of sternum (patient's right). Also serves as negative ECG electrode during QUIK-LOOK paddle monitoring.
24	APEX Paddle	Defibrillation electrode with QUIK-CHARGE control (CHARGE) and one discharge pushbutton, usually placed near cardiac apex. Also serves as positive ECG electrode during QUIK-LOOK paddle monitoring.
25	CHARGE (QUIK-CHARGE control)	Momentary pushbutton to charge defibrillator from APEX paddle.
26	Charge Indicator	LED flashes during charge and glows steadily when energy has reached selected level.
27	Discharge Pushbuttons	Pushbuttons to discharge energy. <u>Both</u> pushbuttons must be pressed <u>simultaneously</u> to deliver energy to the paddles. <b>ENERGY WILL NOT BE DELIVERED UNLESS THE INSTRUMENT IS FULLY CHARGED TO SELECTED LEVEL.</b>
28	Test Load (not shown)	50Ω defibrillator test load. Metal contacts (not shown, in paddles storage area) for receiving defibrillation discharge energy from paddles.

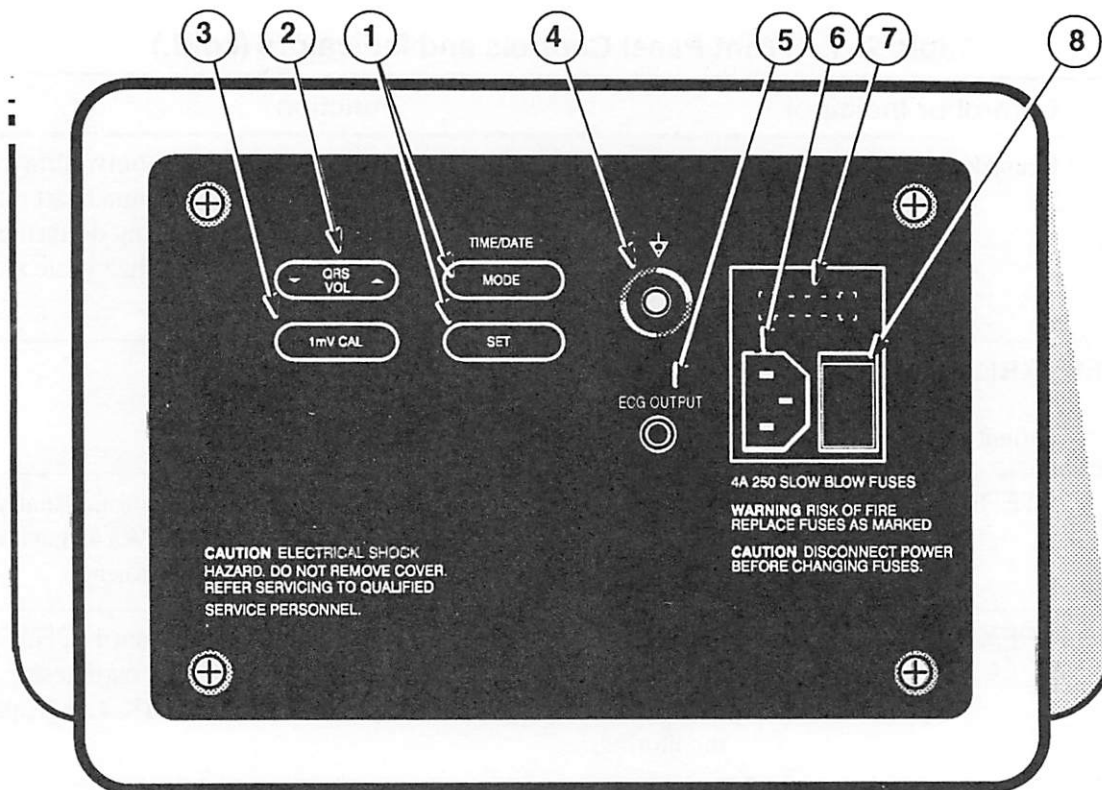


Figure 2-2 Rear Panel Controls, Indicators, and Connectors

Table 2-2 Rear Panel Controls, Indicators, and Connectors

Item	Function	
1	TIME/DATE MODE  SET	Pushbuttons for setting the real-time clock. Pressing once selects the clock setting mode. Pressing repeatedly selects minutes, hour, year, month, day fields. Pressing again exits the clock setting mode. Pressing advances the value displayed in the selected clock set field.
2	▼ QRS VOL ▲	Pressing the up or down scroll pushbutton increases or decreases the QRS volume. The last setting is retained when power is off.
3	1mV CAL	Pressing displays a 1mV calibration signal on the CRT and recorder.
4	Ground	Equipotential ground tie point.
5	ECG OUTPUT	ECG out connector; 1V/mV output with ECG gain of 1 (press ECG SIZE to set gain).
6	AC Power Connector	AC power connector.
7	Fuse Cover	Access panel for changing fuses.
8	Mains Power	Rocker switch turns ac line power on (I) or off (O). On some models a clip is installed which locks this switch in the on position.

## Option Settings

The LIFEPAK 9 defibrillator/monitor includes software which allows the user to initiate self-tests, change settings and power-on defaults such as language and heart rate alarm limits, and examine system data. Access for all of these options is gained through the top-level Test Menu which then allows access to the Setup Menu or Info Menu. All menus and options are described below.

## Test Menu

The Test Menu is the top-level menu which allows access to the self-tests and the two other menus, the Setup Menu and the Info Menu. To access the Test Menu, do the following:

1. Make sure the defibrillator/monitor power is off. Simultaneously press and hold LEAD SELECT and HR ALARM, then press ON.
2. Continue holding LEAD SELECT and HR ALARM until the message **SELECTED TEST:** and a list of tests are displayed as shown in Figure 2-3. This information is the Test Menu.

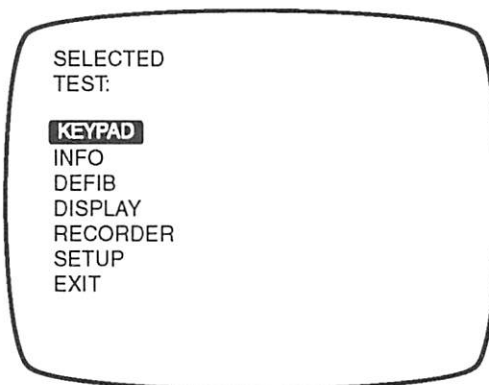


Figure 2-3 Test Menu

The Test Menu allows access to the four self-tests (**KEYPAD**, **DEFIB**, **DISPLAY**, and **RECORDER**), the Info Menu (**INFO**), and the Setup Menu (**SETUP**). The self-tests are executed as part of the Performance Inspection Procedure and the Test and Calibration Procedure and are described in detail in Section 3. The Info Menu and the Setup Menu are described in the following paragraphs.

To exit the Test Menu and return to normal operation, press ▼ ECG SIZE to scroll down to **EXIT**, then press HR ALARM.

## Setup Menu

The Setup Menu allows you to examine and change various operating settings such as the language, notch filters, heart rate alarm limits, and the alarm volume. To access the Setup Menu, do the following:

1. First, access the Test Menu by turning power off. Then simultaneously press and hold LEAD SELECT and HR ALARM while pressing ON.
2. After the Test Menu appears as shown in Figure 2–3, press ▼ ECG SIZE to scroll down to **SETUP**. Then press HR ALARM to display the Setup Menu as shown in Figure 2–4.

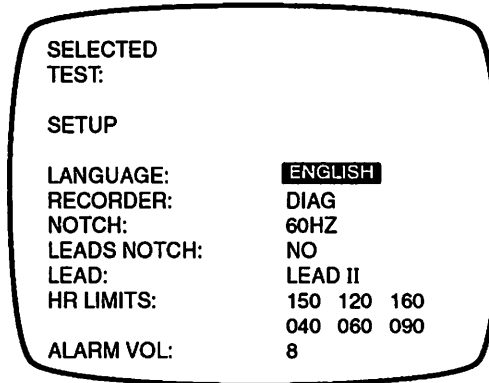


Figure 2–4 Setup Menu

The different option settings are as follows:

<b>LANGUAGE:</b>	ENGLISH, FRENCH, GERMAN, or SPANISH
<b>RECORDER:</b>	MONitor or DIAGnostic
<b>NOTCH:</b>	50Hz or 60Hz
<b>LEADS NOTCH:</b>	YES or NO
<b>LEAD:</b>	PADDLES or LEAD II
<b>HR LIMITS:</b>	3 limits can be configured from the following ranges: 80bpm to 240bpm and 20bpm to 100bpm.
<b>ALARM VOL:</b>	1 to 8 (A short tone sounds with each level change to indicate the selected volume.)

3. Press HR ALARM to scroll through the selections. Press ▼ ECG SIZE ▲ to scroll through the different option settings.
4. After you choose the desired option setting, press HR ALARM again to store the setting and move to the next selection. Whatever options are selected become the power-on default settings.
5. To exit the Setup Menu and return to the Test Menu, press LEAD SELECT. To exit the Test Menu and return to normal operation, press ▼ ECG SIZE to scroll down to **EXIT**, then press HR ALARM.

## Info Menu

The Info Menu allows you to examine the manufacturing date and EPROM revision numbers, and to examine and clear the number of defibrillator discharges recorded and fault status codes recorded. To access the Info Menu, do the following:

1. First, access the Test Menu. Turn power off, then simultaneously press and hold LEAD SELECT and HR ALARM while pressing ON.
2. After the Test Menu appears as shown in Figure 2-3, press ▼ ECG SIZE to scroll down to **INFO**. Then press HR ALARM to display the Info Menu as shown in Figure 2-5.

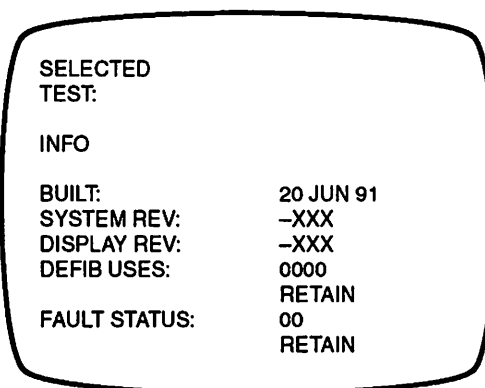


Figure 2-5 Info Menu

- |                      |   |
|----------------------|---|
| <b>BUILT:</b>        | Manufacturing date (user cannot change).  |
| <b>SYSTEM REV:</b>   | Revision number for system microprocessor EPROM; changes automatically with any EPROM update (user cannot change).                        |
| <b>DISPLAY REV:</b>  | Revision number for the display/recorder microprocessor EPROM; changes automatically with any EPROM update (user cannot change).          |
| <b>DEFIB USES:</b>   | Records the number of defibrillator discharges; user may <b>RETAIN</b> or <b>CLEAR</b> the number.  |
| <b>FAULT STATUS:</b> | Retains any coded instrument errors using the error codes listed in Section 3 on page 3-40; user may <b>RETAIN</b> or <b>CLEAR</b> codes. |

3. Press HR ALARM to scroll through the selections. For **DEFIB USES:** or **FAULT STATUS:**, press ▼ ECG SIZE ▲ to toggle between **CLEAR** and **RETAIN**.
4. To exit the Info Menu and return to the Test Menu, press LEAD SELECT. To exit the Test Menu and return to normal operation, press ▼ ECG SIZE to scroll down to **EXIT**, then press HR ALARM.



## Clock Setting Procedure

To set the clock which is displayed on the CRT and recorder, do the following:

1. Press TIME/DATE MODE on the rear panel to initiate the clock setting mode. The monitor displays the current clock setting in the lower left corner of the CRT as shown in Figure 2-6. The single minutes field is highlighted.
2. Press TIME/DATE SET on the rear panel to change the single minute setting. Each time the pushbutton is pressed, the value of the field increases by one increment.
3. Press MODE again to advance to the next field. Press SET to select the desired value. Repeat this to set the entire time and date.
4. To exit the clock setting mode, press MODE again after selecting the day field.

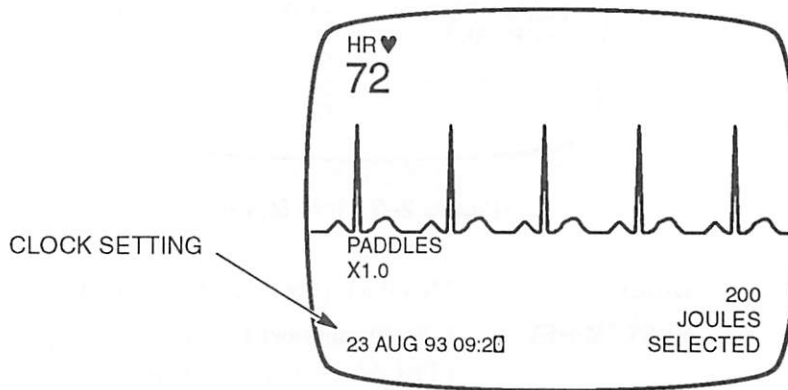


Figure 2-6 Clock Set Display

---

## Introduction

This section describes how to test, calibrate, and troubleshoot the LIFEPAK 9 defibrillator/monitor. Topics cover:

- The Performance Inspection Procedure (PIP)
- The Test and Calibration Procedure (TCP)
- Troubleshooting Aids.

*Note:* Prefixes are used to distinguish testing steps.

**PIP**— identifies Performance Inspection Procedure steps.

**TCP**— identifies Test and Calibration Procedure steps.

---

## Performance Inspection Procedure (PIP)

This Performance Inspection Procedure (PIP) checks whether a LIFEPAK 9 defibrillator/monitor is performing within specifications. The defibrillator/monitor case does not need to be opened to perform the PIP. The PIP Checklist (page 3-18) may be photocopied and used to record the PIP results. If the defibrillator/monitor fails any part of the PIP, refer to the Test and Calibration Procedure (page 3-20) and the Troubleshooting Aids (page 3-40) for help in locating any failed subassemblies.

### PIP-Purpose

This PIP checks whether the LIFEPAK 9 defibrillator/monitor is performing within specifications. Perform the PIP regularly as a periodic maintenance check and after any repair or calibration.

**PIP-Scope and Applicability**

This PIP applies to all configurations of the LIFEPAK 9 defibrillator/monitor. This PIP does *not* apply to the LIFEPAK 9A, LIFEPAK 9B, or LIFEPAK 9P defibrillator/monitors; refer to their respective service manuals for testing information.

**PIP-Definitions**

Acronyms used in this procedure are:

<b>BPM</b>	Beats Per Minute
<b>ECG</b>	Electrocardiogram
<b>PIP</b>	Performance Inspection Procedure
<b>QRS or QRS Complex</b>	Refers to portions of the ECG waveform
<b>NSR</b>	Normal Sinus Rhythm
<b>p-p</b>	peak-peak

*Note: Pushbuttons are indicated in CAPITAL LETTERS and displayed messages are indicated in **BOLD CAPITAL LETTERS**.*

**PIP-Requirements**

The requirements for test equipment, workstation, and personnel are listed below along with important safety information.

**PIP-Required Equipment**

Performing this PIP requires the equipment listed in Table 3-1. Although specific test instruments are recommended, other test equipment with equivalent specifications may be used.

**Table 3-1 PIP Test Equipment**

<b>Equipment</b>	<b>Specifications</b>	<b>Manufacturer</b>
Defibrillator Energy Meter	Power Range: 0-400J Load Resistance: $50\Omega \pm 1\%$ Accuracy: $\pm 3\%$ Defib Waveform Amplitude Attenuation: 1000:1 (minimum) with oscilloscope output	Bio-Tek QED-6 or equivalent*
ECG simulator	Accuracy: 1% of selected rate	Bio-Tek QED-6 or equivalent*
Leakage Tester/ Safety Analyzer	110Vac Line Voltage: Current Range: 0-2000 $\mu$ A Current Accuracy: $\pm 1\%$ Resistance Accuracy: $\pm 1\%$  230Vac Line Voltage: Current Range/Accuracy: 200 $\mu$ A/5% of reading 2000 $\mu$ A/1% of reading Resistance Accuracy: $\pm 1\%$	Dynatech Nevada 232, or equivalent*  Dynatech Nevada 432 HD, or equivalent*

\*Equivalent equipment is required to meet the specifications listed in the specifications column.

Table 3-1 PIP Test Equipment (cont.)

Equipment	Specifications	Manufacturer
Patient Cable	3-lead, AHA or 3-lead, IEC	Physio-Control PN 9-10418-02 Physio-Control PN 800947-01
Recorder paper	50mm (use only Physio-Control paper)	Physio-Control PN 804700
Metric ruler or recorder paper	Resolution: 1mm divisions	
Timer	1 second resolution	Aristo or equivalent

\*Equivalent equipment is required to meet the specifications listed in the specifications column.

**Caution**

**Possible Equipment Damage.** Be sure to use **only** recorder paper from Physio-Control (PN 804700). Other paper may damage the printhead and may not print legibly.

## PIP-Test Equipment Verification

All test equipment used in performing the PIP must have a current calibration label affixed to its exterior. The calibration label must be issued by a certified calibration facility.

## PIP-Workstation

The ac line power for this workstation must be connected to a grounded power source.

## PIP-Personnel

Personnel performing this PIP must be thoroughly familiar with the operation of the LIFEPAK 9 defibrillator/monitor. In addition, personnel performing this PIP must meet at least one of the following levels of education or experience:

- Associate of applied science degree with a major emphasis in biomedical electronics
- Certificate of technical training in electronics with a major emphasis in biomedical electronics
- Equivalent biomedical electronics experience.

**Warning**

**SHOCK HAZARD.** When charged and discharged during this PIP, the LIFEPAK 9 defibrillator/monitor discharges up to 360J of electrical energy through the defibrillator paddles. Unless discharged properly as described in this PIP, this electrical energy may cause injury or death. Do not attempt to perform this procedure unless you are thoroughly familiar with the operation of the LIFEPAK 9 defibrillator/monitor.

## Warning

**POSSIBLE ARCING AND PADDLE DAMAGE.** When discharging the defibrillator into the internal test load, make sure the standard paddles are securely and properly stored in the paddle storage area (STERNUM paddle on the left, APEX paddle on the right). This helps prevent arcing and formation of pits on paddle electrode surfaces. Pitted or damaged paddle electrode surfaces can cause patient skin burns during defibrillation.

**PIP-General Instructions** The following sections are the actual PIP steps to be performed. These steps are designed to be executed in sequential order. For instance, if a heart rate input of 30bpm is specified for one test it also applies to the next test unless you are instructed to change it.

**PIP-Physical Inspection** Before beginning the PIP-Physical Inspection, be sure to disconnect the ac power cord from the ac power source.

- Inspect all exterior surfaces for signs of abuse or other damage, including fluid spills, cracks and dents.
- Inspect paddles for pitted electrode plates, presence of dried defibrillation gel, and integrity of cables and switches. Remove gel or other foreign matter from paddles and paddle wells.
- Inspect recorder for ease of door operation and positive latching. Remove dust or foreign matter inside recorder.
- Inspect all external connections for bent, broken, or corroded pins, and debris.
- Inspect the power cord and all cables and accessories for damage, cracks, breaks, bent or broken connector pins, or other signs of wear.
- Open the battery door on the bottom of the defibrillator/monitor and make sure batteries are installed. Close the door and make sure it latches properly.
- Press the ON pushbutton and confirm that the green LED illuminates. Press ON again and make sure the green LED is off and power is off (the display is blank). Then press all other pushbuttons and check them for uniform mechanical resistance.

## PIP-AC Power

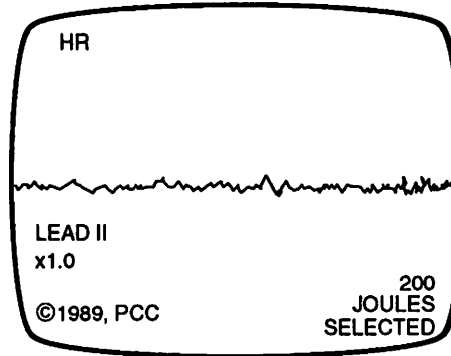
1. Connect the defibrillator/monitor to ac power.
2. If the dash number of the defibrillator/monitor is listed below, confirm that the power module clip is installed at the bottom of the rear panel power switch, locking the switch to the power on (I) position. Then go on to step 3.

### Dash Numbers with Power Module Clip Installed

803800-09	803800-300
803800-18	803800-309 thru -312
803800-28	803800-314 thru -316

If the dash number of the defibrillator/monitor is *not* listed above, press the bottom of the rear panel power switch to place it in the on (I) position.

3. Press ON to apply power to the defibrillator/monitor and confirm that the ON LED illuminates.
4. Confirm that © 1989, PCC is displayed for at least 5 seconds.
5. Confirm that within 10 seconds after the defibrillator/monitor is turned on, the monitor displays power-on information as shown in Figure 3-1.



**Figure 3-1 Power-On Display**

### PIP-Battery Charge

With defibrillator/monitor power on and the ac power source connected, confirm that **BATT CHRG** is displayed in the lower left corner of the display.

### PIP-Battery Power

1. With defibrillator/monitor power on, disconnect the power cord from the ac power source. Confirm that the display remains on but **BATT CHRG** is not displayed.
2. Reconnect the ac power cord and press ON to turn off defibrillator/monitor power.

### PIP-Setup Menu Settings

This procedure describes how to access the Setup Menu and select the proper settings required for the rest of the PIP. Before changing any settings, write down the current settings so you can restore these settings at the completion of the PIP.

1. To access the Setup Menu, make sure defibrillator/monitor power is off. Simultaneously press and hold LEAD SELECT and HR ALARM, then press ON.
2. Continue holding LEAD SELECT and HR ALARM until the message **SELECTED TEST:** and a list of tests are displayed as shown in Figure 3-2. This information is the Test Menu.

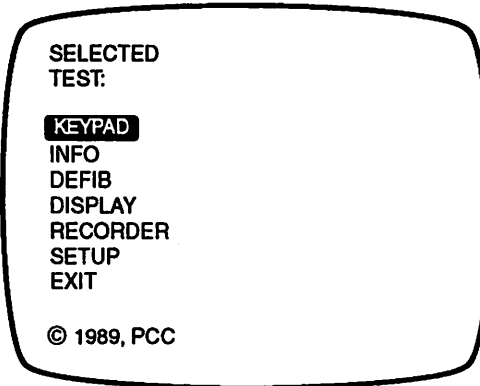


Figure 3-2 Test Menu

3. Press ▼ ECG SIZE ▲ to scroll through the Test Menu. Scroll to **SETUP** and then press HR ALARM to display the Setup Menu as shown in Figure 3-3. Before changing any settings, write down the current user settings so you can restore them after completing the PIP.

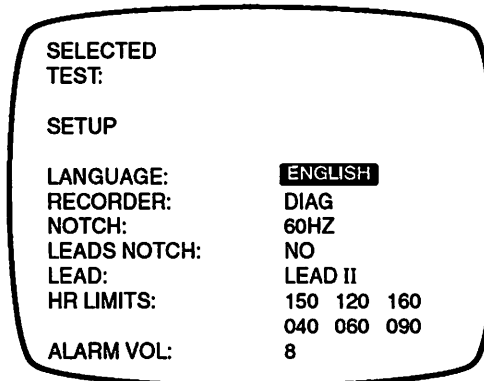


Figure 3-3 Setup Menu

4. Press HR ALARM to scroll through the available selections. Press ▼ ECG SIZE ▲ to change an option selection. Select:
 

<b>LANGUAGE:</b>	Match local requirements
<b>RECORDER:</b>	<b>DIAG</b>
<b>NOTCH:</b>	Match local line requirements
<b>LEADS NOTCH:</b>	<b>NO</b>
<b>LEAD:</b>	<b>LEAD II</b>
<b>HR LIMITS:</b>	<b>150    120    160</b>
	<b>040    060    090</b>
<b>ALARM VOL:</b>	<b>8</b>
5. To exit and store the changes, press HR ALARM to scroll back to **LANGUAGE:**, then press LEAD SELECT to return to the Test Menu. Leave the Test Menu displayed for the next test, PIP-Keypad Test.

## PIP-Keypad Test

1. The Keypad Test is initiated from the Test Menu (as shown in Figure 3-2) which should be displayed from the end of the previous step. Press ▼ ECG SIZE ▲ to scroll to **KEYPAD**, then press HR ALARM to start the Keypad Test.
2. Press the front panel pushbuttons and then the rear panel pushbuttons in the following order:

### Front Panel:

LEAD SELECT

▼ ECG SIZE

ECG SIZE ▲

▼ ENERGY SELECT

ENERGY SELECT▲

HR ALARM

CHARGE

CODE SUMMARY

RECORD

SYNC

### Rear Panel:

▼ QRS VOL

QRS VOL ▲

MODE

1mV CAL

SET

3. Press the APEX paddle CHARGE pushbutton.
4. Press the APEX paddle discharge pushbutton; confirm no beep sounds.
5. Press the STERNUM paddle discharge pushbutton; confirm no beep sounds.
6. Simultaneously press both paddle discharge pushbuttons; confirm that a beep sounds.
7. Confirm that the monitor displays **KEYPAD: OK**, then press LEAD SELECT to return to the Test Menu. If the pushbuttons are not pressed in the order listed above, or if there is a pushbutton failure, the monitor displays **KEYPAD: FAULT**. In this case, press ▼ ECG SIZE ▲ to scroll to **KEYPAD**, then press HR ALARM to restart the Keypad Test and repeat steps 2 through 7.
8. To exit the Keypad Test after completion, press ▼ ECG SIZE ▲ to scroll to **EXIT** and press HR ALARM to resume normal operation.



**PIP-Lead Select**

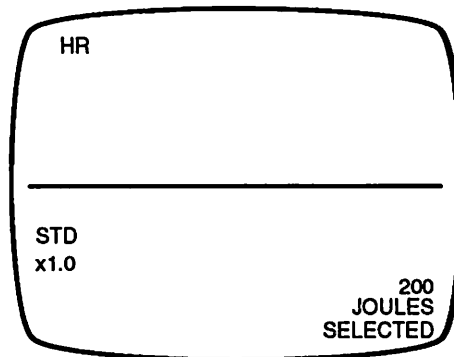
1. Use the patient cable to connect the ECG simulator to the defibrillator/monitor. Set the ECG simulator for a 60 bpm-NSR signal.
2. Press LEAD SELECT repeatedly and confirm that the signal displays in all lead (I, II, III) configurations.

**PIP-Recorder  
Speed/Baseline  
Centering**

1. Confirm there is paper in the recorder.
2. Set the ECG simulator for a 60bpm-NSR signal in LEAD II.
3. Press RECORD, let the recorder run for approximately 10 seconds, then select STD. Let the recorder run for an additional 10 seconds, then press RECORD to stop the recorder.
4. Measure the distance between the maximum peaks of the recorded ECG trace. Confirm that the distance between consecutive peaks is  $25 \pm 1$ mm.
5. Measure the baseline centering of the recorded STD trace. Confirm that the baseline is centered within  $\pm 1$ mm.

**PIP-ECG Display**

Confirm that the flatline display on the CRT appears level and centered.  
Confirm that all messages are clearly visible as shown in Figure 3-4.

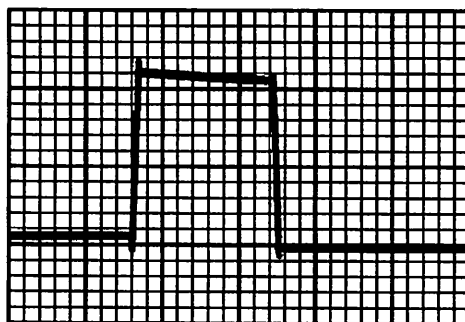


**Figure 3-4 Display with Flatline ECG Trace**

**PIP-1mV CAL**

In order to perform this test the **LEADS NOTCH** must be set to **NO** and the recorder must be set to **DIAG** as described in the PIP-Setup Menu Settings on page 3-5.

1. Confirm that the **STD** lead remains selected from the previous PIP test (press **LEAD SELECT** if necessary to select **STD**).
2. Press **RECORD**, then press the **1mV CAL** pushbutton on the rear panel once. Confirm that a  $10.0 \pm 0.5$ mm p-p calibration pulse is printed out as illustrated in Figure 3-5.



**Figure 3-5 1mV CAL Pulse**

**PIP-CRT Gain/Aspect Ratio**

1. Select **LEAD II**.
2. Set the ECG simulator for a 60bpm-NSR signal.
3. Adjust ▼ **ECG SIZE** ▲ for a  $34 \pm 2$ mm p-p ECG display signal.
4. Press **RECORD**.
5. Confirm that the signal amplitude printed on the ECG paper is  $20 \pm 1$ mm p-p.

**PIP-Heart Rate**

1. With **LEAD II** selected, set ECG Size to **X1.0**.
2. Set the ECG simulator for the input rates listed below. Confirm that the systole indicator (the heart-shaped symbol) flashes on the display with each QRS complex and that the displayed HR corresponds:

Input Rates (bpm)	HR
30	$30 \pm 2$ bpm
60	$60 \pm 2$ bpm
240	$240 \pm 5$ bpm

3. Return the ECG simulator selection to 60bpm-NSR.

### PIP-Rate Alarms/ Alarm-Activated Record

1. Press HR ALARM. Confirm that the HR ALARM LED is on and **150/40** is displayed in reverse video.
2. While **150/40** remains displayed in reverse video, press HR ALARM twice and confirm that **120/60** and **160/90** display consecutively.
3. Press HR ALARM to display **150/40** in reverse video. Confirm that after about 2 seconds **150/40** displays in normal video.
4. Set the ECG simulator rate to greater than 150bpm. Confirm that the alarm sounds, the **150** flashes, and the recorder runs for approximately 16 seconds.
5. Confirm that the heart rate printed on the printout is 151bpm or higher.
6. Press HR ALARM and confirm that the alarm stops.
7. Decrease the ECG simulator rate to 30bpm. Press HR ALARM. Confirm that the alarm sounds, the **40** flashes, and the recorder runs for approximately 16 seconds.
8. Press HR ALARM and confirm that the alarm stops.

### PIP-Recorder Annotation/ Real-Time Clock

1. Set the ECG simulator to 60bpm.
2. Set the defibrillator/monitor to local time. (Press TIME/DATE MODE on the rear panel to display the clock setting; press TIME/DATE SET to increment to the desired value in the displayed field, then press TIME/DATE MODE to advance to the next field.)
3. Press RECORD and confirm the recorder begins printing with the date and time annotated.
4. Confirm that the time is accurate to within  $\pm 1$  minute.
5. Press RECORD to stop the recorder.

### PIP-Test Load

1. Make sure the paddles are stored in the paddle storage area of the defibrillator/monitor.
2. Press ▼ ENERGY SELECT ▲ as necessary to set the energy level to 200J.
3. Press CHARGE.

### PIP-Sync/Sync Annotation

4. After the defibrillator reaches full charge, simultaneously press both paddle discharge pushbuttons to transfer the energy into the test load. Confirm that **TEST 200 JOULES DELIVERED** displays on the monitor and annotates on the recorder printout.
1. Press LEAD SELECT to set the defibrillator/monitor to **LEAD II**. Set the ECG simulator for a 60bpm-NSR signal.
  2. Press SYNC. Confirm that **SYNC MODE** displays on the CRT, the sync marker (the inverted triangle) is clearly visible on each displayed R wave, and the SYNC pushbutton LED flashes.
  3. Place the paddles in the paddle storage area of the defibrillator. Press **▼ ENERGY SELECT ▲** if necessary to set the energy level to 200J.
  4. Press CHARGE. After the defibrillator reaches full charge, simultaneously press and hold both paddle discharge pushbuttons until the energy is discharged into the test load.
  5. Confirm that the recorder prints the message **SYNC TEST 200 JOULES DELIVERED** and the sync markers are clearly visible on each R wave on the printed ECG trace.
  6. Confirm that the **SYNC MODE** display and SYNC pushbutton LED are off, and no sync markers are visible.

### PIP-Recorder/CRT Noise

1. Short together the RA and LL leads of the patient cable.
2. Set the ECG gain to X4.0. Select **LEAD II**.
3. Press RECORD to start the recorder.
4. Confirm that the CRT and recorder baseline noise is less than 3mm p-p.
5. Select **PADDLES** electrodes. Short the paddle plates together, wait at least 10 seconds, and then confirm that the CRT and the recorder baseline noise is less than 3mm p-p.

*Note: The ECG signal that is displayed on the CRT is delayed approximately 10 seconds before being printed by the recorder.*

6. Return the paddles to the paddle storage area. Press RECORD to turn off the recorder.

### PIP-Defib Disarm and CHARGE LEDs Check

1. Press ▼ ENERGY SELECT ▲ and set the energy level to 0J.
2. Press the CHARGE pushbutton.
3. Confirm that the CHARGE LED does not light and that the CRT continues to display **0 JOULES SELECTED**.
4. Press ▼ ENERGY SELECT ▲ to set the selected energy to 200J.
5. Press CHARGE and confirm that both the front panel and the APEX paddle CHARGE LEDs flash during the charge cycle.
6. Confirm that the LEDs remain on and a tone sounds when full charge is reached.
7. Simultaneously press both paddle discharge pushbuttons to transfer the charge. Confirm that the CHARGE LEDs are off and the recorder prints the message **TEST 200 JOULES DELIVERED**.

### PIP-Paddle Polarity

1. Set the ECG simulator for a 60bpm-NSR signal.
2. Press LEAD SELECT to select **PADDLES** lead and remove the paddles from the paddles storage area.
3. Hold the paddles on the ECG simulator output connections (APEX on LL, STERNUM on RA) and confirm that a positive-going QRS complex is visible on the CRT.
4. Return the paddles to the paddle storage area.

### PIP-Charge Time

1. Press ▼ ENERGY SELECT ▲ to set the energy level to 360J. Make sure the paddles are securely stored in the paddle storage area.
2. Simultaneously press CHARGE and start the timer. Stop the timer when the defibrillator reaches full charge (as indicated by the tone and the displayed message **360 JOULES AVAILABLE**). Confirm that the charge time is less than 10 seconds.
3. Press the paddle discharge pushbuttons simultaneously to transfer the energy into the test load. Confirm that **TEST USE 200 JOULES** displays on the CRT and three tones sound.

**PIP-Discharge Control**

1. Press ▼ ENERGY SELECT ▲ to set the energy level to 360J.

**Warning**

**SHOCK HAZARD.** Help avoid injury by holding the paddles and coil cords away from your body and away from any other person or object as described in the following steps.

2. Remove the paddles from the paddle storage area. Extend the coil cords away from the paddle wells at least three feet and away from your body or any other object. Press CHARGE.
3. After the defibrillator reaches full charge (indicated by the tone and the displayed message **360 JOULES AVAILABLE**) keep the coil cords **extended and away from your body or any other object** while shaking the paddles and coil cords with a moderate motion. Confirm that no discharge occurs.
4. Return the paddles to the paddle storage area.
5. Simultaneously press both discharge pushbuttons and confirm that the energy is discharged into the test load.

**PIP-Energy Dump**

1. Place the paddles on the energy meter electrodes.
2. Press ▲ ENERGY SELECT ▼ and set the energy level to 360J.
3. Press CHARGE.
4. After the defibrillator/monitor charges to 360J, change the energy level to 300J.
5. Confirm **CHARGE REMOVED** is displayed and tones sound. Return the paddles to the paddle storage area.

**PIP-Charge Reduction**

1. Leave the paddles stored in the paddle storage area. Press ▲ ENERGY SELECT ▼ and set the energy level to 360J.
2. Press CHARGE.
3. When full charge is reached, start the timer and immediately change the energy level to 1J and press CHARGE (to perform this test properly, you should scroll to 1J and press CHARGE within a few seconds).
4. Confirm that full charge of 1J is reached within 20 seconds or less after you start the timer. Simultaneously press both discharge pushbuttons and confirm that the energy is discharged into the test load.

**PIP-Delivered Energy**

Connect the paddles to the energy meter electrodes. Refer to Table 3-2 and confirm that the delivered energy is within tolerances for each energy level.

**Table 3-2 Delivered Energy Tolerances**

Energy Setting	Tolerance	Energy Setting	Tolerance
1J	±0.2J	10J	±1.0J
2J	±0.2J	20J	±2.0J
3J	±0.3J	30J	±2.1J
4J	±0.4J	50J	±3.5J
5J	±0.5J	100J	±7.0J
6J	±0.6J	200J	±14.0J
7J	±0.7J	300J	±21.0J
8J	±0.8J	360J	±25.2J
9J	±0.9J		

**PIP-CODE SUMMARY  
Report**

1. Press ON twice to switch defibrillator/monitor power off then on.
2. Place the paddles on the energy meter electrodes. Press LEAD SELECT to set the defibrillator/monitor to **LEAD II**.
3. Connect the ECG simulator to the patient cable and set for a 60 bpm-NSR signal.
4. Press SYNC.
5. Press ▲ ENERGY SELECT ▼ and set the energy level to 200J.
6. Press CHARGE. When full charge is reached (as indicated by the tone and displayed message **200J AVAILABLE**), simultaneously press both paddle discharge pushbuttons to transfer the energy into the energy meter.
7. Press RECORD twice to switch the recorder on, then off quickly.
8. Press CODE SUMMARY.
9. Confirm that the format and appearance of the recorded data is similar to the data shown in Figure 3-6.

NAME	COMMENTS
<b>CODE SUMMARY™</b>	
<b>CRITICAL EVENT RECORD</b>	
19 NOV 91	
POWER ON	14:27:35
TOTAL SHOCKS	1
ELAPSED TIME	01:12:49

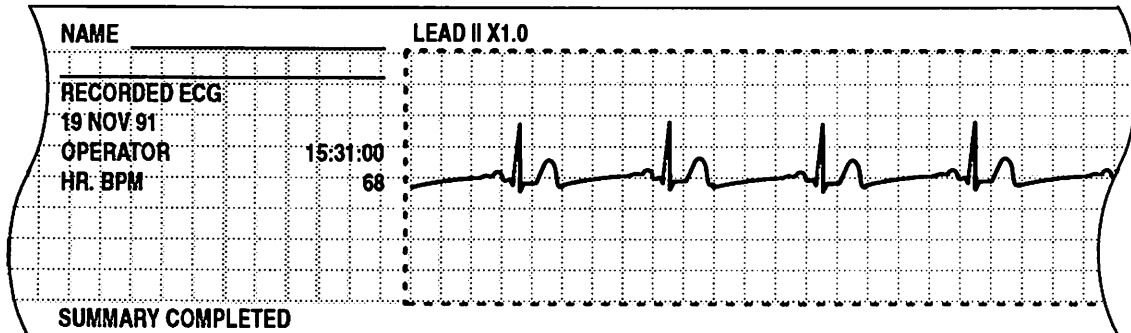
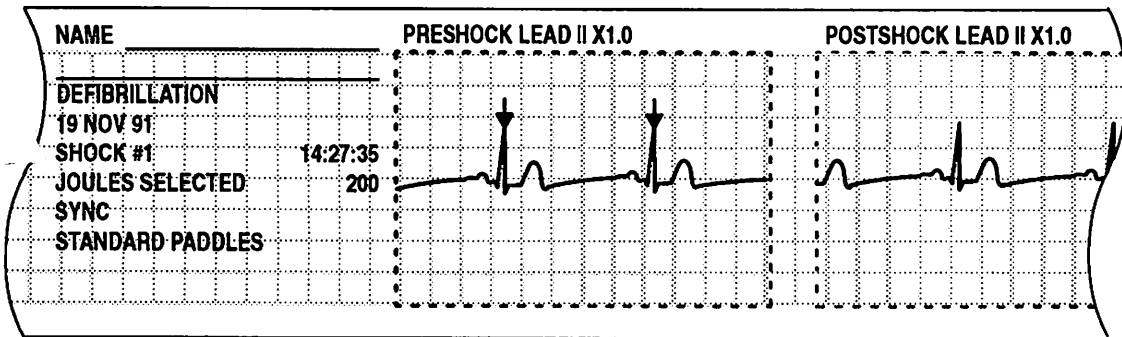


Figure 3-6 Example of CODE SUMMARY Printout



### PIP-Leakage Current

Check leakage current in accordance with the following standards: AAMI/ANSI (Association for the Advancement of Medical Instrumentation/ American National Standards Institute) ES1-1985, AAMI/ANSI DF2-1989, CSA (Canadian Standards Association) C22.2, IEC (International Electrotechnical Commission) 601-1, IEC 601-2-4, and UL (Underwriters Laboratories) 544.

Because of the wide variety of Safety Analyzers that may be used for these tests, specific instructions are not provided in this PIP. Refer to your Safety Analyzer operator's manual for instructions about configuring and performing these tests. The maximum allowable leakage current is summarized in Table 3-3 for 120Vac, 60Hz, and in Table 3-4 for 230Vac, 50Hz. When measuring ground resistance for the leakage current tests, connect the ohmmeter between the rear panel ground stud and the ground pin on the ac power connector as shown in Figure 3-7.

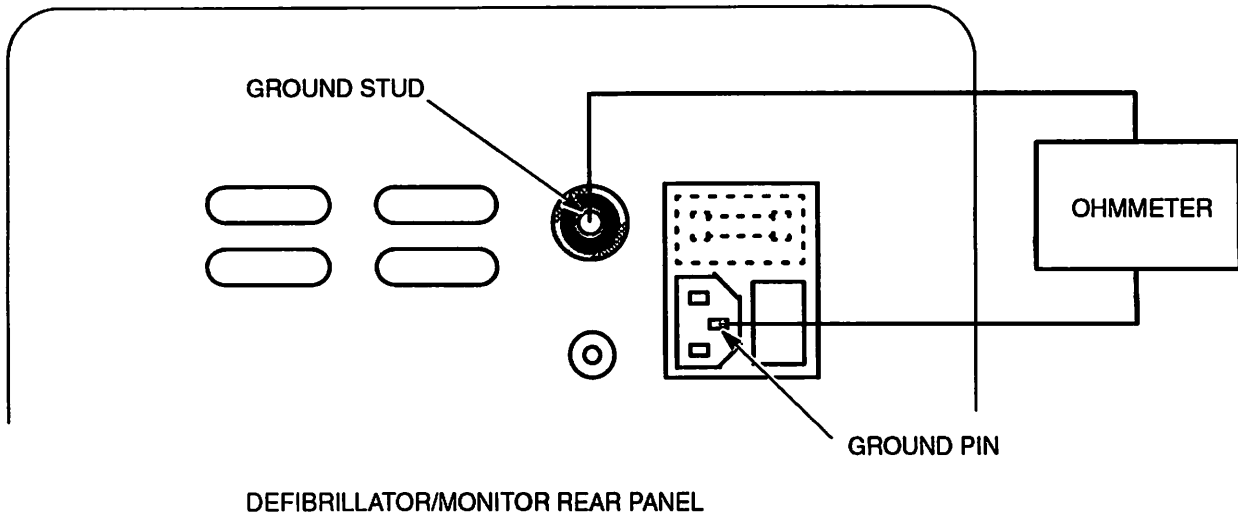


Figure 3-7 Test Connections for Ground Resistance Measurement

### Warning

**ELECTRICAL HAZARD.** Make sure you are familiar with your test equipment and how to execute these tests. Failure to properly perform these tests could result in not detecting excessive leakage current.

**Table 3-3 Maximum Leakage Current for 120Vac and 60Hz**

Parameter	Closed Safety Ground SOURCE ( $\mu\text{A}$ )	Open Safety Ground SOURCE ( $\mu\text{A}$ )	Closed Safety Ground SINK ( $\mu\text{A}$ )
Chassis to Ground	$\leq 69$	$\leq 69$	N/A
ECG Shorted All Leads	$\leq 9.0$	$\leq 9.0$	$\leq 19$
Interlead RA-LA	$\leq 9.0$	$\leq 9.0$	$\leq 19$
Interlead RA-RL	$\leq 9.0$	$\leq 9.0$	$\leq 19$
Interlead LA-RL	$\leq 9.0$	$\leq 9.0$	$\leq 19$
Paddles, Shorted	$\leq 69$	$\leq 69$	$\leq 69$
Paddles, Paired	$\leq 69$	$\leq 69$	N/A

- NOTE: 1. All tests are conducted in both hot/neutral normal and reverse polarities.  
 2. Test procedure limits based on AAMI/ANSI Standards with meter inaccuracies factored in.  
 3. N/A = Not Applicable.  
 4. Ground resistance:  $<0.050\Omega$  as measured between the rear panel ground stud and the ground pin on the ac power connector (refer to Figure 3-7).

**Table 3-4 Maximum Leakage Current for 230Vac and 50Hz**

Parameter	Closed Safety Ground SOURCE ( $\mu\text{A}$ )	Open Safety Ground SOURCE ( $\mu\text{A}$ )	Closed Safety Ground SINK ( $\mu\text{A}$ )
Chassis to Ground	$\leq 73$	$10 \leq i^* \leq 123$	N/A
ECG Shorted All Leads	$\leq 6.4$	$\leq 24$	$\leq 24$
Interlead RA-LA	$\leq 8.5$	$\leq 18$	$\leq 18$
Interlead RA-RL	$\leq 8.5$	$\leq 18$	$\leq 18$
Interlead LA-RL	$\leq 8.5$	$\leq 18$	$\leq 18$
Paddles, Shorted	$\leq 24$	$\leq 24$	$\leq 384$
Paddles, Paired	$\leq 18$	$\leq 18$	N/A

- NOTE: 1. All tests are conducted in both hot/neutral normal and reverse polarities.  
 2. Test procedure limits based on IEC Standards with meter inaccuracies factored in.  
 3. N/A = Not Applicable.  
 4. Ground resistance:  $<0.100\Omega$  as measured between the rear panel ground stud and the ground pin on the ac power connector (refer to Figure 3-7).

\*  $i$  = measured current.

**Note:** After completing the PIP, be sure to restore the Setup Menu option settings required by the user during normal operation (these settings were noted when you performed PIP-Setup Menu Settings on page 3-5).

## PIP Checklist

Customer: \_\_\_\_\_ Date: \_\_\_\_\_  
 Dept/Location: \_\_\_\_\_  
 Instrument Type: \_\_\_\_\_ Model: \_\_\_\_\_  
 Serial Number: \_\_\_\_\_  
 Frequency: \_\_\_\_\_ Last Insp: \_\_\_\_\_  
 Tech. Name/ID: \_\_\_\_\_

Performance Inspection	Pass	Fail	Comments
Physical Inspection	<input type="checkbox"/>	<input type="checkbox"/>	_____
AC Power	<input type="checkbox"/>	<input type="checkbox"/>	_____
Battery Charge	<input type="checkbox"/>	<input type="checkbox"/>	_____
Battery Power	<input type="checkbox"/>	<input type="checkbox"/>	_____
Setup Menu Settings			User settings for normal operation (circle or fill blank): LANGUAGE:        ENG FRE GER SPA ENG POR ITA SWE RECORDER:        MON or DIAG NOTCH:            50HZ or 60HZ LEADS NOTCH:    NO or YES LEAD:             LEAD II or PADDLES HR LIMITS:        150 ___ 120 ___ 160 ___ 040 ___ 060 ___ 090 ___ ALARM VOLUME:   1 2 3 4 5 6 7 8
Keypad Test	<input type="checkbox"/>	<input type="checkbox"/>	_____
Lead Select	<input type="checkbox"/>	<input type="checkbox"/>	_____
Recorder Speed/Baseline Centering	<input type="checkbox"/>	<input type="checkbox"/>	_____
ECG Display	<input type="checkbox"/>	<input type="checkbox"/>	_____
1mV CAL	<input type="checkbox"/>	<input type="checkbox"/>	_____
CRT Gain/Aspect Ratio	<input type="checkbox"/>	<input type="checkbox"/>	_____
Heart Rate	<input type="checkbox"/>	<input type="checkbox"/>	_____
Rate Alarms/Alarm-Activated Record	<input type="checkbox"/>	<input type="checkbox"/>	_____
Recorder Annotation/Real-Time Clock	<input type="checkbox"/>	<input type="checkbox"/>	_____
Test Load	<input type="checkbox"/>	<input type="checkbox"/>	_____
Sync/Sync Annotation	<input type="checkbox"/>	<input type="checkbox"/>	_____
Recorder/CRT Noise	<input type="checkbox"/>	<input type="checkbox"/>	_____
Defib Disarm and CHARGE LEDs Check	<input type="checkbox"/>	<input type="checkbox"/>	_____
Paddle Polarity	<input type="checkbox"/>	<input type="checkbox"/>	_____
Charge Time	<input type="checkbox"/>	<input type="checkbox"/>	_____

Performance Inspection (Cont.)	Pass	Fail	Comments
Discharge Control	<input type="checkbox"/>	<input type="checkbox"/>	
Energy Dump	<input type="checkbox"/>	<input type="checkbox"/>	
Charge Reduction	<input type="checkbox"/>	<input type="checkbox"/>	
Delivered Energy	<input type="checkbox"/>	<input type="checkbox"/>	
CODE SUMMARY Report	<input type="checkbox"/>	<input type="checkbox"/>	
Leakage Current (see below)	<input type="checkbox"/>	<input type="checkbox"/>	
Restore user Setup Menu settings	<input type="checkbox"/>	<input type="checkbox"/>	

### Maximum Leakage Current for 120Vac and 60Hz

Parameter	Closed Safety Ground SOURCE ( $\mu\text{A}$ )		Open Safety Ground SOURCE ( $\mu\text{A}$ )		Closed Safety Ground SINK ( $\mu\text{A}$ )	
	Limit	Actual	Limit	Actual	Limit	Actual
Chassis to Ground	$\leq 69$		$\leq 69$		N/A	
ECG Shorted, All Leads	$\leq 9.0$		$\leq 9.0$		$\leq 19$	
Interlead RA-LA	$\leq 9.0$		$\leq 9.0$		$\leq 19$	
Interlead RA-RL	$\leq 9.0$		$\leq 9.0$		$\leq 19$	
Interlead LA-RL	$\leq 9.0$		$\leq 9.0$		$\leq 19$	
Paddles, Shorted	$\leq 69$		$\leq 69$		$\leq 69$	
Paddles, Paired	$\leq 69$		$\leq 69$		N/A	

- NOTE: 1. All tests are conducted in both hot/neutral normal and reverse polarities.  
 2. Test procedure limits based on AAMI/ANSI Standards with meter inaccuracies factored in.  
 3. N/A = Not Applicable.  
 4. Ground resistance:  $<0.050\Omega$  as measured between the rear panel ground stud and the ground pin on the ac power connector (refer to Figure 3-7).

### Maximum Leakage Current for 230Vac and 50Hz

Parameter	Closed Safety Ground SOURCE ( $\mu\text{A}$ )		Open Safety Ground SOURCE ( $\mu\text{A}$ )		Closed Safety Ground SINK ( $\mu\text{A}$ )	
	Limit	Actual	Limit	Actual	Limit	Actual
Chassis to Ground	$\leq 73$		$10 \leq i^* \leq 123$		N/A	
ECG Shorted, All Leads	$\leq 6.4$		$\leq 24$		$\leq 24$	
Interlead RA-LA	$\leq 8.5$		$\leq 18$		$\leq 18$	
Interlead RA-RL	$\leq 8.5$		$\leq 18$		$\leq 18$	
Interlead LA-RL	$\leq 8.5$		$\leq 18$		$\leq 18$	
Paddles, Shorted	$\leq 24$		$\leq 24$		$\leq 384$	
Paddles, Paired	$\leq 18$		$\leq 18$		N/A	

- NOTE: 1. All tests are conducted in both hot/neutral normal and reverse polarities.  
 2. Test procedure limits based on IEC Standards with meter inaccuracies factored in.  
 3. N/A = Not Applicable.  
 4. Ground resistance:  $<0.100\Omega$  as measured between the rear panel ground stud and the ground pin on the ac power connector (refer to Figure 3-7).  
 \* i = measured current.

## Test and Calibration Procedure (TCP)

The Test and Calibration Procedure (TCP) contains in-depth testing and calibration instructions for the LIFEPAK 9 defibrillator/monitor. Unlike the PIP (Performance Inspection Procedure), only those tests considered necessary need to be performed, and these may be conducted in any order. It is necessary to separate the case halves for some of the tests.

### TCP-Purpose

These tests may be performed if the defibrillator/monitor fails a step in the PIP or if there is a suspected failure in an assembly. Perform the PIP after completing any of the tests in this section.

**Note:** *If you perform any of the tests in this TCP, perform the PIP (page 3-1) afterward to confirm that the defibrillator/monitor is performing within specifications.*

### TCP-Scope and Applicability

This TCP applies to the LIFEPAK 9 defibrillator/monitor. This PIP does *not* apply to the LIFEPAK 9A, LIFEPAK 9B, or LIFEPAK 9P defibrillator/monitors; refer to their respective service manuals for testing information.

### TCP-Definitions

DMM	Digital Multimeter
ECG	Electrocardiogram
ESD	Electrical Static Discharge
NSR	Normal Sinus Rhythm
PIP	Performance Inspection Procedure
p-p	peak-to-peak
QRS or QRS Complex	Refers to portions of the ECG waveform
SSD	Static-Sensitive Device
TCP	Test and Calibration Procedure

### TCP-Requirements

The following are *minimum* requirements:

#### TCP-Equipment Requirements

Test equipment required for maintenance and calibration of the LIFEPAK 9 defibrillator/monitor is listed in Table 3-5. Although specific test equipment is recommended, other test equipment with equivalent specifications may be used.

Table 3–5 Test and Calibration Test Equipment

Equipment	Specifications	Manufacturer
Storage Oscilloscope	Bandwidth: dc to 2kHz Vertical Accuracy: $\pm 5\%$ (5mV-5V/division) Horizontal Time Base Accuracy: $\pm 1\%$	Tektronix Model 2232 or equivalent*
Digital Multimeter (DMM)	4-1/2 digits, 2A Range DC Voltage Accuracy: 0.1% of reading Low Resistance: 0.01 $\Omega$ resolution on 200 $\Omega$ scale	Fluke Model 8012A or equivalent*
Function Generator	Output Waveform: Sinusoidal Amplitude/Freq. Accuracy: $\pm 0.5\text{dB}/\pm 5\%$ Amplitude/Freq. Range: 10V/11MHz	Krohn-Hite Model 5400A or equivalent*
ECG Simulator	Sinewave Output: 1.0 $\pm$ 0.5mV p-p Output Frequency: 10.0 $\pm$ 0.5Hz	Bio-Tek QED-6 or equivalent*
Defibrillator Energy Meter	Power Range: 0-400J Load Resistance: 50 $\Omega$ $\pm$ 1% Accuracy: $\pm 3\%$ Defib Waveform Amplitude Attenuation: 1000:1 (min.) with oscilloscope output	Bio-Tek QED-6 or equivalent*
DC Power Supply	Output Voltage: 0 to 20Vdc Output Current: 0 to 3A	Topward Model TPS 2000 or equivalent*
Timer	Resolution: 1 second	Aristo or equivalent*
Components for Recorder Frequency Response test (construction defined in Figure 3–14, page 3–36)	R1, R2 Resistor, 100k $\Omega$ , 1/8W, 1% R3, R4 Resistor, 100 $\Omega$ , 1/8W, 1%	Physio-Control PN 200054-384 Physio-Control PN 200054-097
Phone plug	0.25 inch plug tip	

\* Equivalent equipment is required to meet the specifications listed in the specifications column.

## TCP-Test Equipment Verification

All test equipment used in performing the TCP must have a current calibration label affixed to its exterior. The calibration label must be issued by a certified calibration facility.

## TCP-Workstation Requirements

Workstations where the TCP is performed must provide an Electrical Static Discharge (ESD) protected environment. The ac line power for this workstation must be connected to a grounded power source.

## TCP-Personnel

Personnel performing this TCP must be thoroughly familiar with the operation of the LIFEPAK 9 defibrillator/monitor. In addition, personnel performing this TCP must meet at least one of the following levels of education or experience:

- Associate of applied science degree with a major emphasis in biomedical electronics
- Certificate of technical training in electronics with a major emphasis in biomedical electronics
- Equivalent biomedical electronics experience.

**Warning**

**SHOCK HAZARD.** Terminals and wires carrying high voltages up to +11.6kV are exposed with the defibrillator/monitor cases removed. Do not touch internal circuitry except as indicated in these procedures.

**Warning**

**SHOCK HAZARD.** When charged and discharged during this TCP, the LIFEPAK 9 defibrillator/monitor discharges up to 360J of electrical energy through the defibrillator paddles. Unless discharged properly as described in this TCP, this electrical energy may cause injury or death. Do not attempt to perform this procedure unless you are thoroughly familiar with the operation of the LIFEPAK 9 defibrillator/monitor.

**Warning**

**POSSIBLE ARCING AND PADDLE DAMAGE.** When discharging the defibrillator into the internal test load, make sure the standard paddles are securely and properly stored in the paddle storage area (STERNUM paddle on the left, APEX paddle on the right). This helps prevent arcing and formation of pits on paddle electrode surfaces. Pitted or damaged paddle electrode surfaces can cause patient skin burns during defibrillation.

**Caution**

**Possible Component Damage.** Static Sensitive Devices (SSDs) require special handling. Follow the special handling procedures described on page 4-5 to prevent static discharge and damage. Refer to Table 5-1 to identify PCB assemblies containing SSDs.

**TCP-Voltage Checks**

1. With the defibrillator/monitor power off, remove the front panel to access the test connector J3 on the Power Conversion PCB (leave the front panel connector cable connected). For disassembly instructions, refer to page 4-7, Front Panel Removal.
2. Connect the ground lead of the DMM to pin 7 of J3. Refer to Figure 3-8.
3. Turn the defibrillator/monitor power on and check that the voltages are within the limits listed in Table 3-6.

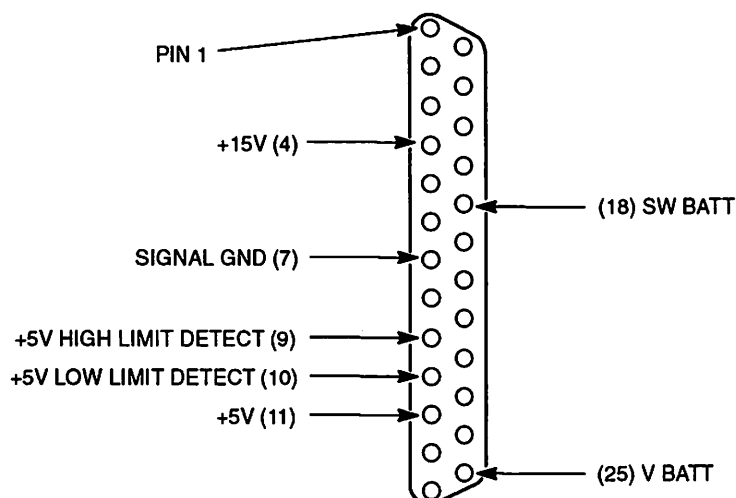


Figure 3–8 Test Connector J3

Table 3–6 Power Conversion PCB Voltage Checks

Test Point	Signal Name	Nominal Voltage	Limits
Pin 4	+15V	+15.0V	±0.3V
Pin 11	+5V	+5.00V	±0.25V
Pin 9	+5V High Limit Detect	+2.25V	±0.15V
Pin 10	+5V Low Limit Detect	+2.625V	±0.125V
Pin 18	SW BATT	+18.0V	+2.0V to –2.4V
Pin 25	V BATT	+18.4V	+1.6V to –2.8V

### TCP–Low Battery Threshold Checks

1. With the defibrillator/monitor power off, remove the front panel to access the test connector J3 on the Power Conversion PCB (leave the front panel connector cable connected). For disassembly instructions, refer to page 4–7, Front Panel Removal.
2. Remove the battery door on the bottom of the defibrillator/monitor and disconnect the battery. Connect the DC power supply to the battery connector inputs. Connect ground to pin 1 or 2 (black wire) and power to pin 3 or 4 (red wire).

### Monitoring Check

1. Use the DMM to monitor the voltage at the J3 pin 25 as shown in Figure 3–8 (connect the DMM ground to J3 pin 7).
2. Turn the defibrillator/monitor power on and initially set the power supply output to +18.00 ±0.05Vdc.
3. Slowly decrease the output voltage until the monitor displays the message **LOW BATTERY: CONNECT AC POWER** (decrease the power supply voltage quickly enough to cause the message to appear within 45 seconds or less). Confirm that the power supply voltage level is within the Low Battery Limits listed for the Monitoring Check in Table 3–7.



**Table 3-7 Low Battery Thresholds**

Test Point	Function	Low Battery Limits	Shutdown Limits
Pin 25	Monitoring Check	15.50V $\pm$ 0.23V	14.50V $\pm$ 0.21V
Pin 25	Defib Charge Check	15.00V $\pm$ 0.22V	13.50V $\pm$ 0.20V

*Note:* Once illuminated, the **LOW BATTERY: CONNECT AC POWER** message will not reset until the battery voltage rises above 16.5V.

## Defibrillator Charge Check

4. Return the power supply voltage to +18.00  $\pm$ 0.05Vdc. Slowly reduce the power supply voltage until the CRT display blanks out. Confirm that the power supply voltage is within the Shutdown Limits shown in Table 3-7 for the Monitoring Check.
1. Use the DMM to monitor the voltage at the J3 pin 25 as shown in Figure 3-8 (connect the DMM ground to J3 pin 7).
  2. Turn the defibrillator/monitor power on and initially set the power supply output to +18.00  $\pm$ 0.05Vdc.
  3. Charge the defibrillator to 360J.
  4. Gradually reduce the power supply voltage toward the upper Low Battery Limit detection threshold of +15.22Vdc.
  5. With the defibrillator paddles securely stored in the paddle wells, discharge the defibrillator into the internal test load of the defibrillator.
  6. Repeat steps 3 through 5 above, lowering the power supply voltage toward the lower Low Battery Limit detection threshold of +14.78Vdc until the **LOW BATTERY: CONNECT AC POWER** message is displayed. Confirm that the triggering voltage is within the Low Battery Limits shown in Table 3-7 for the Defib Charge Check.
  7. Return the power supply voltage to +18.00  $\pm$ 0.05Vdc.
  8. Charge the defibrillator to 360J.
  9. Slowly reduce the power supply voltage toward the upper Shutdown Limit detection threshold of +13.70Vdc.
  10. Discharge the defibrillator into the internal test load of the defibrillator.
  11. Repeat steps 8 through 10 above, lowering the power supply voltage toward the lower Shutdown Limit of +13.30Vdc until the CRT display blanks out. Confirm that the power supply voltage is within the Shutdown Limits shown in Table 3-7 for the Defib Charge Check.

## TCP–Test Menu Access

Three of the four tests on the Test Menu (**DEFIB**, **DISPLAY**, and **RECORDER**) are used in Test and Calibration Procedures. To access the Test Menu, do the following:

1. Turn the defibrillator/monitor power off.
2. Press ON while pressing and holding down LEAD SELECT and HR ALARM until the Test Menu is displayed as shown in Figure 3–9.

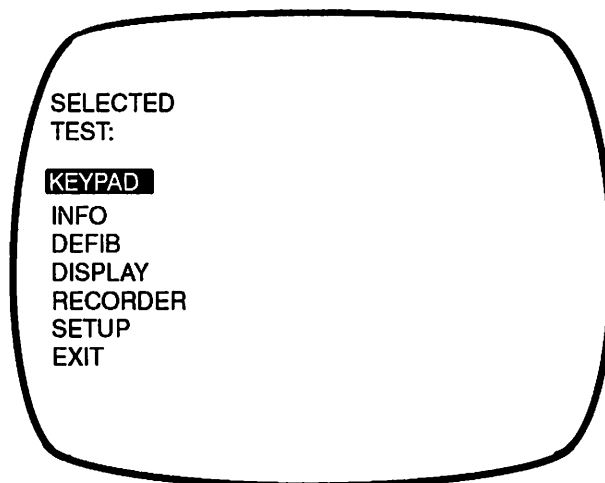


Figure 3–9 Test Menu

- Press ▼ ECG SIZE ▲ to scroll through the selections.
- Press HR ALARM to start a test.
- Press LEAD SELECT to interrupt a test in progress and return to the Test Menu.
- To exit the test menu, press ▼ ECG SIZE ▲ to scroll to EXIT, then press HR ALARM.

## TCP–Defibrillator Calibration

1. With the defibrillator/monitor power off, place the paddles on the energy meter electrodes.

### Caution

**Possible Energy Meter Damage.** Start each test at the lowest energy level to avoid overheating the energy meter. Test each energy level in successive order.

2. Access the Test Menu (turn power off, then press ON while pressing and holding down LEAD SELECT and HR ALARM until the Test Menu is displayed).

3. Press ▼ ECG SIZE ▲ to scroll to the **DEFIB** test.
4. Press **HR ALARM** to start the **DEFIB** test.
5. Press ▼ **ENERGY SELECT** ▲ to scroll to **LOW**. Select 1J.
6. Press **CHARGE**.
7. After the defibrillator/monitor reaches full charge as indicated by the tone, simultaneously press both paddle discharge pushbuttons to transfer the energy into the energy meter.
8. Confirm that the CRT displays the message **JOULES DELIVERED: XXX**, where **XXX** is the energy selected.
9. Read the value on the energy meter.
10. Press ▼ **ECG SIZE** ▲ as necessary to change the **JOULES DELIVERED: XXX** value to match the value on the energy meter.
11. Press **HR ALARM** to enter the adjusted value.
12. Press **CHARGE**. After charging is complete, simultaneously press both paddle discharge pushbuttons to transfer the energy into the energy meter. Confirm that the energy meter value equals the selected value as indicated in Table 3–8.

**Table 3–8 Defibrillator Calibration Measurement Ranges**

Selected Value (J)	Acceptable Range		Selected Value (J)	Acceptable Range	
	Value (J)	% Tolerance		Value (J)	% Tolerance
1	0.8 to 1.2	±20%	20	19.0 to 21.0	±5%
2	1.8 to 2.2	±10%	30	28.5 to 31.5	±5%
3	2.7 to 3.3	±10%	50	47.5 to 52.5	±5%
4	3.8 to 4.2	±5%	100	95.0 to 105.0	±5%
5	4.8 to 5.2	±5%	200	190.0 to 210.0	±5%
6	5.7 to 6.3	±5%	300	285.0 to 315.0	±5%
7	6.7 to 7.3	±5%	360	342.0 to 378.0	±5%
8	7.6 to 8.4	±5%			
9	8.6 to 9.4	±5%			
10	9.5 to 10.5	±5%			

13. Press **HR ALARM** to reinitiate the **DEFIB** test.
14. Repeat steps 5 through 13 for each energy level.
15. Return the paddles to the paddle storage area on the defibrillator.

## TCP-Test Load Calibration

**Note:** Complete TCP-Defibrillator Calibration before performing this calibration of the test load.

1. Make sure the paddles are securely stored in the paddle storage area of the defibrillator.
2. Access the Test Menu (turn power off, then press ON while pressing and holding down LEAD SELECT and HR ALARM until the Test Menu is displayed).
3. Press ▼ ECG SIZE ▲ to scroll to the **DEFIB** test.
4. Press HR ALARM to start the **DEFIB** test.
5. Press ▼ ENERGY SELECT ▲ to set the selected energy to 200J.
6. Press CHARGE.
7. After the defibrillator reaches full charge, simultaneously press the paddle discharge pushbuttons to transfer the energy into the test load.
8. When the CRT displays **JOULES DELIVERED: 200**, press HR ALARM.
9. Press LEAD SELECT to return to the Test Menu.
10. Scroll to **EXIT** and press HR ALARM to resume normal operation. Select **STD** lead.
11. Press CHARGE. After the defibrillator reaches full charge, simultaneously press the paddle discharge pushbuttons to transfer the energy into the test load.
12. Confirm that the CRT displays **TEST 200 JOULES DELIVERED**.
13. Confirm that the recorder prints the time and date followed by **TEST 200 JOULES DELIVERED**.

### TCP-Charge Time

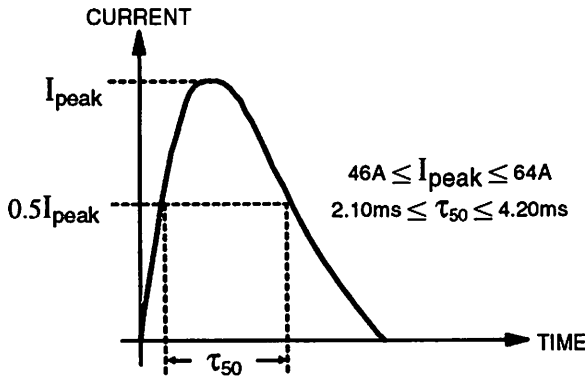
1. Make sure the paddles are securely stored in the paddle storage area of the defibrillator.
2. Press ▼ ENERGY SELECT ▲ to set the selected energy to 360J.
3. Simultaneously start the timer and press CHARGE.
4. Stop the timer when the defibrillator reaches full charge. Confirm that the time required to reach full charge is less than 10 seconds.
5. Simultaneously press both paddle discharge pushbuttons to transfer the energy into the test load.

### TCP-Output Waveform

1. Place the paddles on the energy meter electrodes. Place the APEX paddle on the right electrode of the energy meter so that the pulse polarity is positive.
2. Connect the storage oscilloscope to the energy meter signal output.
3. Set up the oscilloscope for the "single shot" acquisition mode for the pulse waveform capture. Refer to the Operating Instructions for the oscilloscope for assistance. For waveform parameter measurement, place both the left and right measurement markers at both the 50% and 10% levels.
4. Press ▼ ENERGY SELECT ▲ to select 360J.
5. Press CHARGE.
6. After the defibrillator reaches full charge, simultaneously press the paddle discharge pushbuttons to transfer the energy into the energy meter.
7. Inspect the waveform displayed on the oscilloscope and confirm that the waveform meets the specifications listed below and illustrated in Figure 3-10.

Peak current = 46A to 64A peak  
Time above 50% = 2.10ms to 4.20ms  
Time above 10% = 3.10ms to 9.20ms

PEAK CURRENT – TIME ABOVE 50%



PEAK CURRENT – TIME ABOVE 10%

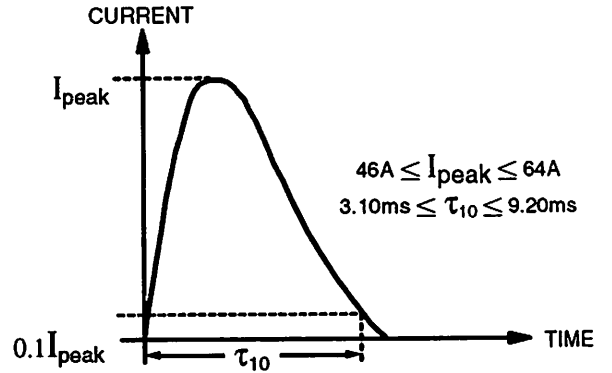


Figure 3-10 Output Waveform

TCP-Display Calibration

The following paragraphs describe the calibration procedure for the Display Assembly PCB. Figure 3-11 shows the location of all Display Assembly PCB potentiometers.

1. Disconnect the ac power cord. Remove front and rear cases to allow access to the potentiometers. For disassembly instructions, refer to page 4-8, Case Separation.

**Warning**

**SHOCK HAZARD.** The Display Assembly produces high voltages up to +11.6kV. Do not contact the CRT anode connector or the CRT bias generator circuitry when the defibrillator/monitor power is on.

**Warning**

**FLYING GLASS HAZARD.** The CRT is made of glass and contains a vacuum which may implode if broken. Handle with care and wear safety glasses when removing the CRT from the Display Assembly PCB.

2. Reconnect the ac input cord. Reconnect J1 on the front panel.

**Note:** Reroute J1 ribbon cable underneath C32 on the Power Conversion PCB to prevent strain on the capacitor during the following tests.

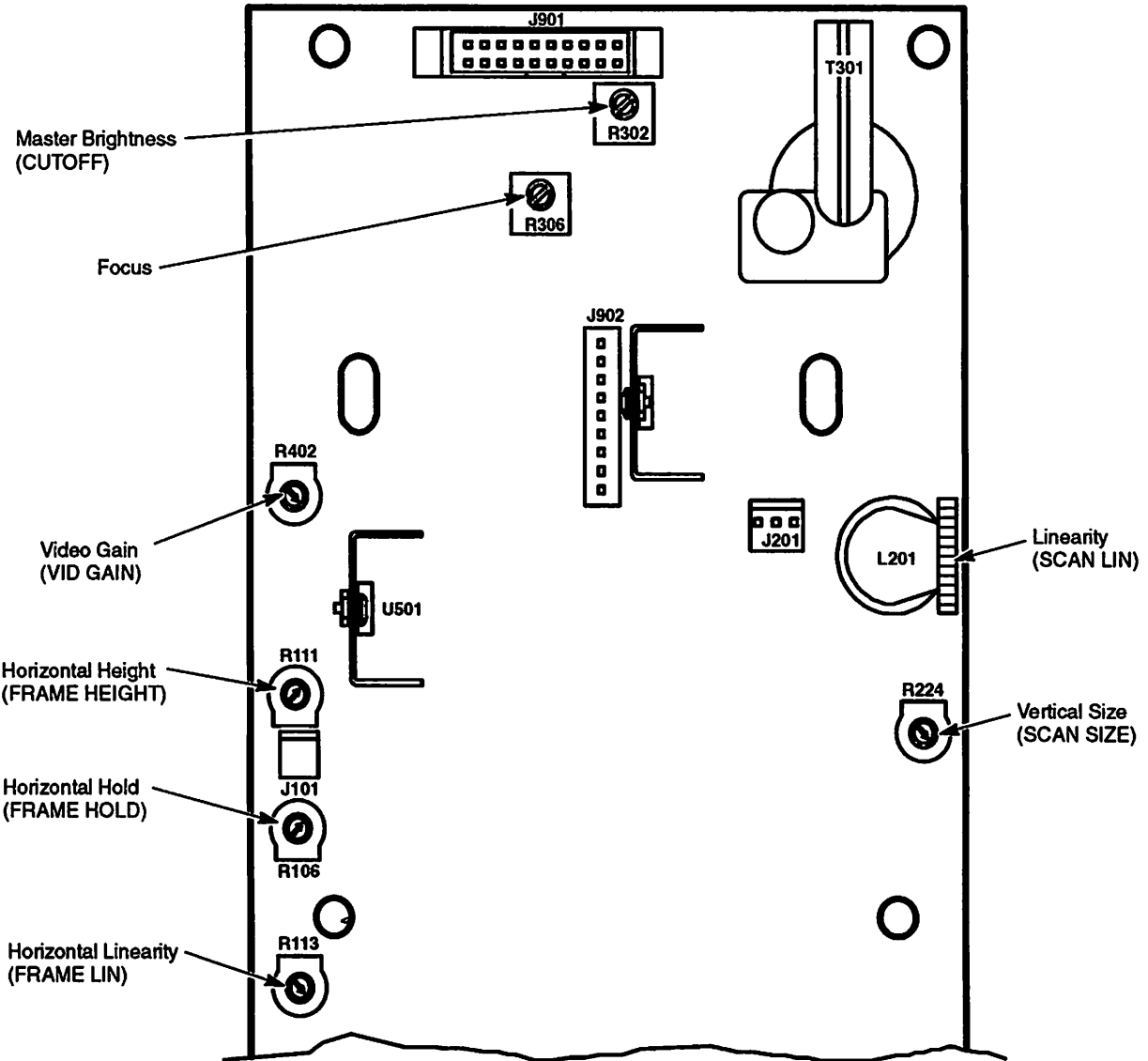


Figure 3-11 Display PCB Assembly Potentiometer Locations

**Warning**

**SHOCK HAZARD.** High voltages up to 1000V may be present on the leads of R302 and R306. Use an insulated screwdriver for adjustment.

3. Press ON. Adjust R302, Master Brightness (CUTOFF), until the vertical raster lines are visible behind the characters.
4. Turn R106, Horizontal Hold (FRAME HOLD), approximately 1/8 turn past the point where the horizontal rolling stops.
5. Access the Test Menu (turn power off, then press ON while pressing and holding down LEAD SELECT and HR ALARM until the Test Menu is displayed).
6. Press ▼ ECG SIZE ▲ to scroll to the **DISPLAY** test, then press HR ALARM to start the test.
7. Press ▼ ECG SIZE ▲ to select the **PATTERN** test.
8. Adjust: R224, Vertical Size (SCAN SIZE); L201, Linearity (SCAN LIN); and R111, Horizontal Height (FRAME HEIGHT), to obtain a display pattern that fills most of the screen.
9. Loosen the screw holding the yoke clamp.
10. Rotate the yoke until the display pattern is level.
11. Tighten the screw on the yoke clamp and confirm that the display pattern is still level.
12. Adjust the yoke rings to center the display pattern on the CRT.
13. Adjust R224 for a display pattern grid height of  $73 \pm 2\text{mm}$ . Adjust L201 to make each box of the display pattern approximately the same height.

**Note:** *The adjustments of R224 and L201 are interactive. Repeat the preceding step until both measurements are correct.*

14. Turn R402, Video Gain (VID GAIN), fully counterclockwise.
15. Turn the defibrillator/monitor off and allow the CRT to cool down for approximately 10 minutes. Then, access the Test Menu and select the **DISPLAY: PATTERN** test.



**Warning**

**SHOCK HAZARD.** Potentially dangerous voltages are present on the pins of R302 and R306. Use an insulated screwdriver for adjustment.

16. Turn R302 counterclockwise just until the raster disappears. Turn R302 counterclockwise approximately 1/16 turn more.
17. Turn R402 clockwise until the normal display intensity is visible.

*Note: Raster will not reach normal intensity if R302 is turned too far counterclockwise.*

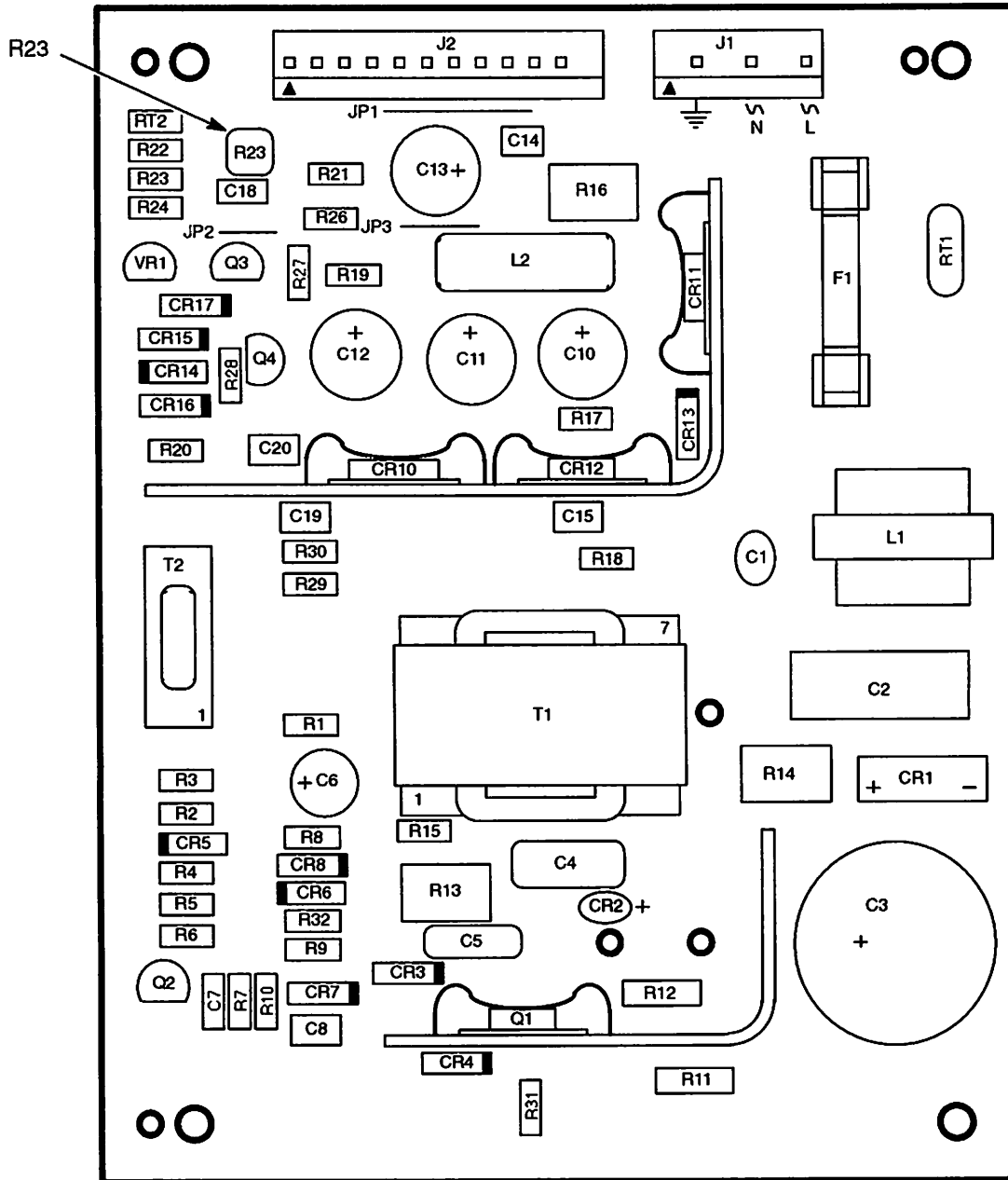
18. Adjust R111 for an overall pattern width of  $106 \pm 2$ mm. Adjust R113, Horizontal Linearity (FRAME LIN) so that each box is approximately the same width.

*Note: The adjustments of R111 and R113 are interactive. Repeat the above step until both measurements are correct.*

19. Adjust R402 to obtain a dim display. Adjust R306, Focus, for maximum sharpness of the display characters.
20. Adjust the yoke rings to center the test pattern on the CRT within 2mm. Confirm that the difference in height from the right side to the left side of the test pattern is less than or equal to 1mm. Check that the difference in width from the top to the bottom is less than or equal to 2mm.
21. Turn R402 clockwise until the normal display intensity is visible.

**TCP-Power Supply Calibration**

1. To gain access to R23 on the Power Supply PCB, first remove front and rear cases (for disassembly instructions, refer to page 4-8, Case Separation). Then remove the four screws holding the Power Supply PCB and pull it away from the chassis to access R23 as shown in Figure 3-12.



**Figure 3-12 Power Supply Calibration**

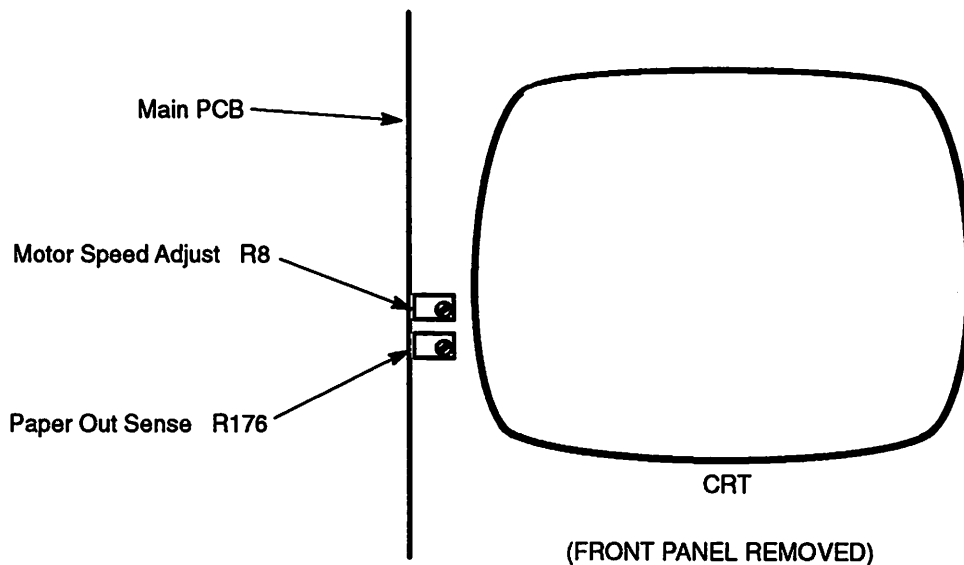
2. Reconnect the battery to the defibrillator/monitor.

**Note:** *The Power Supply compensates for temperature fluctuations. The defibrillator/monitor must be powered-on for at least 30 minutes prior to calibration so the temperature around thermistor RT2 stabilizes.*

3. Connect the DMM between the positive and negative battery terminals.
4. Connect the ac power cord and press ON.
5. Locate R23. Remove the potting compound from R23 as required to allow adjustment. Adjust R23 for  $+18.40 \pm 0.18V$ .

### TCP-Recorder Calibration

1. Remove the front panel. The two potentiometers (R176 and R8 on the Main PCB) required for Recorder Calibration are accessible with the front panel removed as shown in Figure 3-13.



**Figure 3-13 Recorder Calibration Adjustments Location**

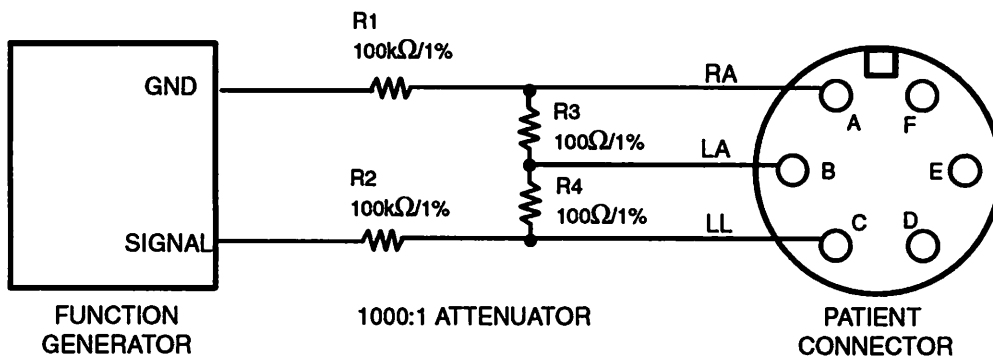
2. Access the Test Menu (turn power off, then press ON while pressing and holding down LEAD SELECT and HR ALARM until the Test Menu is displayed).
3. Press ▼ ECG SIZE ▲ to scroll to the **RECORDER** test, then press HR ALARM. Make sure the **RECORDER: PATTERN** test is selected.

*Note: During this calibration procedure the printhead dot intensity is decreased to prevent damage to the printhead and drive roller. Consequently, print legibility may range from light to invisible.*

4. Turn R176, Paper Out Sense, on the Main PCB fully clockwise.
5. Make sure paper is installed in the recorder and press RECORD. Confirm that the recorder does not print, or if it does print that the **NO PAPER** message is displayed.
6. Slowly turn R176 counterclockwise while repeatedly pressing RECORD. Adjust R176 just to the point where the recorder is on and the **NO PAPER** message is *not* displayed. This procedure may need to be repeated to determine this threshold.
7. Remove the paper from the recorder and close the recorder doors.
8. Counting the number of rotations required, turn R176 counterclockwise while repeatedly pressing RECORD. Adjust R176 just to the point where the recorder turns on. Note the number of rotations required to make the adjustment.
9. Adjust R176 to the midpoint of the number of rotations between steps 6 and 8.
10. Confirm that the recorder only operates when paper is loaded.
11. Press ▼ ECG SIZE ▲ to select the **RECORDER: MOTOR SPEED** test.
12. Press RECORD. Inspect the printout and confirm that the period of the printed sawtooth waveform is  $25 \pm 1$ mm. Adjust R8, Motor Speed Adjust, if necessary to obtain the period of  $25 \pm 1$ mm. Press RECORD to turn off the recorder.
13. Reinstall the front panel.

## TCP-Recorder Frequency Response

1. Access the Test Menu (turn power off, then press ON while pressing and holding down LEAD SELECT and HR ALARM until the Test Menu is displayed).
2. Press ▼ ECG SIZE ▲ to scroll to **SETUP**, then press HR ALARM to display the Setup Menu. Make sure **RECORDER** is set to **DIAG** and **LEADS NOTCH** is set to **NO** (if making any changes, press HR ALARM at the end to enter the option changes).
3. Press LEAD SELECT to return to the Test Menu, press ▼ ECG SIZE to scroll to **EXIT**, then press HR ALARM to resume normal operation.
4. Press LEAD SELECT to set the defibrillator/monitor to **LEAD II**. Press ▼ ECG SIZE ▲ as needed to select X1.0 gain.
5. Connect the function generator to the patient cable input using the test signal setup shown in Figure 3–14.



**Figure 3–14 Test Signal Setup for Function Generator**

6. Set the function generator for a 1V p-p, 10Hz sinewave. Press RECORD to turn on the recorder.

**Note:** Because the ECG trace on the recorder printout lags behind the signal input by approximately 10 seconds, the recorder must run for approximately 10 seconds before a change to the input signal appears on the printout.

7. Set the function generator to 0.05Hz. After 15 seconds, examine the printout and confirm that the recorded trace is between 7mm p-p and 10.5mm p-p.

8. Set the function generator to 0.5Hz. After 15 seconds, examine the printout and confirm that the recorded trace is between 9mm p-p and 10.5mm p-p.
9. Set the function generator to 60Hz. After 15 seconds, examine the printout and confirm that the recorded trace is between 7mm p-p and 10.5mm p-p.
10. Set the function generator to 100Hz. After 15 seconds, examine the printout and confirm that the recorded trace is between 7mm p-p and 10.5mm p-p.
11. Set the function generator to 110Hz. After 15 seconds, examine the printout and confirm that the recorded trace is less than 7mm p-p.
12. Access the Test Menu and then the Setup Menu. Set the **LEADS NOTCH** to **YES**. Press HR ALARM to enter the option change.
13. Press LEAD SELECT to return to the Test Menu, press ▼ ECG SIZE to scroll to **EXIT**, then press HR ALARM to resume normal operation.
14. Press LEAD SELECT to select **LEAD II**. Set the function generator output to a 1Vp-p sine wave and match the input line frequency (50Hz or 60Hz).
15. Press RECORD. After 15 seconds, examine the printout and confirm that the recorded trace is less than 1mm p-p.
16. Access the Test Menu and then the Setup Menu. Set **RECORDER** to **MON** and set **LEADS NOTCH** to **NO**. Press HR ALARM to enter the option changes, then exit the Setup Menu and Test Menu.
17. Set the function generator for a 1Vp-p, 1Hz sine wave.
18. Press LEAD SELECT to select **LEAD II**. Press ▼ ECG SIZE ▲ to set the gain to X1.0.
19. Press RECORD. Wait 10 seconds, then slowly sweep the function generator frequency from 1Hz to 40Hz. Examine the printout and confirm the recorded trace is 7mm p-p minimum.

### TCP-CRT Frequency Response

1. Press ▼ ECG SIZE ▲ to increase the ECG gain to X1.4.
2. Connect the function generator to the patient cable through the 1000:1 divider (as illustrated in Figure 3-14 on page 3-36).
3. Set the function generator for a 1Vp-p, 10Hz sinewave.
4. Decrease the function generator signal frequency to 1Hz. Confirm that the trace displayed on the CRT is  $19 \pm 2$ mm p-p.
5. Increase the function generator signal frequency to 40Hz. Confirm that the trace displayed on the CRT is  $19 \pm 2$ mm p-p.
6. Disconnect the function generator.

### TCP-ECG Output (when applicable)

1. Press LEAD SELECT to select LEAD II.
2. Connect the function generator to the patient cable through the 1000:1 divider (as illustrated in Figure 3-14 on page 3-36).
3. Set the function generator for a 1Vp-p, 10Hz sinewave at the output of the 1000:1 divider.
4. Connect a 0.25-inch phone plug to the ECG output on the rear panel of the defibrillator/monitor. Connect the oscilloscope to the phone plug.
5. Press ▼ ECG SIZE ▲ to set the gain to X1.0.
6. Confirm that the oscilloscope displays a  $1.00 \pm 0.15$ Vp-p sinewave.

# TCP Checklist

Customer: \_\_\_\_\_ Date: \_\_\_\_\_  
 Dept/Location: \_\_\_\_\_  
 Instrument Type: \_\_\_\_\_ Model: \_\_\_\_\_  
 Serial Number: \_\_\_\_\_  
 Frequency: \_\_\_\_\_ Last Insp: \_\_\_\_\_  
 Tech. Name/ID: \_\_\_\_\_

Test and Calibration	Pass	Fail	Comments
----------------------	------	------	----------

Voltage Checks   \_\_\_\_\_

**Low Battery Threshold Checks**

Monitoring Check   \_\_\_\_\_

Defib Charge Check   \_\_\_\_\_

**Test Menu Access**

Defibrillator Calibration   \_\_\_\_\_

Selected Value (J)	Acceptable Range		MEASURED VALUE (J)	Selected Value (J)	Acceptable Range		MEASURED VALUE (J)
	Value (J)	% Tolerance			Value (J)	% Tolerance	
1	0.8 to 1.2	±20%	_____	20	19.0 to 21.0	±5%	_____
2	1.8 to 2.2	±10%	_____	30	28.5 to 31.5	±5%	_____
3	2.7 to 3.3	±10%	_____	50	47.5 to 52.5	±5%	_____
4	3.8 to 4.2	±5%	_____	100	95.0 to 105.0	±5%	_____
5	4.8 to 5.2	±5%	_____	200	190.0 to 210.0	±5%	_____
6	5.7 to 6.3	±5%	_____	300	285.0 to 315.0	±5%	_____
7	6.7 to 7.3	±5%	_____	360	342.0 to 378.0	±5%	_____
8	7.6 to 8.4	±5%	_____				
9	8.6 to 9.4	±5%	_____				
10	9.5 to 10.5	±5%	_____				

Test Load Calibration   \_\_\_\_\_

Charge Time   \_\_\_\_\_

Output Waveform   \_\_\_\_\_

Display Calibration   \_\_\_\_\_

Power Supply Calibration   \_\_\_\_\_

Recorder Calibration   \_\_\_\_\_

Recorder Frequency Response   \_\_\_\_\_

CRT Frequency Response   \_\_\_\_\_

ECG Output   \_\_\_\_\_



## Troubleshooting Aids

The information in this section may help a service technician isolate possible software or circuit problems. It consists of the self-diagnostic error codes. If an instrument problem cannot be isolated and repaired, contact a Physio-Control customer service specialist in the US at 1-800-442-1142; outside the US, contact the local Physio-Control representative.

### Error Codes and SERVICE Indicator

The LIFEPAK 9 defibrillator/monitor contains self-diagnostic software. When a software or circuit problem is detected during operation, the **SERVICE** message is displayed on the monitor. For many problems, an error code is generated and displayed in the Info Menu.

To access the Info Menu, turn power off, then press **ON** while pressing and holding down **LEAD SELECT** and **HR ALARM** until the Test Menu is displayed. Press **▼ ECG SIZE** to scroll down to **INFO**, then press **HR ALARM** to display the Info Menu. The error code number is listed beside **FAULT STATUS**. Refer to Table 3-9 for the software or circuit associated with each error code.

To remove or "clear" an error code, press **HR ALARM** to scroll down to **RETAIN** (or **CLEAR**), then press **ECG SIZE ▲** to **CLEAR** the error. If more than one error code has been generated, the next error code will be displayed in sequence. After all error codes are cleared (and the **FAULT STATUS** displays **00**), press **LEAD SELECT** to exit the Info Menu and return to the Test Menu. Press **▼ ECG SIZE** to scroll down to **EXIT**, then press **HR ALARM** to resume normal operation.

After the error code is cleared, the **SERVICE** message is removed from the display. If, however, a software or circuit problem still exists or reoccurs, the **SERVICE** message is again displayed. Contact a Physio-Control representative for assistance.

**Table 3-9 Error Codes**

Error Code	Software or Circuit
1	Watchdog hardware (fast test)
2	Watchdog hardware (slow test)
3	Unknown transfer code
4	Unknown watchdog code
5	Recorder motor stalled/paper jam
6	Shock Advisory Adapter
7	System RAM test (U28)
8	System microprocessor RAM (U30)
9	System controller ROM (U27)
10	Critical ROM (U27)

**Table 3-9 Error Codes (cont.)**

<b>Error Code</b>	<b>Software or Circuit</b>
11	Display interface RAM (U13)
12	Display/recorder microprocessor RAM (U1)
13	Display interface ROM (U14)
14	D/A converter CRC
15	Transfer switching (Q4,CR4)
16	Transfer enable stuck on
17	Charge reference out of tolerance
18	Preamp baseline out of tolerance
19	Clock
20	+5V supply out of tolerance
21	+15V supply out of tolerance
22	Defib cal factors out of tolerance
23	A/D converter (U9) self-test
24	Recorder printhead resistance out of tolerance

## Introduction

This section provides the following information:

- Battery Maintenance
- General Maintenance
- Special Handling Procedures for Static Sensitive Devices
- Disassembly Procedures
- Inspection Techniques
- Tools and Materials for Cleaning and Repair
- Cleaning Procedures
- Printed Circuit Board Repair Precautions
- Preparation for Storage or Shipping.

## Battery Maintenance

The Battery Pack in the LIFEPAK 9 defibrillator/monitor provides short-term interim power while transporting patients or during other brief interruptions of ac power. The defibrillator/monitor automatically switches to battery power if the power cord is disconnected or the ac power source fails.

## Warning

**POSSIBLE DEFIBRILLATOR SHUTDOWN.** When operating on battery power, the large current draw required for defibrillator charging may cause the defibrillator to reach shutdown voltage levels with no low battery warning. If the defibrillator shuts down without warning, or if the **LOW BATTERY: CONNECT AC POWER** message appears on the monitor display, immediately connect the power cord to an ac power source.

## Recharging Batteries

The defibrillator/monitor continually charges the installed Battery Pack whenever the instrument is connected to an ac power source, even with the front panel power switched off (although the rear panel ac mains power switch must be on). The **BATT CHR** message appears on the lower left

corner of the monitor display during battery charging. A fully depleted Battery Pack is recharged to 90% capacity in three hours, and to full capacity in 24 hours. After full charging, the defibrillator/monitor continues to supply a trickle-charge which maintains the charge on the Battery Pack.

## Battery Maintenance Guidelines

The Battery Pack contains sealed lead-acid batteries which must be properly maintained to maximize battery life and performance. To properly maintain Battery Packs, follow these guidelines:

- Whenever ac power is available, keep the defibrillator/monitor connected to ac power (with the rear panel mains power switch on). This charges the Battery Pack as indicated by the **BATT CHRG** message on the monitor display.
- When the **LOW BATTERY: CONNECT AC POWER** message appears on the monitor display, immediately connect the ac power cord to an ac power source (with the rear panel mains power switch on) to continue operation and begin recharging the Battery Pack. Frequent use of the Battery Pack when it is at minimum reserve capacity will reduce battery life. If the low battery message occurs frequently, this may indicate that the Battery Pack needs to be replaced.
- Perform the Battery Capacity Check (p. 4-2) on the installed Battery Pack a minimum of every six months or whenever you suspect the Battery Pack may not be functioning properly.
- Replace the Battery Pack installed in the defibrillator/monitor a minimum of every two years.

## Guidelines for Replacement Batteries

End of battery life is inevitable. As batteries age, their charge capacities diminish. The Battery Pack installed in the defibrillator/monitor should be replaced a minimum of every two years as a preventive maintenance practice. To maximize the life and performance of replacement Battery Packs, follow these guidelines:

- Perform the Battery Capacity Check on any replacement Battery Pack at a minimum of every six months. (If it passes the Battery Capacity Check, be sure to recharge the Battery Pack for 24 hours before returning it to storage.)
- Recharge any new replacement Battery Pack as soon as you receive it before storing it or using it.
- Store replacement Battery Packs at 20° to 25°C (68° to 77°F).

## Battery Capacity Check

To check the capacity of a Battery Pack, perform the following steps (this procedure requires the use of a Defibrillator Energy Meter with a power range of 0-400J):

1. Install the Battery Pack in a LIFEPAK 9 defibrillator/monitor and charge the Battery Pack for at least 24 hours (if the Battery Pack is already fully charged, go on to the next step).

2. Disconnect the defibrillator/monitor from the ac power source.
3. Make sure the defibrillator/monitor power is on and it is operating from battery power (the **BATT CHRG** message is not displayed). Place the standard defibrillator paddles on the energy meter.

### Warning

**SHOCK HAZARD.** When charged and discharged as described in this procedure, the LIFEPAK 9 defibrillator/monitor discharges approximately 360J of electrical energy through the defibrillator paddles. Unless discharged safely as described in this procedure, this electrical energy may cause injury or death. Do not attempt to perform this procedure unless you are thoroughly familiar with the operation of the LIFEPAK 9 defibrillator/monitor.

4. Charge the defibrillator to 360J and discharge into the energy meter. Repeat this 4 more times for a total of five (5) 360J discharges within 2 minutes.
5. If the instrument shuts down due to power loss or if the **LOW BATTERY: CONNECT AC POWER** message appears, the Battery Pack has failed this procedure. Discard the Battery Pack and discontinue the procedure.

If the instrument continues to operate after step 4, leave the defibrillator/monitor operating on battery power for 45 minutes.

6. At the end of the 45 minutes, repeat step 4.

If the instrument shuts down due to power loss at any time, the Battery Pack has failed this procedure. Discard the Battery Pack.

If the instrument continues to operate on battery power after repeating step 4, the Battery Pack has passed the procedure and has useful life remaining. (It is acceptable for the **LOW BATTERY: CONNECT AC POWER** message to appear and remain on at this point.) **Recharge the Battery Pack for 24 hours before placing into service or storage.**

***Note:** Physio-Control Corporation recommends replacing the Battery Pack installed in the LIFEPAK 9 defibrillator/monitor after two years of service as a part of routine maintenance.*

## Recycling Batteries

In the United States, recycle Battery Packs locally according to national, state, and local regulations when Battery Packs are no longer useful. If local recycling is not possible, contact Physio-Control customer service specialists at 1-800-442-1142 for information on returning Battery Packs.

Outside the United States, recycle Battery Packs according to local regulations if possible. Otherwise, contact the local Physio-Control representative for information on returning Battery Packs.

---

## General Maintenance

The following paragraphs contain routine maintenance procedures that can be performed either by an experienced operator or a technician.

### Operation From AC or DC Power Source

To operate from ac power, plug the ac power cord of the instrument into a three-pin, grounded, ac power source. Do not use a free-ground adapter. The defibrillator/monitor operates on ac power whenever it is plugged in as described and the ON LED is on (the rear panel ac mains power switch must be on). Whenever ac power is connected, the Battery Pack is being recharged as indicated by the **BATT CHRG** message in the lower left corner of the monitor display.

To operate the instrument from the internal dc Battery Pack, disconnect the ac power cord from the ac power source and make sure the front panel power switch is pressed on.

### Strip Chart Recorder

Maintenance on the Strip Chart Recorder consists of loading paper and cleaning. Steps for these procedures follow, parenthetical numbers refer to parts shown in Figure 5-9, page 5-53.

The message **NO PAPER** will appear when the recorder paper runs out.

#### Caution

**Prevent Printhead Damage.** Use only Physio-Control recorder paper (PN804700) and do not operate the recorder without paper. Do not use waxed paper as this can damage the printhead.

### Loading Paper

1. Pull the latch (14) up and remove the empty paper spool.
2. Insert the new paper roll with the grid facing toward the front. Pull up a 2-inch length of paper.
3. Push the door (7) forward and the latch down until it latches.

## Cleaning

Clean the printhead and paper-out sensor periodically to remove paper dust and debris. At a minimum, clean after every 100 rolls of use. Perform these steps for cleaning:

1. Pull up the latch (14) and remove the paper roll.
2. Gently wipe the surface of the printhead and paper sensor with a cotton swab soaked in isopropyl alcohol. When cleaning the printhead, touch the printhead *only with the cotton swab*, not with your fingers.

## Protecting Printouts

Protect thermal paper printouts by following these guidelines:

- Do not apply tape or other adhesives over annotations or tracings on the front side of the paper. Apply adhesives only to the *back* of the paper.
- Store printouts only in *paper* folders. Do not store printouts in plastic folders.
- Avoid extended exposure to sunlight, temperatures above 27° C (81° F), or humidity above 70 percent.

## Fuse Replacement

The fuses are located in the rear panel of the instrument.

1. Place a thin, flat-blade screwdriver in the recessed area under the retaining tab of the fuseholder. Twist the screwdriver to release the retaining tab.
2. Pull the fuseholder out. Replace fuses with the same type, voltage rating, and current rating. Refer to the parts list (pg. 5-9).


---

## Special Handling Procedures For Static Sensitive Devices (SSDs)

Many electronic semiconductor devices such as MOS ICs, FETs, optical isolators, or film resistors can be damaged by the discharge of static electricity. It is very common for anyone to build up static charges, especially when wearing synthetic clothes, and to transfer this charge to any object touched. Such a discharge can damage or destroy Static Sensitive Devices (SSDs). In most cases, the discharge is not even perceptible to the person at fault.

In order to help prevent damage to SSDs due to static discharge, observe the following precautions when performing any open-case test, maintenance, or repair procedures:

## Look for SSD Symbol

Note that SSDs such as PCBs are indicated in this service manual with the following warning: 

**Use Static-Dissipative Mat**

Always perform repair or maintenance on a static-dissipative mat connected to earth ground.

**Wear Wrist Strap**

Always wear a conductive wrist strap connected to the mat and to ground except when working on energized equipment or when discharging high voltage circuits. The strap must be snug enough to make good contact against bare skin.

**Warning**

**SHOCK HAZARD.** Remove the wrist strap when working on energized equipment or when discharging high voltage circuits.

**Transport and Store PCBs Properly**

Transport and store PCBs in anti-static racks or inside conductive bags. Label the package containing the PCBs as static-sensitive.

**Keep Work Area Static-Free**

Keep static-generating products such as styrofoam cups or trays away from the work area. Connect all electrical equipment such as soldering irons and test equipment to ground through a three-prong plug.

**Test Work Area Routinely**

Test all the anti-static parts of the work area (mat, straps, cables) routinely. Keep a log of the test results.

---

**Disassembly Procedures**

The following procedures provide a logical sequence for disassembling the major components of LIFEPAK 9 defibrillator/monitor. Separate or disassemble only to the extent required. Parenthetical numbers refer to item numbers in the final assembly parts list (beginning on page 5-6) and Figure 5-1 (pg. 5-13). Reassembly procedures are the reverse unless otherwise noted.

**Warning**

**SHOCK HAZARD.** Disconnect the AC power cord and remove the battery pack before disassembly.

**Caution**

**Avoid Component Damage.** This instrument contains static sensitive devices (SSDs). Use the following special handling procedures for SSDs. SSDs are indicated in Section 5 with this symbol.





**Battery Pack Removal**

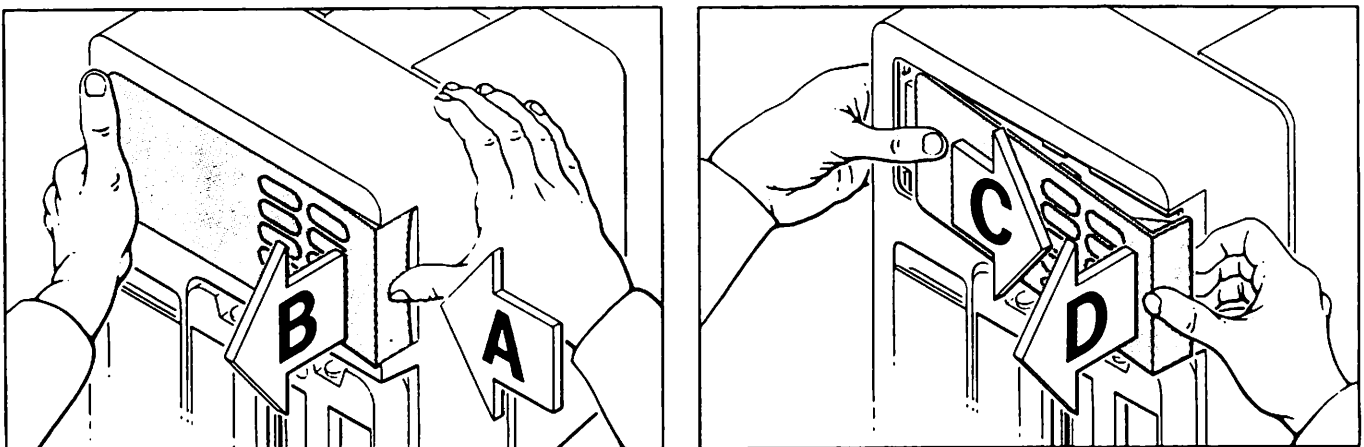
1. Open and remove the battery door (13) at the bottom of the instrument.

**Note:** When installing a replacement Battery Pack, be sure to charge the Battery Pack for 24 hours. Refer to Battery Maintenance on page 4-1.

2. Remove the Battery Pack (A13).
3. Free the Battery Pack by pressing the locking tab on the battery harness and separating the two connectors.

**Front Panel Bezel and Keypad Assembly Removal**

1. Press in on the right edge of the front panel bezel (2) as illustrated in Figure 4-1 (arrow A).
2. While pressing the edge, push out in the direction of arrow B until the right edge of the bezel releases.
3. Slide the bezel to the right slightly (arrow C) until the left tab clears the front case (5).
4. Place fingers under the released edge and pull the bezel away from the case (arrow D).
5. Press the quick-release levers and disconnect J20 from the Keypad Assembly (A6).
6. Remove the two screws (41) that hold the Keypad Assembly and CRT implosion shield (46) to the bezel. Slide out the shield and the Keypad Assembly.



**Figure 4-1 Front Panel Removal**

### **Strip Chart Recorder Removal**

1. Pull the upper edge of the top door to open the recorder (A8).
2. Remove the paper roll.
3. Push down the paper carrier and remove the two screws (41) at the rear of the paper housing.
4. Grasp the recorder at the bottom then pull down and away from the instrument.

### **Case Separation**

1. Remove the Battery Pack, front panel bezel, and strip chart recorder.
2. Turn the paddles connector counterclockwise, then pull to disconnect. Remove the paddles.
3. Remove three screws (41) from the bottom of the instrument, four screws (41) from the rear panel (31), and two screws (41) from the handle.
4. Pull the front case (5) forward and disconnect J36 (see Figure 4-2, page 4-9) located on the Interconnect PCB.
5. Pull the chassis (7) away from the rear case (6).

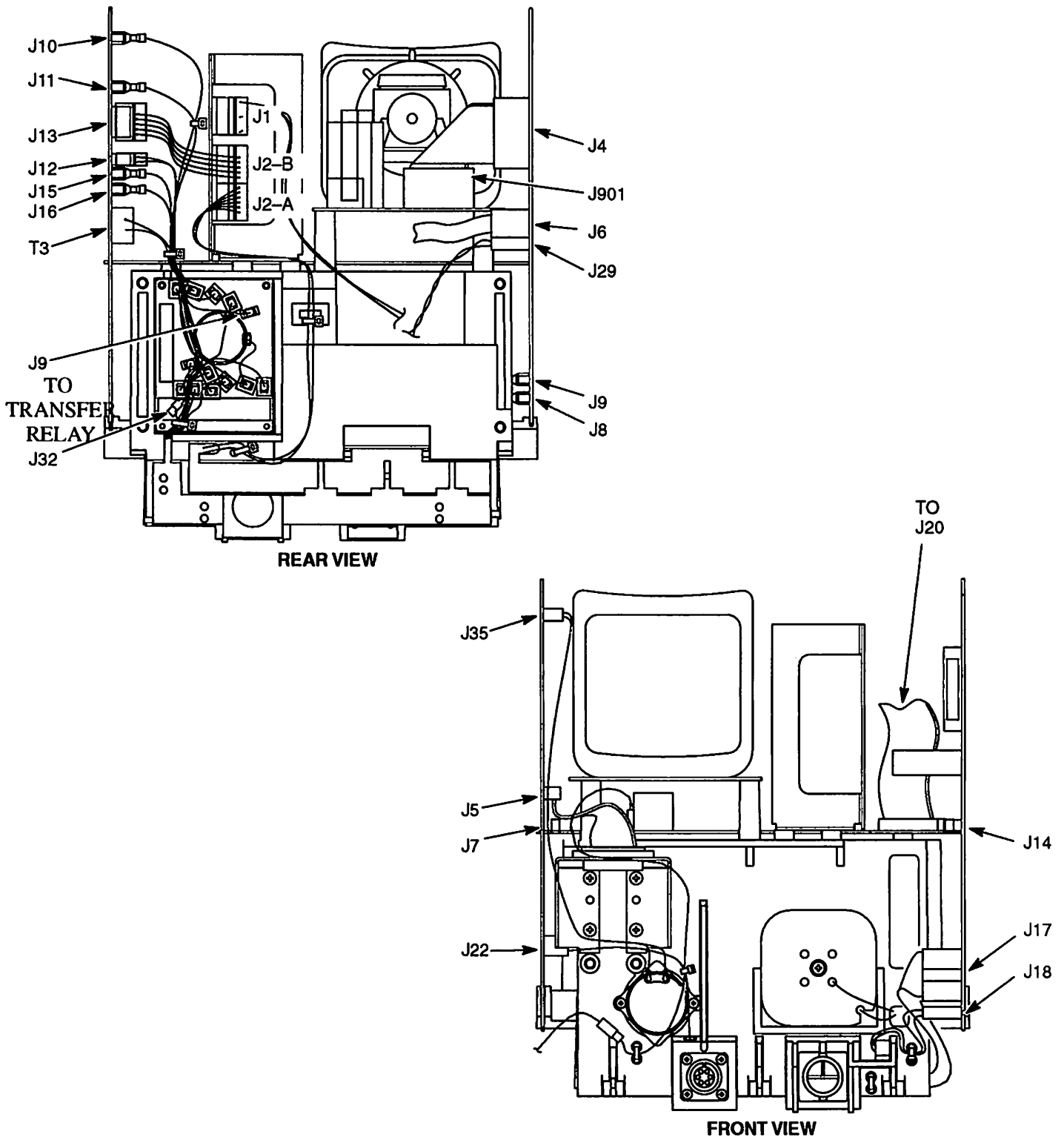


Figure 4-2 Connector Locations

## Power Conversion PCB Removal

Complete Case Separation. Refer to Figure 4-2, page 4-9:

1. Disconnect J17 and J18, located on the Power Conversion PCB (A3).
2. Push the Interconnect PCB (A5) locking tabs up to clear the notches in the Power Conversion PCB.
3. Pull the Power Conversion PCB away from the Interconnect PCB to disconnect J14 and lift the Power Conversion PCB out of the board guide.
4. Disconnect J10 through J13, then J15 and J16.
5. Temporarily place the Power Conversion PCB back into its original position. Remove the four screws (41) from the rear panel (31), disconnect J19, and free the rear panel from the chassis (7).
6. Disconnect J32 (wire labeled 2, goes to wave shaping inductor) and J9 (wire labeled 1 goes to Transfer Relay).

## Main PCB Removal

Complete Case Separation. Refer to Figure 4-2, page 4-9:

1. Press down the quick-release levers and disconnect J4 and J5.
2. Disconnect J22 on the Main PCB (A1).
3. Push the Interconnect PCB (A5) locking tabs up off of the notches in the Main PCB.
4. Pull the Main PCB away from the Interconnect PCB to disconnect P7 and lift the Main PCB out of the board guide.
5. Disconnect J8 and J9.

## Display PCB/CRT Assembly Removal

Complete Case Separation. Refer to Figure 4-2, page 4-9:

1. Press down the quick-release levers and disconnect J901 on the Display PCB/CRT Assembly (A11).
2. Remove four screws (41) to remove the Display PCB/CRT Assembly.

## Power Supply Removal

Complete Case Separation. Refer to Figure 4-2, page 4-9:

1. Disconnect J1 on the Power Supply PCB (A2).
2. Remove four screws (41) from the rear panel (31) and remove the rear panel.
3. Disconnect J2 on the Power Supply.
4. Remove four screws (41) from the Power Supply and detach from chassis (7).

## Interconnect PCB Removal

Complete Case Separation. Refer to Figure 4-2, page 4-9:

1. Remove the Power Conversion PCB, the Main PCB, the Display PCB/CRT Assembly, and the Power Supply PCB.
2. Disconnect J29.
3. Remove four screws (41) from the Interconnect PCB.

---

## Inspection Techniques

When servicing or repairing the instrument, routinely begin with a visual inspection of the hardware and components for signs of damage. Signs of damage require further inspection of the surrounding area for peripheral breakage or damage.

### Exterior Inspection

Visually inspect the entire instrument for wear, corrosion, deterioration, and damage resulting from extreme temperatures or dropping. Lift and hold the instrument upside down while listening for loose hardware.

### Interior Inspection

Table 4-1, Inspection Techniques, lists the major hardware components of the instrument, possible problems associated with each item, and recommended corrective actions.

**Table 4-1 Inspection Techniques**

<b>Hardware</b>	<b>Problem</b>	<b>Corrective Action</b>
Chassis, covers, and brackets	Warped, bent, damaged surfaces, or missing hardware	Replace
Components (mechanical and electrical)	Loose mountings	Repair
	broken or damaged leads	Replace
	Deterioration or leakage	Replace
Connector pins	Slightly bent	Straighten
	Badly bent, loose or corroded	Replace
Nameplate, labels, and decals	Not legible	Replace
PCB surfaces	Charred, cracked, or brittle	Replace PCB
	<i>Note: Some discoloration of the PCB surface can be expected due to the high operating temperatures of some components.</i>	
Screws and nuts	Loose or cross-threaded	Tighten or replace
Terminals and connections	Installed incorrectly	Install correctly
	Missing or worn	Replace
	Failed solder connections	Resolder (if not damaged) or replace
Wire insulation and tubing	Deteriorated, worn, pinched, or damaged	Replace

## Tools and Materials for Cleaning and Repair

Table 4-2 lists recommended tools, materials, and chemicals required for cleaning and repair activities. Although specific items are recommended, tools and materials with specifications equivalent to those listed may be used.

**Table 4-2 Tools and Materials for Cleaning and Repair**

Product	Description
Static-protected work area Electronic Supply Dealers	Grounded conductive surface and wrist strap
X-32B and Xersin <sup>®</sup> solder Multicore Westbury, NY 11590	Low flux, no cleaning necessary
5-Minute <sup>®</sup> Epoxy Devcon Danvers, MA 01923	Adhesive
Tak Pak <sup>®</sup> Loctite Newington, CT 06111	Adhesive and 710 accelerator
Crocus cloth	
Isopropyl alcohol	
Acid brush	
Cotton swabs	
Vacuum cleaner	
Soft-bristle brush	Nonmetallic
Cloth	Clean and lint-free
Compressed air	Clean and dry (60psi, max.)

## Cleaning Procedures

Clean the instrument after maintenance, disassembly, or any repair procedure.

### External Cleaning

Clean the instrument case, cables, and screen with mild soap and water. Use only a damp sponge or towel to clean.

### Warning

**SHOCK OR FIRE HAZARD.** Do not immerse any portion of the instrument in water. Fluid spills and splashes may damage the instrument's electrical components.

### Caution

**Possible Instrument Damage.** Do not autoclave the instrument.

## Interior Cleaning

Follow disassembly procedures (beginning on page 4-6) to access the interior.

### Warning

**PERSONAL SAFETY HAZARD.** Ventilate work area when using solvents. Observe manufacturer warnings regarding personnel safety and emergency first aid. Keep first aid equipment available when using chemicals.

### Warning

**CHEMICAL FIRE HAZARD.** Observe shop safety and fire precautions. Store solvents and solvent-soaked rags in approved containers. Refer to manufacturers instructions on containers for recommended firefighting procedures. Keep firefighting equipment available.

### Caution

**Possible Component Damage.** This instrument contains static sensitive devices (SSDs). Use special handling procedures on page 4-5.

### Caution

**Possible Component Damage.** Do not use solvents to clean transformers or inductors.

1. Brush surfaces and parts with a nonmetallic soft-bristle brush. Remove loosened dirt and dust using dry low pressure compressed air (60psi) or a vacuum cleaner.
2. Wipe metal surfaces with a soft, nonabrasive cloth dampened with isopropyl alcohol.

### Caution

**Prevent Nameplate Damage.** Do not use abrasive cleaners or solvents to wipe nameplates and labels—the nameplate information may disappear.

3. Wipe surfaces of nameplates and labels with a clean, dry cloth.

### Caution

**Possible Component Damage.** Do not use solvents to clean plastic parts.



4. Clean surfaces of plastic parts with a mild soap and water solution. Dry with a clean cloth.
5. Clean soldering surfaces with a nonmetallic, soft-bristle brush dipped in isopropyl alcohol then wipe with absorbent cloth. Air dry 10 minutes or use low pressure compressed air (60psi) before soldering.

---

## PCB Repair Precautions

The LIFEPAK 9 defibrillator/monitor uses multilayer PCBs which are not easily repaired. They consist of alternate layers of conductive patterns and insulating material bonded together and interconnected with plated-through holes. The internal layers and connection points are quickly damaged by too much heat, rendering the entire PCB useless. Therefore, it is recommended that all multilayer PCBs be returned to Physio-Control for repair or replacement.

### Caution

**Possible PCB damage.** Improper handling can easily damage the PCBs beyond repair. Plated-through holes connecting the circuitry on two sides of the PCB can be damaged by too much heat.

*Note: Before attempting any PCB repair, contact Physio-Control. Customer PCB repair may endanger any applicable PCB exchange agreement or other warranty.*

## Preparation for Storage or Shipping

Save the original shipping box and packing for the LIFEPAK 9 defibrillator/monitor. If the instrument must be shipped to the service center or factory, the special packaging is required to prevent shipping damage. Refer to Figure 4-3 when repacking.

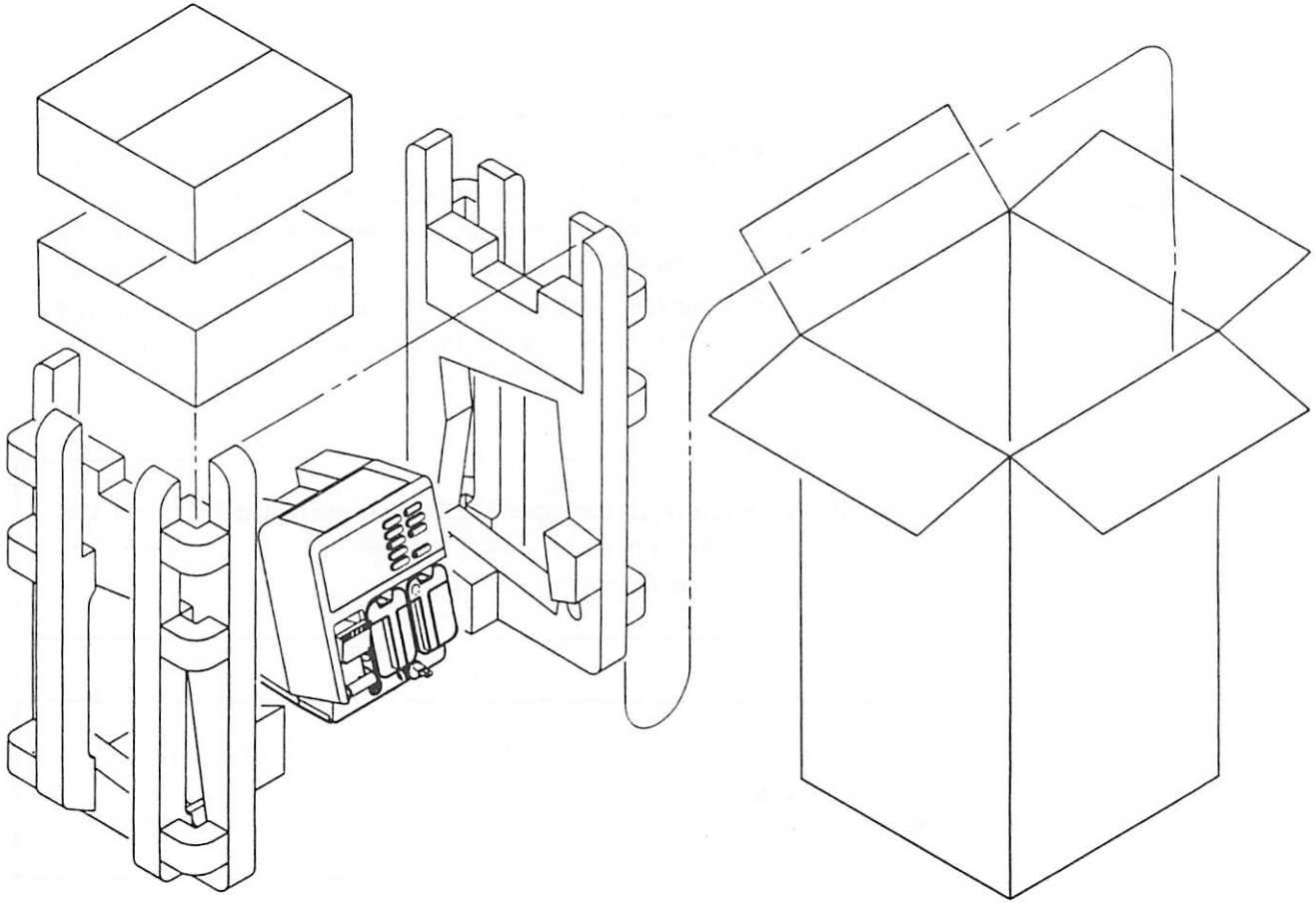


Figure 4-3 LIFEPAK 9 defibrillator/monitor Shipping Assembly

## Introduction

This section includes lists of replaceable parts, component layouts or exploded views, and schematic diagrams for each major assembly of the LIFEPAK 9 defibrillator/monitor and the optional Defibrillation Adapter. This information is provided to assist in troubleshooting and repair. Table 5-1 lists the figure and page number of the major assemblies for the defibrillator/monitor. Table 5-2 lists the figure and page number of the major assemblies for the defibrillator/monitor. Table 5-3 lists standard reference designators for components. Supplies and accessories are listed in Table 5-4.

## Parts List

Use parts lists to identify *replaceable* parts. The format for each list is the same:

**Ref:** This column contains the reference designators or the assigned item numbers of replaceable parts. Reference designators are abbreviated (see Table 5-3) and are listed alphanumerically by this abbreviation. Assigned item numbers are listed numerically, starting with 2. The number in the heading of this column indicates the figure to which the parts list corresponds.

**Part Number:** Physio-Control Corporation part number is listed in this column. Part ordering information is provided on page 5-2.

**Description:** Descriptive information for a part that is used more than once refers to the initial listing with a "Same as \_\_\_" citation. This citation may also list a component value when necessary. Static Sensitive Devices (SSDs) are identified in this column by this symbol:



For information about proper handling of SSDs during repair or replacement, refer to page 4-5.

**Use Code:** Different hardware configurations and their corresponding letter codes are listed at the beginning of each parts list. Subsequent use of any letter code indicates which part is used in a particular configuration. A blank in this column indicates that the part is used in all configurations.

**Qty:** The quantity column specifies the *total* quantity used for each part number listed. The abbreviation REF indicates a major assembly or subassembly.

### Component Layouts or Exploded Views

Use component layouts or exploded views to locate parts. The reference designator or assigned item number on the drawing corresponds to the REF column entry on the parts list.

### Schematic Diagrams

Schematic diagrams depict circuit function and signal flow. Signal names, pin numbers, and polarities are labeled on the schematics as well as reference designators and values from the parts list.

- In general, signal flow is from left to right
- Circuit names on schematics correspond to descriptions in Section 1
- ICs marked with a ✱ are detailed in Section 6
- To/From labels correspond to connections shown on the interconnect diagram.

This manual documents the revision levels of the assemblies which were in production at the time of publication. Since the time of publication, it is possible that modifications to the assemblies have occurred which are not documented in this manual. For assistance in obtaining updated information in the US, call PARTSLINE at 1-800-442-1142. Outside the US, contact your local Physio-Control representative.

---

### How to Order Parts

When ordering from Physio-Control Corporation in the US, call the toll free PARTSLINE number (1-800-442-1142). Give the instrument part number and serial number located on the bottom panel of your instrument. Then specify all assembly numbers, part numbers, reference designations, and descriptions. Different parts may be substituted by Physio-Control to reflect modifications and improvements of instrument circuitry. To order parts outside the US, contact your local Physio-Control representative.

**Table 5-1 LIFEPAK 9 defibrillator/monitor Major Assemblies**

Ref	Part Number	Nomenclature	Fig. No.	Page No.
REF	803800	LIFEPAK 9 defibrillator/monitor Final Assembly	5-1	5-13
		Interconnect Diagram	5-2	5-14
A1	803715	Main PCB Assembly ▲	5-3	5-24
A2	803726	Power Supply PCB Assembly	5-4	5-32
A3	803724	Power Conversion PCB Assembly ▲	5-5	5-41
A4	----	Not used		
A5	803761	Interconnect PCB Assembly ▲	5-6	5-47
A6	803771	Keypad Assembly	5-7	5-50
A7	803741	Rear Panel Membrane Switch	5-8	5-51
A8	804189	Strip Chart Recorder Assembly ▲	5-9	5-53
A9	800240	Transfer Relay Assembly	5-10	5-55
A10	802901	Paddle Assembly	5-11	5-56
A11	803706	Display PCB/CRT Assembly	5-12	5-59
A12	----	Chassis/Harness Assembly	N/A	N/A
A13	803704	Battery Pack (shown on Final Assembly)	N/A	N/A
W1	803783-30	Power Supply PCB/AC Receptacle/Ground Wire Harness	5-13	5-68
W2	803783-23	Power Conversion PCB/Power Supply PCB/Battery Wire Harness	5-14	5-69
W3	803783-24	Battery Sensor/Power Supply PCB Wire Harness	5-15	5-70
W4	803756-13	High Voltage Connector Cable Assembly	5-16	5-71
W5	803733-00	Main PCB/Display Cable Assembly	5-17	5-72
W6	803773-00	Main PCB/Recorder Cable Assembly	5-18	5-73
W7	803772-00	Interconnect PCB/Keypad Cable Assembly	5-19	5-74
W8	803783-00	Main PCB/Patient Connector Wire Harness	5-20	5-75
W9	803783-04	AC Receptacle/Ground Wire Harness	5-21	5-76
W10	803783-05	AC Receptacle Wire Harness	5-22	5-76
W11	803783-06	Test Load Contact/Resistor Wire Harness	5-23	5-77
W12	803783-07	Power Conversion PCB/Reed Assembly Wire Harness	5-24	5-77
W13	803783-08	Power Conversion PCB/Dump Relay Wire Harness	5-25	5-78
W14	803783-09	Power Conversion PCB/Charge Relay Negative Wire Harness	5-26	5-79
W15	803783-10	Power Conversion PCB/Charge Relay Positive Wire Harness	5-27	5-79
W16	803783-11	Main PCB/Sternum Relay Wire Harness	5-28	5-80
W17	803783-12	Main PCB/Apex Relay Wire Harness	5-29	5-80
W18	803783-13	Storage Capacitor Positive/Relay Wire Harness	5-30	5-81
W19	803783-14	Storage Capacitor Negative/Relay Wire Harness	5-31	5-81
W20	803783-15	ECG Out Wire Harness	5-32	5-82
W21	803783-19	Recorder/Bracket Ground Wire Harness	5-33	5-83
W22	803783-29	Power Supply Bracket/Ground Wire Harness	5-34	5-84

**Table 5-2 Defibrillation Adapter Assemblies**

<b>Ref</b>	<b>Part Number</b>	<b>Nomenclature</b>	<b>Fig. No.</b>	<b>Page No.</b>
<b>REF</b>	803747	Defibrillation Adapter	5-35	5-86
<b>W1</b>	803774-03	Test Load High Voltage Wire Harness	5-36	5-88
<b>W2</b>	803774-04	Test Load High Voltage Wire Harness	5-37	5-88
<b>W3</b>	803774-05	Pushbutton Switch Wire Harness	5-38	5-89
<b>W4</b>	803756-09	High Voltage Connector Cable Assembly	5-39	5-90

**Table 5-3 Reference Designator Key**

<b>Designator</b>	<b>Description</b>
A	Main Assemblies
C	Capacitor
CR or D	Diode
F	Fuse
H	Heat Sink
J	Jack Connector
JP	Jumper Wire
K	Relay
L	Inductor
P	Plug Connector
Q	Transistors
R	Resistor
RN	Resistor Network
RV	Varistor
RT	Thermistor
S	Switch
T	Transformer
TP	Test Point
U	IC (Integrated Circuit)
VSP	Voltage Surge Protector
W	Wire Harness
Y	Crystal
XU	IC Socket

## Supplies and Accessories

Supplies and accessories for the LIFEPAK 9 defibrillator/monitor are listed in Table 5-4 with the Physio-Control part number. To order an item in the U.S., call the Physio-Control PARTSLINE at 1-800-442-1142. Outside the U.S., contact your local Physio-Control representative.

Use of non-Physio-Control defibrillation electrodes, batteries, accessories, or adapter devices may void Safety Agency Certifications and warranty.

**Table 5-4 Supplies and Accessories**

Description	Quantity	Part Number
<b>Adapter, Defibrillation</b>		803747
<b>Adapter, Shock Advisory</b>		803732
<b>Cable, Defibrillation</b> (for use with FAST-PATCH disposable defibrillation/ECG electrodes)		804089
<b>Cable, Patient</b>	3-lead, AHA	9-10418
	3-lead, IEC	800947
<b>Cord, Power</b>		803619
<b>DERMA JEL Electrode Jelly</b>	4-ounce tube	9-10236-00
	Case (12 tubes)	9-10236-012
<b>Electrode, FAST-PATCH disposable defibrillation</b> (use with Defibrillation Adapter for LIFEPAK 9 defibrillator/monitor, P/N 803747)	1 set (2 electrodes)	804545-001
	10 sets (20 electrodes)	804545-010
	50 sets (100 electrodes)	804545-050
<b>Electrode, LIFE•PATCH, pre-gelled (disposable)</b>	Box of 30 (10 pkgs/box)	800139-030
	Case of 300 (10 boxes/case)	800139-300
<b>Operating Instructions</b>		804882
<b>Paper, Recorder, 50 mm x 30m (100ft)</b>	Box of 3 rolls	804700-003
	Case (150 rolls)	804700-150
<b>Paddle, Pediatric, external, 2 required</b>		800418
<b>Paddle, Posterior, external, adult</b>		802461
<b>Service Manual</b>		803763
<b>Shipping Container for Battery Recycling</b>		805984

5-1 Ref	Part Number	Description	Use Code	Qty
		<b>LIFEPAK 9 Final Assembly:</b>		
	803800-01	French, 220V	A	REF
	803800-02	German, 220V	B	REF
	803800-03	Spanish, 220V	C	REF
	803800-04	Spanish, 110V	D	REF
	803800-05	French, 120V	E	REF
	803800-06	French, CSA, 120V	F	REF
	803800-07	English, CSA, 120V	G	REF
	803800-08	English, UK, 220V	H	REF
	803800-09	English, 120V	I	REF
	803800-10	French, 220V	J	REF
	803800-11	German, 220V	K	REF
	803800-12	Spanish, 220V	L	REF
	803800-13	Spanish, 110V	M	REF
	803800-14	French, 120V	N	REF
	803800-15	French, CSA, 120V	O	REF
	803800-16	English, CSA, 120V	P	REF
	803800-17	English, UK, 220V	Q	REF
	803800-18	English, 120V	R	REF
	803800-19	French, 220V	S	REF
	803800-20	German, 220V	T	REF
	803800-21	Spanish, 220V	U	REF
	803800-22	Spanish, 110V	V	REF
	803800-23	French, 120V	W	REF
	803800-24	French, CSA, 120V	X	REF
	803800-25	English, CSA, 120V	Y	REF
	803800-26	English, UK, 220V	Z	REF
	803800-28	English, 120V	AA	REF
	803800-29	French, 120V	AB	REF
	803800-30	German, 220V	AC	REF
	803800-31	Spanish, 220V	AD	REF
	803800-32	Spanish, 110V	AE	REF
	803800-33	French, 120V	AF	REF
	803800-34	French, CSA, 120V	AG	REF
	803800-35	English, CSA, 120V	AH	REF



5-1 Ref	Part Number	Description	Use Code	Qty
	803800-36	English, UK, 220V	AI	REF
	803800-300	English, 120V, ECG OUT	AJ	REF
	803800-301	French, 220V	AK	REF
	803800-303	Spanish, 220V	AL	REF
	803800-304	Spanish, 110V	AM	REF
	803800-305	French, 120V	AN	REF
	803800-306	French, CSA, 120V	AO	REF
	803800-307	English, CSA, 120V	AP	REF
	803800-308	English, UK, 220V	AQ	REF
	803800-309	Portuguese, 110V	AR	REF
	803800-310	Portuguese, 220V	AS	REF
	803800-311	Italian, 220V	AT	REF
	803800-312	Swedish, 220V	AU	REF
	803800-313	German, 220V	AV	REF
	803800-314	English (Japan), 120V, ECG OUT	AW	REF
	803800-315	English, CSA, 120V, ECG OUT	AX	REF
	803800-316	English, Intl., CSA, 120V, ECG OUT	AY	REF
A1	803715-11	Main PCB Assembly ▲ <i>Note: If ordering a Main PCB Assembly, order U14 and U27 separately. Refer to Main PCB Assembly parts list.</i>		1
A2	803726-01	Power Supply PCB Assembly		1
A3	803724-03	Power Conversion PCB Assembly ▲		1
A5	803761-02	Interconnect PCB Assembly ▲		1
A6	803771-16	Keypad Assembly, English	I,G,H,P-R,Y,Z,AA,AH,AI,AJ,AP,AQ,AW-AY	1
	803771-17	Keypad Assembly, French	A,E,F,J,N,O,S,W,X,AB,AF,AG,AK,AN,AO	1
	803771-18	Keypad Assembly, German	B,K,T,AC,AV	1
	803771-19	Keypad Assembly, Spanish	C,D,L,M,U,V,AD,AE,AL,AM	1
	803771-20	Keypad Assembly, Portuguese	AR,AS	1
	803771-21	Keypad Assembly, Italian	AT	1
	803771-22	Keypad Assembly, Swedish	AU	1
A7	803741-01	Rear Panel Switch Membrane		1
A8	804189-00	Strip Chart Recorder Assembly ▲		1
A9	800240-14	Transfer Relay Assembly		1

5-1 Ref	Part Number	Description	Use Code	Qty
A10	802901-06	Paddle Assembly		1
A11	803706-00	Display PCB/CRT Assembly	AJ-AO,AQ-AT,AW-AY	1
	803706-01	Display PCB/CRT Assembly	AU,AV	1
A13	803704-02	Battery Pack		1
W1	803783-30	Power Supply/AC Receptacle/Ground Wire Harness		1
W2	803783-23	Power Conversion PCB/Power Supply/Battery Wire Harness		1
W3	803783-24	Battery Sensor/Power Supply PCB Wire Harness		1
W4	803756-13	High Voltage Connector Cable Assembly		1
W5	803733-00	Main PCB/Display PCB Cable Assembly		1
W6	803773-00	Main PCB/Strip Chart Recorder Cable Assembly		1
W7	803772-00	Interconnect PCB/Keypad Cable Assembly		1
W8	803783-00	Main PCB/Patient Connector Wire Harness		1
W9	803783-04	AC Receptacle/Ground Wire Harness		1
W10	803783-05	AC Receptacle/Ground Wire Harness		1
W11	803783-06	Test Load Contact/Resistor Wire Harness		2
W12	803783-07	Power Conversion PCB/Reed Assembly Wire Harness		1
W13	803783-08	Power Conversion PCB/Dump Relay Wire Harness		1
W14	803783-09	Power Conversion PCB/Charge Relay Negative Wire Harness		1
W15	803783-10	Power Conversion PCB/Charge Relay Positive Wire Harness		1
W16	803783-11	Main PCB/Sternum Relay Wire Harness		1
W17	803783-12	Main PCB/Apex Relay Wire Harness		1
W18	803783-13	Storage Capacitor Positive/Relay Wire Harness		1
W19	803783-14	Storage Capacitor Negative/Relay Wire Harness		1
W20	803783-15	ECG Out Wire Harness	AJ-AY	1
W21	803783-19	Recorder/Bracket Ground Wire Harness		1
W22	803783-29	Power Supply Bracket/Ground Wire Harness		1
2	803744-02	Bezel, front control panel		1
3	803729-02	Bracket, Strip Chart Recorder		1
4	803705-00	Capacitor, storage		1
5	803749-07	Case, front, with inserts		1
6	803740-01	Case, rear, ECG Out		1

5-1 Ref	Part Number	Description	Use Code	Qty
7	803722-06	Chassis		1
8	803737-00	Clip, mounting, test-load resistor		2
9	803718-00	Clip, power entry module	I,R,AA,AJ,AR-AU,AW-AY	1
10	201393-011	Connector, plug, equipotential		1
11	202110-000	Connector, receptacle, quick-connect, 6A/250V		1
12	803736-00	Contact, test load		2
13	803711-01	Door, battery		1
14	200363-025	Fastener, plastic rivet, 0.125 D		1
15	802885-00	Foot, mounting		4
16	200256-151	Fuse, slow blow, 4A/250V	D-G,I-Z,AA,AE-AH,AJ,AM-AP,AW-AY	2
	200619-018	Fuse, slow blow, 2A/250V	A-C,H,AB-AD,AI,AK,AL,AQ,AS-AV	2
17	201605-011	Grommet, continuous, serrated (not shown)		1
18	802793-05	Inductor, waveshaping		1
19	805531-00	Label, blank		1
20	803743-21	Label, front panel, French	A,E,F,J,N,O,S,W,X,AB,AF,AG,AK,AN,AO	1
	803743-22	Label, front panel, German	B,K,T,AC,AV	1
	803743-23	Label, front panel, Spanish	C,D,L,M,U,V,AD,AE,AL,AM	1
	803743-24	Label, front panel, English	I,G,H,P-R,Y,Z,AA,AH,AI,AJ,AP,AQ,AW-AY	1
	803743-25	Label, front panel, Portuguese	AR,AS	1
	803743-26	Label, front panel, Italian	AT	1
	803743-27	Label, front panel, Swedish	AU	1
21	803742-00	Label, instruction, English	AQ,AW,AY	1
	803742-01	Label, instruction, French	A,E,J,N,S,W,AB,AF,AK,AN	1
	803742-02	Label, instruction, German	B,K,T,AC,AV	1
	803742-03	Label, instruction, Spanish	C,D,L,M,U,V,AD,AE,AL,AM	1
	803742-04	Label, instruction, French	I,F,O,R,X,AG,AO	1
	803742-05	Label, instruction, English, CSA	G,H,P,Q,R,Y,Z,AA,AH,AI,AJ,AP,AX	1
	803742-06	Label, instruction, Portuguese	AR,AS	1
	803742-07	Label, instruction, Italian	AT	1
	803742-08	Label, instruction, Swedish	AU	1
22	802940-03	Label, paddle, APEX	A,I,R,AA	1
	802940-08	Label, paddle, APEX, domestic	AJ,AW,AY	1
	802940-11	Label, paddle, APEX, international	J-Q,AB-AI,AK-AV,AX	1

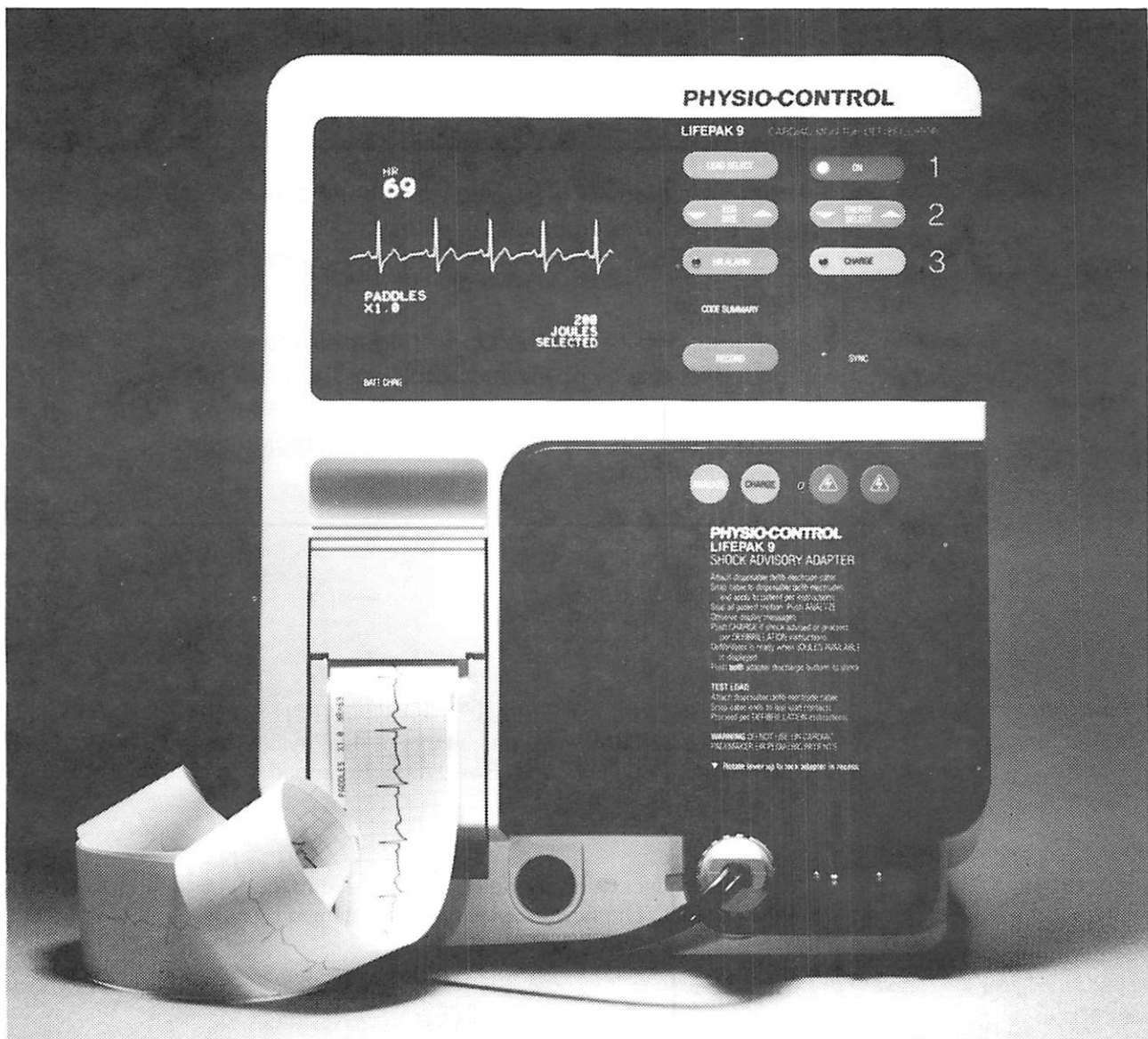
5-1 Ref	Part Number	Description	Use Code	Qty
23	802940-07	Label, paddle, STERNUM, domestic (not shown, used on A10)	A,B,E-H,I,J,K,S,TN-R,W-Z,AA,AJ,AW,AY	1
	802940-09	Label, paddle, STERNUM, Spanish (not shown, used on A10)	C,D,L,M,U,V,AD,AE,AL,AR,AS	1
	802940-10	Label, paddle, STERNUM, international (not shown, used on A10)	J,K,N,O,P,Q,T,W-Z,AB,AC,AF-AI,AK,AN-AQ,AT-AV,AX	1
24	803739-03	Label, rear panel, French	A,E,I,N,S,W,AB,AF	1
	803739-04	Label, rear panel, German	B,K,T,AC	1
	803739-05	Label, rear panel, Spanish	C,D,L,M,U,V,AD,AE	1
	803739-06	Label, rear panel, English, UK	H,Q,Z,AI	1
	803739-07	Label, rear panel, French, CSA, 120V	F,O,X,AG	1
	803739-08	Label, rear panel, English	I,G,P,Y,AA,AH	1
	803739-10	Label, rear panel, English, CSA, ECG Out	AJ,AP,AW-AY	1
	803739-11	Label, rear panel, French, 110V/220V, ECG Out	AK,AN	1
	803739-12	Label, rear panel, German	AV	1
	803739-13	Label, rear panel, Spanish, 110V/220V, ECG Out	AL,AM	1
	803739-14	Label, rear panel, UK, 220V, ECG Out	AQ	1
	803739-15	Label, rear panel, French, CSA, 110V, ECG Out	AO	1
	803739-22	Label, rear panel, Portuguese	AR,AS	1
	803739-17	Label, rear panel, Italian	AT	1
	803739-18	Label, rear panel, Swedish	AU	1
25	803727-07	Label, serial number, French, International	A	1
	803727-08	Label, serial number, German, International	B	1
	803727-09	Label, serial number, Spanish, International	C	1
	803727-10	Label, serial number, Spanish, Domestic	D	1
	803727-11	Label, serial number, French, Domestic	E	1
	803727-12	Label, serial number, French, CSA	F	1
	803727-13	Label, serial number, English, CSA	G	1
	803727-14	Label, serial number, English, UK	H	1
	803727-15	Label, serial number, English, Domestic	I	1
	803727-16	Label, serial number, French, International	J	1
	803727-17	Label, serial number, German, International	K	1
	803727-18	Label, serial number, Spanish, International	L	1
	803727-19	Label, serial number, Spanish, Domestic	M	1
	803727-20	Label, serial number, French, Domestic	N	1
	803727-21	Label, serial number, French, CSA	O	1

5-1 Ref	Part Number	Description	Use Code	Qty
	803727-22	Label, serial number, English, CSA	P	1
	803727-23	Label, serial number, English, UK	Q	1
	803727-24	Label, serial number, English, Domestic	R	1
	803727-25	Label, serial number, French, International	S	1
	803727-26	Label, serial number, German, International	T	1
	803727-27	Label, serial number, Spanish, International	U	1
	803727-28	Label, serial number, Spanish, Domestic	V	1
	803727-29	Label, serial number, French, Domestic	W	1
	803727-30	Label, serial number, French, CSA	X	1
	803727-31	Label, serial number, English, CSA	Y	1
	803727-32	Label, serial number, English, UK	Z	1
	803727-34	Label, serial number, English, Domestic	AA,AJ,AW	1
	803727-35	Label, serial number, French, International	AB,AK	1
	803727-36	Label, serial number, German, International	AC,AV	1
	803727-37	Label, serial number, Spanish, International	AD,AL	1
	803727-38	Label, serial number, Spanish, Domestic	AE,AM	1
	803727-39	Label, serial number, French, Domestic	AF,AN	1
	803727-40	Label, serial number, French, CSA	AG,AO	1
	803727-41	Label, serial number, English, CSA	AH,AP,AX	1
	803727-42	Label, serial number, English, UK	AI,AQ	1
	803727-44	Label, serial number, Portuguese	AR	1
	803727-46	Label, serial number, Italian	AT	1
	803727-48	Label, serial number, Swedish	AU	1
	803727-72	Label, serial number, Portuguese, 220V	AS	1
	803727-98	Label, serial number, English, Domestic	AY	1
26	805377-06	Label, reference, Japanese (not shown, next to serial number label)	AW	1
27	801517-04	Label, UL (not shown, next to serial number label)	AJ,AX	1
28	803456-15	Label, specification, battery (not shown, next to battery pack)		1
29	800943-09	Label, high voltage symbol, International (not shown, used on A11 and A9)		4
30	201508-002	Nut, kep, locking, #6-32		6
31	803713-03	Panel, rear, ECG Out	AJ-AW	1
32	802935-05	Pushbutton, paddle, charge, domestic	A,E-H,I,J,N-Q,R,S,AA,AB, AF-AI,AJ,AK,AN-AQ,AW-AY	1
	802935-06	Pushbutton, paddle, charge, German	B,K,T,AC,AV	1

5-1 Ref	Part Number	Description	Use Code	Qty
	802935-07	Pushbutton, paddle, charge, Spanish	C,D,L,M,U,V,AD,AE,AL,AM,AR,AS	1
	802935-18	Pushbutton, paddle, charge, Italian	AT	1
	802935-19	Pushbutton, paddle, charge, Swedish	AU	1
33	802935-08	Pushbutton, paddle, discharge, domestic	D,E-G,I,N-P,R,W-Y,AA,AE-AH,AJ,AM-AP,AR,AW-AY	2
	802935-09	Pushbutton, paddle, discharge, International	A-C,H,J-L,S-U,Q,Z,AB-AD,AI,AK,AL,AQ,AS-AV	2
34	800516-02	Resistor, defibrillator (not shown, behind inductor)		1
35	802608-00	Resistor, 50Ω, 50W, 5%		1
36	200536-001	Retainer, cable tie, nylon, 0.10 W x 4 L (not shown)		15
37	200536-011	Retainer, cable tie, nylon, 0.35 W x 20.9 L		2
38	200530-002	Retainer Clamp, cable, D-type, plastic		1
39	200040-019	Retaining Ring, steel, 1.127 OD		1
40	201874-270	Screw, pan head, #4-40 x 0.312 L		12
41	201874-277	Screw, pan head, #8-32 x 0.375 L	A-Z,AB-AI,AK-AQ,AV	36
	201874-277	Screw, pan head, #8-32 x 0.375 L	AA,AJ,AR-AU,AW-AY	37
42	201874-287	Screw, pan head, #8-32 x 0.500 L		4
43	201874-276	Screw, pan head, #6-32 x 0.375 L		2
44	803768-00	Shield, recorder bracket		1
45	803759-00	Shield, high voltage, Power Conversion PCB		1
46	803770-02	Shield, implosion, CRT		1
47	803717-01	Shield, preamp, circuit-side		1
48	803716-01	Shield, preamp, component-side		1
49	202250-003	Sleeve, ferrite snap (not shown, near connector receptacle on rear panel)	AU,AV	3
50	803730-00	Spacer, battery pack (not shown, under battery door)		1
51	201625-171	Spring, compression, 0.300 OD, 0.562 L		2
52	803735-01	Spring, paddle retention		2
53	200192-294	Standoff, hex, 0.312 W x 1.875 L		2
54	201501-012	Tape, adhesive foam, 0.125 T x 1 W (not shown, under W12)		A/R
55	200283-005	Tubing, heat shrink, red, 0.250 ID (not shown, used on connector receptacle)		A/R
56	200804-018	Washer, flat, 0.375 OD, 0.152 ID, 0.045 T		2
57	200804-101	Washer, flat, #8		8

# Shock Advisory Adapter

for use with the LIFEPAK® 9 family of defibrillator/monitors



## Service Manual

Manual No. 805345-01

November 1994

**Corporate Headquarters:**

**Physio-Control**

11811 Willows Road Northeast

Post Office Box 97006

Redmond, WA 98073-9706 USA

Telephone: 206/867-4000

Toll Free: 800/426-8047 or 800/442-1142

Fax: 206/867-4161

**Part No.** \_\_\_\_\_

**Serial No.** \_\_\_\_\_

**About This Manual:** This Service Manual is intended for use by technical service personnel. It describes how to maintain, test, troubleshoot, and repair the Shock Advisory Adapter.

A separate publication, the **Operating Instructions**, is intended for use by physicians, clinicians, and emergency care personnel. It provides step-by-step instructions for all operating features of the Shock Advisory Adapter as well as operator-level testing and maintenance.

**Trademarks**

PHYSIO-CONTROL®, LIFEPAK®, FAST-PATCH®, and SAS (SHOCK ADVISORY SYSTEM)™ are trademarks of the Physio-Control Corporation, 11811 Willows Road N.E., PO Box 97006, Redmond, WA 98073-9706.

**Warranty**

Refer to the product warranty statement included in the accessory kit shipped with the product. Duplicate copies may be obtained by contacting your local Physio-Control sales or service office.

**Defibrillator Tracking**

US only, including US government-owned units:  
Under the Safe Medical Devices Act of 1990, defibrillator manufacturers and distributors are required to track the location of defibrillators. If your defibrillator has been sold, donated, lost, stolen, exported, or destroyed, or if it was not obtained directly from Physio-Control, please notify Physio-Control at 800-442-1142, extension 4530.



# Table of Contents

---

## Safety Information

Introduction .....	viii
Terms .....	viii
Warnings .....	ix
Symbols .....	xi

---

## General Information

Service Information .....	xii
Effective Publication Dates .....	viii
Configuration Information .....	xiv
Content Overview .....	xv

---

## Description 1

Introduction .....	1-1
Physical Description .....	1-1
Functional Description .....	1-4
Theory of Operation .....	1-6
SAS Adapter PCB Assembly (803779) .....	1-6
Power Supply .....	1-6
Preamp .....	1-6

Microcontroller Core . . . . . 1-8  
Instrument Interface . . . . . 1-9  
Microcontroller Inhibit . . . . . 1-10

---

**Operation 2**

Introduction . . . . . 2-1  
Controls and Indicators . . . . . 2-1

---

**Testing 3**

Introduction . . . . . 3-1  
Performance Inspection Procedure (PIP) . . . . . 3-1  
PIP-Scope and Applicability . . . . . 3-1  
PIP-Definitions . . . . . 3-1  
PIP-Requirements . . . . . 3-1  
    PIP-Required Equipment . . . . . 3-1  
    PIP-Test Equipment Verification . . . . . 3-2  
    PIP-Workstation . . . . . 3-2  
    PIP-Personnel . . . . . 3-2  
PIP-Physical Inspection . . . . . 3-3  
PIP-Analyze . . . . . 3-3  
PIP-VF Detection and Shock . . . . . 3-3  
PIP-Leads Off . . . . . 3-3  
PIP-Motion Detection . . . . . 3-4  
PIP-Test Load . . . . . 3-4  
PIP-Leakage Current . . . . . 3-5  
PIP Checklist . . . . . 3-7  
Functional Test and Calibration Procedures . . . . . 3-9  
Servicing Guidelines . . . . . 3-9  
TCP-Scope and Applicability . . . . . 3-9  
TCP-Definitions . . . . . 3-9  
TCP-Requirements . . . . . 3-9  
    TCP-Equipment Requirements . . . . . 3-9  
TCP-Setup . . . . . 3-10  
TCP-Power Supply and Oscillator Checks . . . . . 3-10  
Preamp Gain . . . . . 3-11

---

**Service and  
Maintenance**      **4**

**Introduction** ..... 4-1

**Special Handling Procedures For Static Sensitive  
Devices (SSDs)** ..... 4-1

Use Static-Dissipative Mat ..... 4-1

Wear Wrist Strap ..... 4-1

Transport and Store PCBs Properly ..... 4-2

Keep Work Area Static-Free ..... 4-2

Test Work Area  
Routinely ..... 4-2

**Disassembly Procedures** ..... 4-2

Case Separation ..... 4-2

SAS Adapter PCB Removal ..... 4-2

**PCB Repair Precautions** ..... 4-2

**Inspection Techniques** ..... 4-3

Exterior Inspection ..... 4-3

Interior Inspection ..... 4-3

**Tools and Materials for Cleaning and Repair** ..... 4-3

**Cleaning Procedures** ..... 4-4

Exterior Cleaning ..... 4-4

Interior Cleaning ..... 4-5

**Shipping Assembly** ..... 4-7

---

**Parts Lists/  
Schematics**      **5**

**Introduction** ..... 5-1

Parts List ..... 5-1

Component Layouts or Exploded Views ..... 5-2

Schematic Diagrams ..... 5-2

**How to Order Parts** ..... 5-2

**Supplies and Accessories** ..... 5-5

---

**Component  
Reference**      **6**

**Introduction** ..... 6-1

**Component Reference Diagrams** ..... 6-3

**List of Figures**

<b>Description</b>	<b>1</b>	Figure 1-1	LIFEPAK 9 Shock Advisory Adapter Location ..	1-2
		Figure 1-2	LIFEPAK 9 defibrillator/monitor with Shock Advisory Adapter .....	1-3
		Figure 1-3	LIFEPAK 9 Shock Advisory Adapter Functional Block Diagram .....	1-5
<b>Operation</b>	<b>2</b>	Figure 2-1	Front Panel Controls and Indicators .....	2-2
<b>Testing</b>	<b>3</b>	Figure 3-1	Display Flow Diagram .....	3-8
		Figure 3-2	Test Signal Setup .....	3-11
<b>Service and Maintenance Parts Lists/Schematics</b>	<b>4</b>	Figure 4-1	LIFEPAK 9 shock advisory adapter Shipping Assembly .....	4-7
			<b>5</b>	Figure 5-1
		Figure 5-2	Interconnect Diagram .....	5-8
		Figure 5-3	SAS Adapter PCB Assembly .....	5-13
		Figure 5-4	Pushbutton Switch Wire Harness .....	5-17
		Figure 5-5	Test Load Switch/PCB Wire Harness .....	5-18
		Figure 5-6	Test Load High Voltage Wire Harness .....	5-18
		Figure 5-7	Test Load High Voltage Wire Harness .....	5-19
	Figure 5-8	High Voltage Connector Cable Assembly .....	5-20	
<b>Component Reference Diagrams</b>	<b>6</b>	Figure 6-1	EPROM .....	6-2
		Figure 6-2	Latch .....	6-2
		Figure 6-3	Microcontroller .....	6-3
		Figure 6-4	Pulse-Width Modulator .....	6-4
		Figure 6-5	RAM .....	6-5

---

## List of Tables

<b>Description</b>	<b>1</b>	Table 1-1	General Specifications . . . . .	1-3
<b>Operation</b>	<b>2</b>	Table 2-1	Controls and Indicators . . . . .	2-3
<b>Testing</b>	<b>3</b>	Table 3-1 Table 3-2 Table 3-3	PIP Test Equipment . . . . . Test and Calibration Test Equipment . . . . . Power Supply and Oscillator Checks . . . . .	3-2 3-8 3-8
<b>Service and Maintenance</b>	<b>4</b>	Table 4-1 Table 4-2	Inspection Techniques . . . . . Tools and Materials for Cleaning and Repair . . . . .	4-3 4-4
<b>Parts Lists/ Schematics</b>	<b>5</b>	Table 5-1 Table 5-2 Table 5-3	Major Assemblies . . . . . Reference Designator Key . . . . . Accessories and Supplies . . . . .	5-3 5-3 5-3
<b>Component Reference</b>	<b>6</b>	Table 6-1	Component Reference Diagrams . . . . .	6-1

# Safety Information

---

## Introduction

This safety information includes terms and symbols used in this manual or on the equipment to alert both operating and service personnel of recommended precautions in care, use and handling of this specialized medical equipment.

Refer to NFPA 99-1990, **Health Care Facilities**, and NFPA 70-1990, **National Electrical Code** for specific guidelines on the standards and practices for health-care instruments and environments.

---

## Terms

Certain terms are used in this manual, or on the equipment. Familiarize yourself with their definitions and significance.

**Danger:** Immediate hazards which **will** result in serious personal injury or death.

**Warning:** Hazards or unsafe practices which **could** result in serious personal injury or death.

**Caution:** Hazards or unsafe practices which **could** result in minor personal injury or product damage.

**Note:** Points of particular interest for more efficient or convenient instrument operation. Additional information or explanation concerning the subject under discussion.

## General Warnings and Cautions

Following are descriptions of general hazards and unsafe practices that could result in death, severe injury or product damage. Specific warnings and cautions not appearing in this section are found throughout the manual.

### ⚠ WARNINGS

**Possible fire or explosion.** Do not operate this product in the presence of flammable gases or anesthetics. Explosion or fire can result. Refer to safety documents NFPA 99-1990, **Use of Inhalation Anesthetics (Flammable and Nonflammable)**, and NFPA 70-1987, **National Electrical Code (Health Care Facilities section)**, before operating this product in the proximity of flammable gases or anesthetics.

**Shock or fire hazard.** Do not immerse any portion of this device in water or other fluids. Avoid spilling any fluids on device or accessories.

**Shock hazard.** When charged and discharged, the LIFEPAK 9 defibrillator/monitor, with the shock advisory adapter installed, discharges up to 360J of electrical energy. Unless discharged properly as described in this manual, this electrical energy may cause personal injury or death. Do not attempt to discharge the defibrillator unless you are thoroughly familiar with the operation of the LIFEPAK 9 defibrillator/monitor and the shock advisory adapter.

**Possible improper device performance.** Use only Physio-Control ECG and defibrillation cables, disposable defibrillation electrodes, ECG electrodes, and batteries mentioned in this manual. Substitution of non-Physio-Control cables, electrodes, or batteries may cause the device to perform improperly.

**Possible electrical interference with ECG monitoring.** Equipment which emits certain radio frequency signals can cause electrical interference and distort the displayed or recorded ECG signal, thereby preventing accurate rhythm analysis. To minimize radio interference, move or reposition radio away from defibrillator.

**Patient hazard.** Do not mount instrument directly above patient. Place the instrument in a location where it cannot harm the patient should it fall from its shelf or other mount.

**⚠ WARNING**

**Shock or fire hazard.** Equipment or accessories improperly interconnected to each other can be a source of ignition or have a shock potential. Make sure that all equipment is interconnected safely in accordance with NFPA (National Fire Protection Association) 70-1990, *National Electric Code*.

**Note.** Within certain governmental jurisdictions, all interconnected accessory equipment must be labeled by an approved testing laboratory. It is important that you verify and observe the required applications in your location. Check leakage current and grounding requirements after interconnecting this instrument with accessory equipment.

**CAUTIONS**

**Possible instrument damage.** Sterilization environments can cause severe damage to the instrument and accessories. Do not autoclave or gas sterilize accessories unless manufacturer instructions clearly approve it.

**Possible instrument damage.** Broken or frayed wires, or loose snap fittings may cause interference or loss of signal. Pay particular attention to the point at which the wires enter the terminals. Repeated flexing at these points eventually causes the wire strands to break. Perform frequent electrical and visual inspections on cables and wires.



## Symbols

Any or all of the following symbols may appear in this manual or on the equipment:



Static Sensitive Device (SSD)



Additional information in Section 6, Component References



**DANGER** — high voltage present



**ATTENTION** — refer to manual for more information



Protective ground (earth) terminal



Equipotentiality connector



Off (Power: disconnection from the mains)



On (Power: connection to the AC mains)

# General Information

---

## **Service Information**

Before attempting to clean or repair any assembly in this instrument, the technician should be familiar with the information provided in Section 4, **Service and Maintenance**.

A qualified technician should check a product that has been dropped, damaged, or severely abused to verify the instrument is operating within performance standards as listed in Section 3, **Performance Inspection Procedure (PIP)**, and that the leakage current values are acceptable.

If calibration or more extensive testing is required, a qualified technician can perform the **Test and Calibration Procedure (TCP)**, also in Section 3. Component replacement and internal adjustments must be performed only by personnel qualified by appropriate training and experience.

The use of defibrillation electrodes and adapter devices from sources other than Physio-Control is not recommended. Physio-Control has no information regarding performance of electrodes and adapter devices from other sources. If instrument failure is attributed to electrodes or adapters not manufactured by Physio-Control, the warranty may be voided.

Component replacement and internal adjustments must be made by service personnel qualified by appropriate training and experience.

If assistance in servicing the instrument is needed in the USA, contact Physio-Control at 1-800-442-1142. Outside the USA, contact your local Physio-Control service or sales representative.

---

**Effective  
Publication Dates**

The effective publication date for each page of this manual is listed below.

<b>Title</b>	<b>Page</b>	<b>Date</b>
Trademark and Warranty	ii	Nov 1994
Table of Contents	iii thru v	Nov 1994
Safety Information	viii thru xi	Nov 1994
General Information	xii thru xviii	Nov 1994
<b>1</b> Description	1-1 thru 1-10	Nov 1994
<b>2</b> Operation	2-1 thru 2-3	Nov 1994
<b>3</b> Testing	3-1 thru 3-10	Nov 1994
<b>4</b> Service and Maintenance	4-1 thru 4-7	Nov 1994
<b>5</b> Part Lists/Schematics	5-1 thru 5-20	Nov 1994
<b>6</b> Component Reference	6-1 thru 6-5	Nov 1994

---

**Configuration  
Information**

This manual is current with the listed revision level of the following part numbers. The assemblies appear in the same order as in Table 5-1.

---

<b>Assembly Name</b>	<b>Part Number</b>	<b>Rev</b>
Shock Advisory Adapter	803732	A8
SAS Adapter PCB Assembly	803779-05,-06	C4
Wiring Harnesses	803774-01 thru -04	A4
High Voltage Connector Cable Assembly	803756-10	A7

---

---

## **Content Overview**

This manual contains the following information:

### **Section 1**

**Description:** This section details how the instrument works. Input signals, power supplies, PCB functions, and instrument outputs are described. Each PCB circuit description is accompanied by a block diagram to illustrate the major circuits. Circuit names in these block diagrams also appear in the appropriate schematics in Section 5.

### **Section 2**

**Operation:** This section familiarizes the user with basic equipment function. It identifies Controls, Indicators, and Connectors, and screen menu options. This section is not intended to instruct the operator in the clinical use of the instrument; such detailed instructions are provided in the separate *Operating Instructions* manual.

### **Section 3**

**Testing/Troubleshooting:** This section contains the Performance Inspection Procedure (PIP)—sequential steps to follow when performing an operational closed-case check of the equipment. A PIP checklist is provided which can be duplicated and used during testing. The Test and Calibration Procedure (TCP) in this section describes calibration and more extensive instrument testing.

### **Section 4**

**Service and Maintenance:** This section provides Disassembly/Assembly Procedures for removing all major subassemblies. The procedures are referenced to numbered parts in the Final Assembly drawing in Section 5. This section includes instructions for inspecting, cleaning, maintaining, and repairing the instrument.

### **Section 5**

**Parts Lists/Schematics:** This section contains a list of Supplies and Accessories, Illustrated Parts Lists, PCB Component Layouts, and Schematic Diagrams for all repairable assemblies.

### **Section 6**

**Component Reference Diagrams:** An aid to troubleshooting, this section consists of Component Reference Diagrams for selected Integrated Circuits (ICs). The ICs in Section 6 are identified in the schematics in Section 5 with a large asterisk \*.

---

## **Introduction**

This section describes the features, specifications, and circuitry for the accessory LIFEPAK 9 shock advisory adapter. This section is divided into three parts:

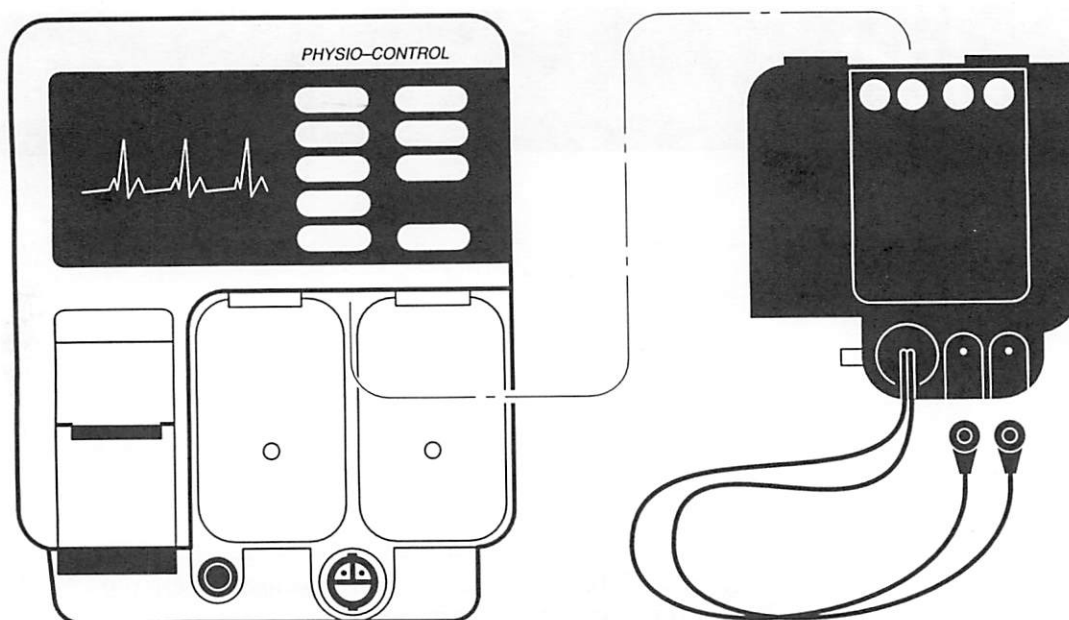
- Physical Description describes general features and lists specifications
- Functional Description briefly describes the function of the major assemblies
- Theory of Operation provides circuit descriptions to the major component level.

---

## **Physical Description**

The LIFEPAK 9 functions as an automatic advisory defibrillator when the adapter is used. The adapter fits into the paddle wells on the front on the LIFEPAK 9 defibrillator/monitor when the standards paddles are removed (see Figure 1-1). The adapter can be used with any of the LIFEPAK 9 family of defibrillator/monitor/pacemakers. These are:

- LIFEPAK 9 defibrillator/monitor
- LIFEPAK 9A defibrillator/monitor
- LIFEPAK 9B defibrillator/monitor
- LIFEPAK 9P defibrillator/monitor/pacemaker

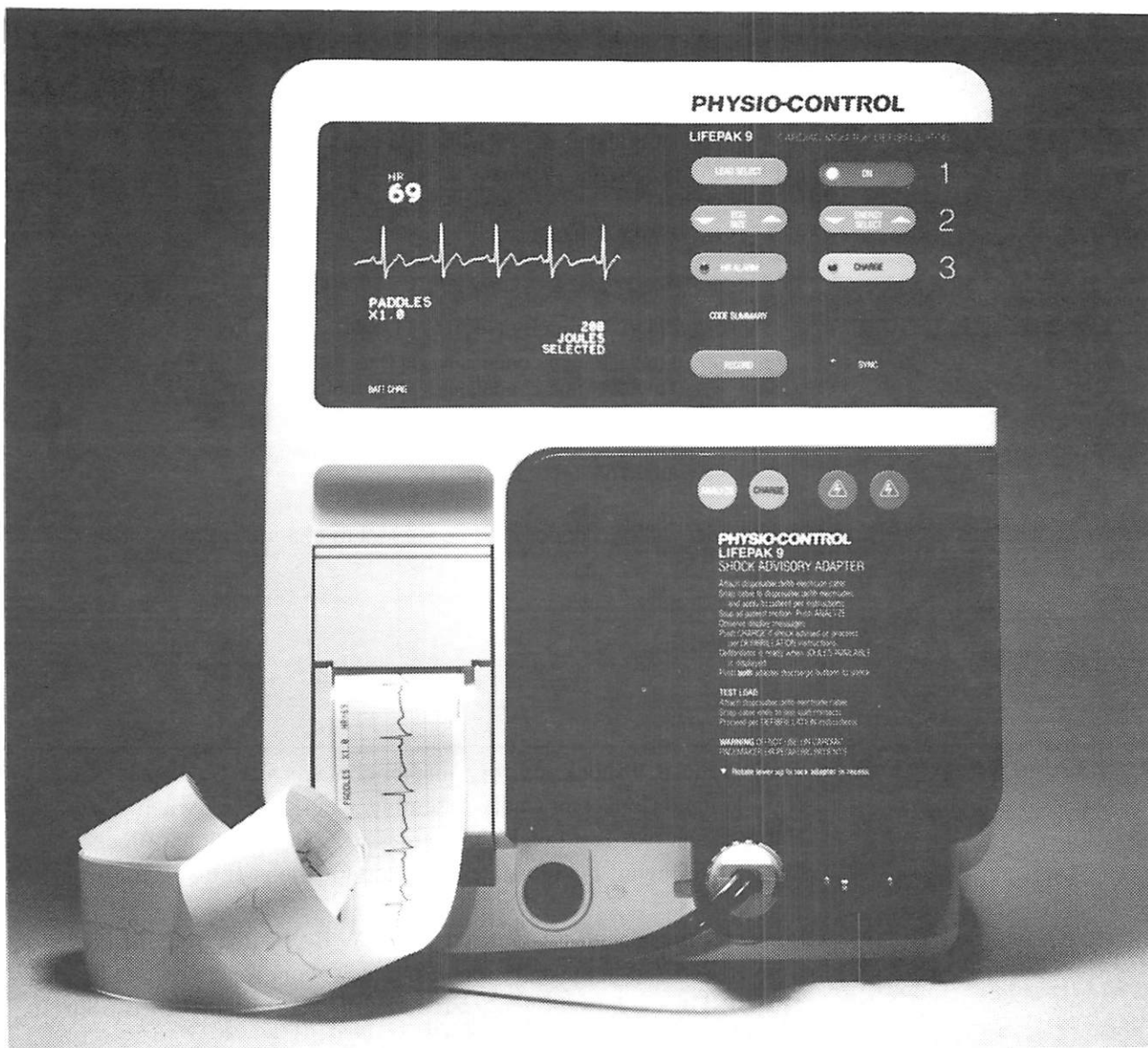


**Figure 1-1 LIFEPAK 9 shock advisory adapter Location**

The LIFEPAK 9 shock advisory adapter (see Figure 1-2) analyzes patient ECG through FAST-PATCH disposable defibrillation electrodes. The adapter then determines if defibrillation is necessary and displays the appropriate message on the lower left corner of the monitor screen.

The defibrillator/monitor CODE SUMMARY function records patient information when the adapter completes ECG analysis. At power-on, the adapter runs a self-test. The message SERVICE ADAPTER displays on the lower left corner of the monitor screen if the self-test fails. The instrument will not function until the self-test succeeds.

Defibrillation charge function can be tested using the adapter in the same way as in the defibrillator/monitor. The disposable defibrillation electrodes connect to snap fittings in the adapter. The snap fittings connect to a test load in the LIFEPAK 9 defibrillator/monitor for charge energy dump. A test load switch next to the left test load connector contact closes when the disposable defibrillation electrodes connect. This signals the defibrillator that an energy discharge is impending, allowing the instrument to capture the current data.



**Figure 1-2 LIFEPAK 9 defibrillator/monitor with shock advisory adapter**



**Table 1-1 General Specifications**

Characteristic	*Quantity or Specifications
General	
OUTPUT ENERGY (DELIVERED)	200 to 360J automatic mode, 1 to 360J manual mode (from defibrillator, $\pm 10\%$ with 50 $\Omega$ load)
SIZE	18.8cm H x 19.2cm W x 5.6cm D (7.4in H x 7.55in W x 2.2in D)
WEIGHT	0.86kg (1.9lbs)
Environmental	
ATMOSPHERIC PRESSURE	797 to 500mm Hg (-570 to 11,000ft).
RELATIVE HUMIDITY	0 to 95% (non-condensing) at 0 to 34°C (32 to 94°F). 0 to 80% (non-condensing) at 35 to 45°C (95 to 113°F).
TEMPERATURE RANGE	
Operating	0 to 45°C (32 to 113°F)
Storage	-30 to 65°C (-22 to 149°F)

\*All specifications at 20°C unless otherwise stated. Specifications subject to change without notice.

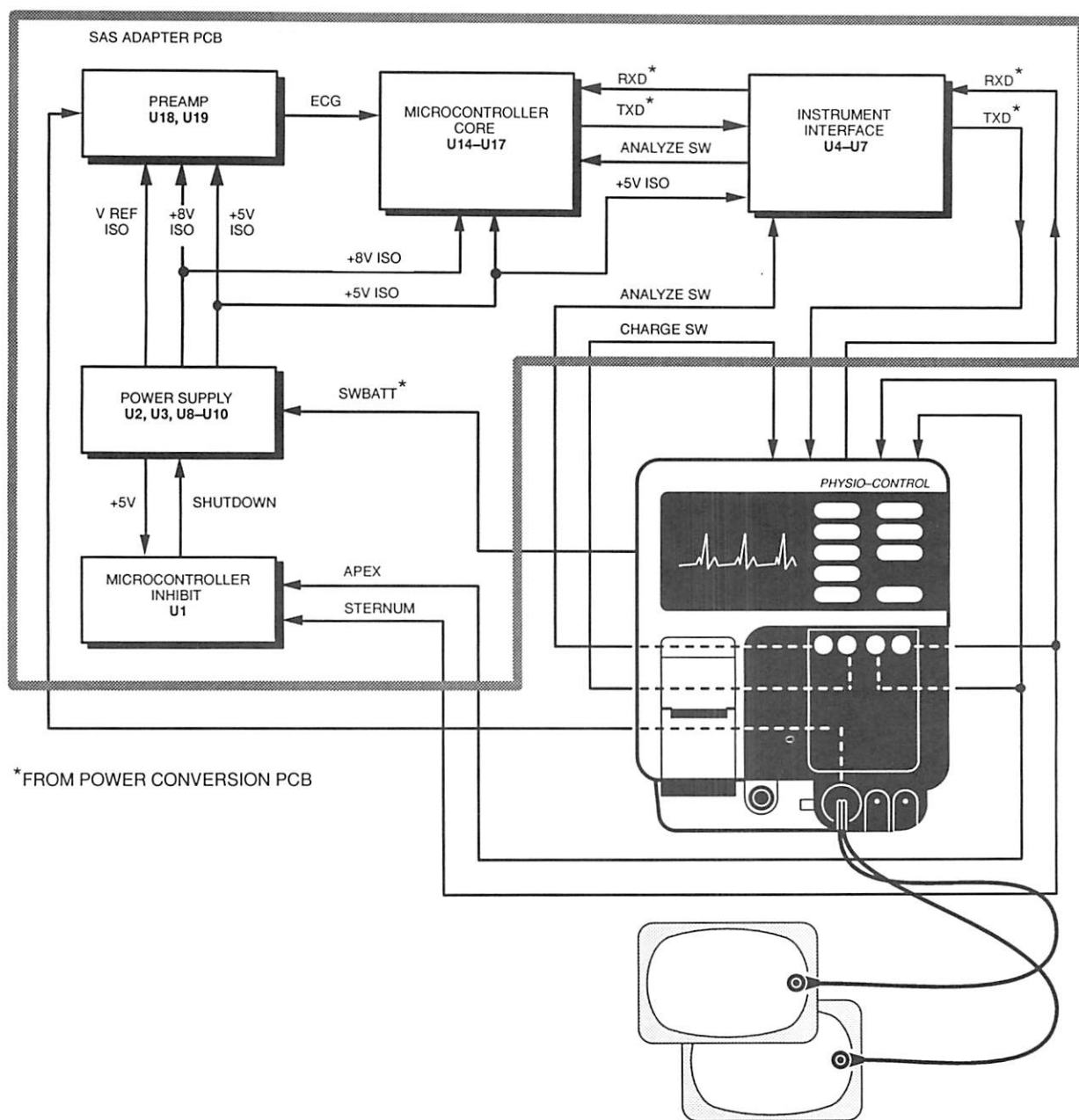
### Functional Description

The LIFEPAK 9 shock advisory adapter contains a SAS Adapter PCB, a High Voltage Connector Cable Assembly, a Pushbutton Switch Wire Harness, and two Test Load Wire harnesses. The Functional Block Diagram in Figure 1-3 illustrates the main functions of the instrument.

Power for the adapter is supplied by the SW BATT line from the Power Conversion PCB in the defibrillator/monitor. Four separate voltages are generated by the Power Supply circuit on the SAS Adapter PCB from SW BATT.

During ECG analysis, the FAST-PATCH disposable defibrillation electrodes capture incoming patient ECG. The Preamp circuit conditions the ECG signal for sampling by the microcontroller in the Microcontroller Core circuit. Pressing ANALYZE on the front panel stores sampled data into this circuit, otherwise data is not saved. The Microcontroller Inhibit circuit shuts down the Power Supply circuit to protect the microcontroller from transient voltages.

Commands from the adapter front panel are isolated by the Instrument Interface circuit. Serial communication between the microcontroller and the Power Conversion PCB in the defibrillator/monitor is also isolated by the Instrument Interface circuit.



**Figure 1-3 LIFEPAK 9 Shock advisory adapter Functional Block Diagram**

---

## Theory of Operation

The following paragraphs describe the SAS Adapter PCB. Schematic diagrams of these electrical circuits in Section 5 should be referred to while reading. Section 6 contains additional information about selected ICs (indicated by a \* on the schematic) to aid in circuit analysis and troubleshooting.

### SAS Adapter PCB Assembly (803779)

The SAS Adapter PCB contains all of the electrical components. The five primary circuits are:

- Power Supply
- Preamp
- Microcontroller Core
- Instrument Interface
- Microcontroller Inhibit.

#### Power Supply

The Power Supply circuit provides isolated and nonisolated power for all circuits on the SAS Adapter PCB. Pulse-width modulator U2 drives the isolated supplies; transformer T1 provides patient isolation.

Pulse-width modulator U2 alternately turns on transistors Q3 and Q4 from outputs QA and QB. The outputs of both transistors are isolated across T1 (slightly stepped down) and rectified by CR6 and CR7, providing isolated voltage for the regulators and opto-isolators.

Regulator U8 reduces the isolated voltage to +8V for the preamp operating voltage. General +5V VREF power throughout the SAS Adapter PCB is regulated by U9. Regulator U10 reduces the isolated voltage for all digital microcircuits. Operating voltages for the nonisolated components are provided by regulator U3.

#### Preamp

The Preamp circuit amplifies the ECG signal and determines the patient impedance before the microcontroller analyzes the ECG.

Microcontroller U17 automatically stops analyzing the incoming ECG signal whenever predetermined patient impedance levels are exceeded. This could be due to uneven paddle contact with the patient or excessive motion. Both Preamp circuit functions are performed mainly by custom hybrids U19 and U18. Hybrid U18 amplifies the ECG signal; identical hybrid U19 determines patient impedance.

Input protection for the custom hybrids is essential, since they are connected directly to the paddles. Positive and negative transients are shunted to ground by CR2 through CR5. Resistor R31 limits the current to both hybrids. Additional input protection for U19 is provided by VSP2, C27, and R22.

Impedance is determined by sending a drive signal to the patient and measuring the signal drop across the patient. U19 produces this signal as a 14kHz sinewave at the ZDRV output (pin 4). The drive signal returns to U19 at the ZIN input (pin 7). A synchronous demodulator within U19 detects the returning drive signal. An internal comparator uses this signal to detect a loose lead condition. If a lead becomes disconnected, the voltage on one input of the comparator exceeds the threshold set at U19 pin 21, driving the output at pin 22 low. This low output activates the microcontroller high speed input (HSI.3).

The same U19 demodulator output is also directed to an internal amplifier similar to U18 (see the following paragraph) between pins 8 and 9. Hard-wired control signals G1 through G3 fix the gain at 2V/mV. The microcontroller then evaluates the impedance signal output at pin 15 for excessive motion.

Hybrid U18 amplifies the ECG signal in two stages: first with a fixed gain setting, then with a variable gain setting. During the first stage, gain is fixed as  $120 \pm 18\%$  with a 1mV input signal. U18 also contains a 60Hz notch filter and a low pass filter for the ECG signal input. capacitor C23 and U19 output-coupling capacitor C19 form a discrete 2–22Hz bandpass filter.

During the second stage, the microcontroller varies the ECG gain to meet input requirements of its internal A/D converter (pin 5). The microcontroller selects the second-stage gain by supplying a three-bit code to the G1 through G3 inputs of hybrid U18. The four selectable gain factors listed below are referenced to a 1mV ECG input.

Gain Factor	Inputs		
	G1	G2	G3
0.5V/mV	High	High	High
1V/mV	Low	High	High
2V/mV	Low	Low	High
4V/mV	Low	Low	Low

Op amps U20A and U20B buffer the output signals at pin 15 of both hybrids. Buffering is necessary to match the high impedance outputs of the hybrids to the low impedance inputs of the microcontroller A/D converters. This compensates for any signal attenuation that may occur when the hybrid output signals are transmitted to the microcontroller.

Hybrids U19 and U18 require a stable voltage reference (VREF) for precise measurement of patient signals. The +8VA line provides this reference signal at pin 18 of both hybrids. Resistors R33 and R34 divide the +8VA line to approximately +4V; C26 filters VREF at power-on.

## Microcontroller Core

The Microcontroller Core circuit analyzes patient information from the Preamp. The microcontroller is a 16-bit microprocessor with an internal analog-to-digital (A/D) converter required for ECG signal analysis. Microcontroller U17 is the main component and supporting components are the following: EPROM U14, RAM U15, latch U16, clock U13, and NAND gate U12.

Clock oscillator U13 generates the microcontroller operating 10MHz clock pulse. NAND gate U12B and U12C buffer the output of U13 to the microcontroller.

A reset circuit on the +5V ISO supply protects the microcontroller from power-up transients and defibrillation pulses. The reset circuit generates an active-low reset signal at the output of inverter U11A. When +5V ISO power is removed, both inputs of NAND gate U12A switch low, producing a logic high on the output. U11A inverts the signal to reset the microprocessor.

The reset pulse is active for a period between 5ms and 50ms each time the +5V ISO supply is turned on. An RC network consisting of R27 and C13 at U12A pin 2 delay the +5V ISO supply, giving the microcontroller sufficient off-time to protect itself.

U17 Microcontroller protection during defibrillation starts when the Microcontroller Inhibit circuit shuts down the Power Supply circuit and holds U17 in reset. With the Power Supply disabled, the negative voltage at the gate of Q8 decays to zero volts through R35 and C34. Capacitor C13, normally charged, must be discharged to hold the microcontroller in reset. When the voltage at the gate of Q8 is at zero volts, Q8 conducts and discharges C13. When either of the input pins 1 or 2 are low, the microcontroller resets.

External memory for the microcontroller consists of EPROM U14 and RAM U15. The EPROM contains the program that controls the microcontroller functions and holds the algorithm used to analyze the ECG signal. The RAM is used as temporary storage for patient information, serial communication with the Instrument Interface circuit, and as a scratchpad memory for computation.

Microcontroller U17 uses a 16-bit address/data bus for accessing the external memory. Eight bus lines at P3 (0-7) are available for data, and up to 15 lines (P3 0-7 and P4 0-6) can be used for addressing by activating the ALE (address line enable) line. Latch U16 retains the latest address on P3.0-7 when that port is used for data transfer.

#### Instrument Interface

Isolation between the patient and the LIFEPAK 9 Shock Advisory Adapter is provided by the Instrument Interface circuit. This isolation barrier is rated to withstand up to 7500Vac (at 60Hz) with less than 10 $\mu$ A leakage. Commands from the adapter front panel, the Shock Advisory Inhibit, and the Serial Communication are routed through opto-isolators U4 through U7.

The ANALYZE pushbutton on the front panel initiates microcontroller (U17) analysis of the ECG signal in the Analyze Interface circuit. After the microcontroller completes analysis of the ECG signal, the data from the serial communication lines displays on the CRT as messages.

The cathode of opto-isolator U6 connects to the ANALYZE SW line and isolates the ANALYZE pushbutton. Pressing the ANALYZE pushbutton grounds the cathode of U6 and produces a logic low at the output. This transmits to the input of NOR gate U12D. When both the ANALYZE SW line and the Serial Communication line are low, U12D switches high and the microcontroller starts to analyze the ECG signal.

The microcontroller illuminates the ANALYZE LED while it analyzes the ECG signal. When the microcontroller starts ECG signal analysis, it produces a high logic signal at port P1.3. This signal causes Q7 to conduct, producing a low signal output from U7. MOSFET Q5 in turn conducts and provides drive current for the ANALYZE LED.

All communication involving transmission of Display data for the LIFEPAK 9 defibrillator/monitor takes place through the Serial Communication lines at post P2.0 and P2.1 on microcontroller U17. Transistor Q2 amplifies the serial transmit data (TXD) from the LIFEPAK 9 defibrillator/monitor for isolation across U5.

U11F inverts the serial receive data (RXD) while Q6 amplifies the signal. Isolation is provided by U4.

### Microcontroller Inhibit

The disruptive nature of a defibrillator pulse requires that the microcontroller (U17) be inactive during defibrillation. The Microcontroller Inhibit circuit shuts down the Power Supply, forcing the microcontroller into reset until defibrillation is over.

Two conditions must be met before microcontroller activity can be inhibited: the CHARGE LED must be illuminated and BOTH discharge pushbuttons must be pressed simultaneously.

Dual comparator U1 shuts down pulse-width modulator U2 when a defibrillation pulse occurs. The noninverting input of U1A is controlled by the CHG LED through resistor divider R2 and R4; the inverting input of U1A is controlled by both XFER SW lines through resistor divider R3, R1, and R6.

U1A and U1B change states when the charge LED illuminates and both discharge pushbuttons are pressed. Pressing the discharge pushbuttons (XFER SW) switches R1 and R6 in parallel, presenting +2.1V at the noninverting input of U1A. Illumination of the CHG LED presents +2.5V at the inverting input of U1A, forcing the output to ground. U1B responds to the output of U1A by switching high at pin 7 and shuts down pulse-width modulator U2. The microcontroller then resets for the duration of the defibrillator pulse (see Microcontroller Core, page 1-8). RC network C3 and R5 delay the BATT voltage enough to keep from activating the microcontroller too soon after a defibrillation pulse.

---

**Introduction**

This section provides information about the basic operation of the instrument. It is not intended to instruct an operator in the clinical use of the instrument. For clinical use, refer to the separate *Operating Instructions* manual. This section includes information about the Controls and Indicators.

---

**Controls and Indicators**

LIFEPAK 9 shock advisory adapter controls and indicators are identified in Figure 2-1 and described in the corresponding Table 2-1.

**Note:** *Pushbuttons are indicated in CAPITAL LETTERS.*



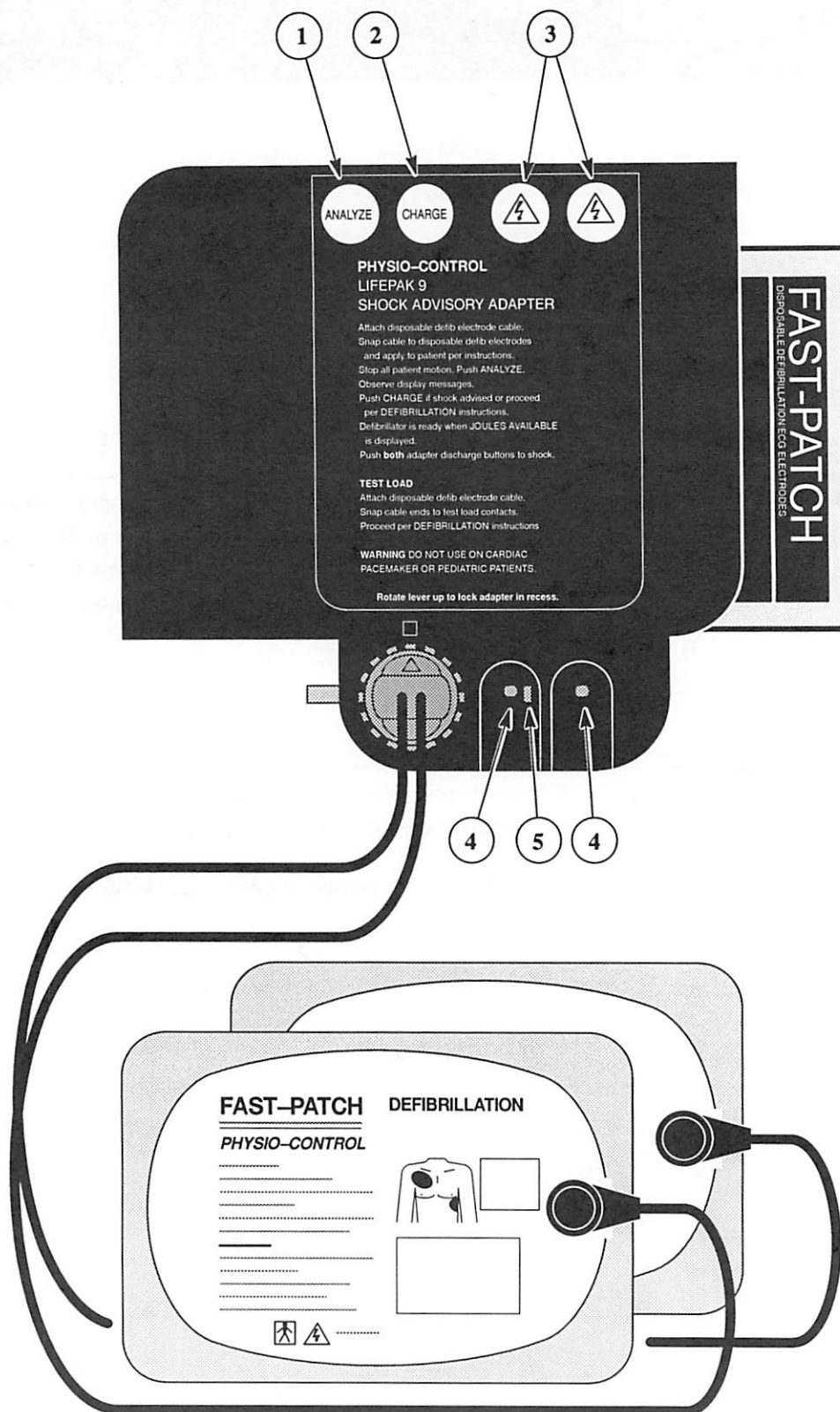


Figure 2-1 Front Panel Controls and Indicators

**Table 2-1 Controls and Indicators**

<b>Item</b>	<b>Control or Indicator</b>	<b>Function</b>
1	ANALYZE	Pushbutton starts heart rhythm (ECG) analysis. Pushbutton indicator LED is on during analysis.
2	CHARGE	Momentary pushbutton starts defibrillator charge cycle. Pushbutton indicator LED flashes while defibrillator is charging; it remains on steadily when charge is reached.
3	SHOCK	Pressing both pushbuttons discharges selected energy into patient.
4	TEST LOAD CONTACTS	Connects the defibrillation electrodes to a 50Ω load in the defibrillator for energy testing.
5	TEST LOAD SWITCH	Signals the defibrillator that an energy test is pending.

---

## Introduction

This section provides two test procedures for the LIFEPAK 9 shock advisory adapter:

- Performance Inspection Procedure (PIP), a closed-case test to confirm instrument functions.
- The Test and Calibration Procedures (TCP) provide more extensive testing plus calibration and may require that the instrument be opened.

---

## Performance Inspection Procedure (PIP)

This section provides a suggested Performance Inspection Procedure (PIP) for the LIFEPAK 9 shock advisory adapter. A checklist is provided for customer convenience and may be copied when needed.

Perform the PIP every six months as a periodic maintenance check and after any repair or calibration. Each test in the PIP should be performed in sequential order. Table 3-1 provides a list of test equipment required for the PIP.

## PIP-Scope and Applicability

This PIP applies to all configurations of the Shock Advisory Adapter. This PIP does *not* apply to the LIFEPAK 9 family of defibrillator/monitor/pacemakers; refer to their respective service manuals for testing information.

## PIP-Definitions

Pushbuttons are indicated in CAPITAL LETTERS,  
Displayed messages are indicated in **BOLD CAPITAL LETTERS**.

## PIP-Requirements

The requirements for test equipment, workstation, and personnel are listed below along with important safety information.

PIP-Required  
Equipment

Performing this PIP requires the equipment listed in Table 3-1. Although specific test instruments are recommended, other test equipment with equivalent specifications may be used.

**Table 3-1 PIP Test Equipment**

Equipment	Specifications	Manufacturer
Defibrillation Cable		Physio-Control PN 804089
ECG paper	Box of three rolls	Physio-Control PN 804700-000
LIFEPAK 9 defibrillator/monitor or LIFEPAK 9P defibrillator/monitor/pacemaker	Calibrated	Physio-Control PN 803800 or 805460
Patient Simulator		Physio-Control PN 803499
Safety analyzer	110Vac Line Voltage: current range 0-2000 $\mu$ A current accuracy $\pm 1\%$ resistance accuracy $\pm 1\%$ 230Vac Line Voltage: 200 $\mu$ A/5% of reading 2000 $\mu$ A/1% of reading resistance accuracy $\pm 1\%$	Dynatech Nevada 232HD or equivalent*  Dynatech Nevada 432HD or equivalent*

\* Equivalent equipment is required to meet the specifications listed in the specifications column.

**WARNING**

**Shock hazard.** The defibrillator stores and delivers hazardous voltages. All test and service personnel must be familiar with this instrument before attempting to perform these procedures.

PIP-Test Equipment  
Verification

All test equipment used in performing the PIP must have a current calibration label affixed to its exterior. The calibration label must be issued by a certified calibration facility.

PIP-Workstation

The ac line power for this workstation must be connected to a grounded power source.

PIP-Personnel

Personnel performing this PIP must be thoroughly familiar with the operation of the LIFEPAK 9 defibrillator/monitor and the Shock Advisory Adapter. In addition, personnel performing this PIP must meet at least one of the following levels of education or experience:

- Associate of applied science degree with a major emphasis in biomedical electronics
- Certificate of technical training in electronics with a major emphasis in biomedical electronics
- Equivalent biomedical electronics experience.

**PIP-Physical Inspection**

Before beginning the PIP-Physical Inspection, be sure to disconnect the ac power cord from the ac power source.

- Perform a complete visual inspection of the LIFEPAK 9 defibrillator/monitor and shock advisory adapter.
- Inspect all controls, indicators, and displays for physical deterioration and proper operation.
- Inspect for cracks, dents, loose or missing hardware, damaged labels, and contamination for foreign substances.
- Inspect the power cord and all cables and accessories for damage, cracks, breaks, bent or broken connector pins, or other signs of wear.

The display flow diagram in Figure 3-1 shows the entire sequence of CRT screens called out in the PIP. Figure 3-1 also defines the priority of the audible tones in the procedure.

Priority 1: A 440Hz and 880Hz tone – a life-threatening condition is imminent and immediate action by the operator is required.

Priority 2: A continuous 698Hz tone – an urgent condition that requires a timely operator response

Priority 3: Three 1046Hz tone bursts – a status change or abnormal condition exists.

**PIP-Analyze**

1. Install the adapter into the LIFEPAK 9 defibrillator/monitor.
2. Connect the defibrillation cable to the adapter and the patient simulator.
3. Press ON to apply power to the patient simulator and set to NSR.
4. Press ON to apply power to the defibrillator/monitor and confirm that the ON LED illuminates.
5. Select **PADDLES** on the defibrillator by pressing LEAD SELECT.
6. Press the adapter ANALYZE pushbutton and verify:
  - The CRT displays **200 JOULES SELECTED**
  - **ANALYZING NOW, STEP BACK**
  - **PADDLES X 1.0**
7. Verify the SYNC LED is not on and a Priority 3 tone sounds.
8. After the adapter has completed analysis (about 10sec), the CRT displays **NO SHOCK ADVISED** and three tones sound.
9. After analysis has timed out (about 20sec), **NO SHOCK ADVISED** is no longer illuminated and the CRT screen is blank.

## **PIP-VF Detection and Shock**

Perform each of the following three tests (VF Detection and Shock, Motion Detection, and Test Load) in sequence. They are software driven and cannot be manually delayed or interrupted. Please read through the entire test instruction before proceeding.

1. Set the simulator to VF and press the adapter ANALYZE pushbutton, illuminating the analyze LED. After analysis is complete (about 10sec), verify:
  - The CRT displays **SHOCK ADVISED!**  
**PUSH CHARGE**
  - A priority one tone sounds.
2. Press the adapter CHARGE pushbutton and verify:
  - The CRT displays **CHARGING**  
**STAND BY**
  - A priority one tone sounds
  - The adapter CHARGE LED flashes
3. When charging is complete (the LED by the CHARGE pushbutton illuminates steadily), verify:
  - The CRT displays **PUSH SHOCK BUTTONS**  
**STAND CLEAR!**
  - Pressing only the right-hand adapter button discharge pushbutton results in no energy transfer; pressing only the left-hand discharge pushbutton results in no energy transfer.
4. Press both adapter discharge buttons and verify:
  - Adapter ANALYZE and CHARGE LEDs are off
  - The CRT displays **200 JOULES SELECTED**

## **Leads Off**

The steps below test whether the patient leads are connected to the patient.

1. With the Patient Simulator still connected, set the simulator to NSR.
2. Press the defibrillator ANALYZE button. Three beeps will sound and the CRT will display;
  - **ANALYZING NOW,**  
**STEP BACK**

3. Disconnect one lead of the defibrillation cable while the defibrillator is still analyzing. Three beeps will sound and the following CRT message will flash:

- **TO ANALYZE:  
CONNECT DEFIB PADS**

4. Reconnect the lead to the Patient Simulator and three beeps will sound and the CRT will display;

- **ANALYZING NOW,  
STEP BACK**

#### **PIP-Motion Detection**

1. Press VF on the patient simulator, then press and hold the MOTION pushbutton to send a simulated motion signal into the instrument.
2. Press ANALYZE and verify:
  - The CRT displays **TO ANALYZE: STOP MOTION**
  - A priority three tone sounds
3. Continue to hold down the MOTION pushbutton an additional 30 seconds and verify:
  - The CRT displays **MOTION DETECTED  
CANNOT ANALYZE**
  - A priority three tone sounds
4. After another 20 seconds, verify the ANALYZE LED is off and the motion message disappears.

#### **PIP-Test Load**

1. Connect the defibrillator cable to the test load contacts and check that a roll of paper is in the recorder.
2. Press CHARGE on the adapter.
3. Press both discharge buttons simultaneously on the adapter and verify:
  - The recorder annotates the appropriate data.
  - The CRT displays **TEST 200 JOULES DELIVERED.**

**PIP-Leakage Current**

Perform an ac leakage check using a safety analyzer with the adapter installed in the LIFEPAK 9 defibrillator/monitor. Check leakage current in accordance with the following standards: AAMI/ANSI (Association for the Advancement of Medical Instrumentation/American National Standards Institute) ES1-1985, AAMI/ANSI DF2-1989, CSA (Canadian Standards Association) C22.2, IEC (International Electrotechnical Commission) 601-1, IEC 601-2-4, and UL (Underwriters Laboratories) 544.

1. Lead Source Current (Patient Cable): 20 $\mu$ A or less
2. Lead Sink Current (Patient Cable): 20 $\mu$ A or less
3. Defibrillation Cable sink current: 100 $\mu$ A or less (typically 55 $\mu$ A)



**PIP Checklist**

Customer: \_\_\_\_\_  
 Date: \_\_\_\_\_ Dept/Location: \_\_\_\_\_  
 Instrument Type: \_\_\_\_\_  
 Model: \_\_\_\_\_ Serial Number: \_\_\_\_\_  
 Frequency: \_\_\_\_\_  
 Last Insp: \_\_\_\_\_  
 Tech. Name/ID: \_\_\_\_\_

Performance Inspection	Pass	Fail	Comments
Physical Inspection	<input type="checkbox"/>	<input type="checkbox"/>	_____
Analyze	<input type="checkbox"/>	<input type="checkbox"/>	_____
VF Detection and Shock	<input type="checkbox"/>	<input type="checkbox"/>	_____
Leads Off	<input type="checkbox"/>	<input type="checkbox"/>	_____
Motion Detection	<input type="checkbox"/>	<input type="checkbox"/>	_____
Test Load	<input type="checkbox"/>	<input type="checkbox"/>	_____
Leakage Current	<input type="checkbox"/>	<input type="checkbox"/>	_____

## Functional Test and Calibration Procedures

Perform the applicable tests in this section if the instrument fails a test in the PIP or if there is a suspected failure in an assembly. Each test may be performed separately from the other tests. Always perform the PIP after completing any tests in this section.

Test and calibration, repair, and component removal should be attempted only by personnel qualified by training or experience. Printed circuit boards (PCBs) which cannot be repaired in the field should be returned to Physio-Control for service.

### WARNING

**Shock hazard.** Do not touch exposed terminals and wires while instrument power is on.

### CAUTION

**Avoid component damage.** Static Sensitive Devices (SSDs). Use the Special Handling Procedures for Static Sensitive Devices described in section 4 to prevent build up of static charge. Refer to Table 5-1 to identify PCB assemblies containing SSDs.

## Servicing Guidelines

Some test and calibration procedures may require opening the instrument case. Disassembly procedures are provided in Section 4.

Perform a close visual inspection before disassembly.

Label each lead or draw a sketch showing the location of cables and wires before removing a PCB or mechanical assembly for repair or replacement.

## TCP-Scope and Applicability

This TCP applies to all configurations of the Shock Advisory Adapter. This PIP does *not* apply to the LIFEPAK 9 family of defibrillator/monitor/pacemakers; refer to their respective service manuals for testing information.

## TCP-Definitions

Pushbuttons are indicated in CAPITAL LETTERS,  
Displayed messages are indicated in **BOLD CAPITAL LETTERS**.

## TCP-Requirements

The following are *minimum* requirements:

### TCP-Equipment Requirements

Instruments necessary for testing of the LIFEPAK 9 shock advisory adapter are listed in Table 3-2. Although specific, commercially available test instruments are recommended, other test equipment with specifications equivalent to those listed may be used.

**Table 3-2 Test and Calibration Test Equipment**

<b>Equipment</b>	<b>Specifications</b>	<b>Manufacturer</b>
Digital Multimeter (DMM)	Range: 0 to 20V, 0-10A Accuracy: 1.5% dc current 0.3% dcV	Fluke Model 77
Oscilloscope	Bandwidth: dc to 50MHz	Tektronix Model 2225 or equivalent
Signal Generator	Output Waveform: Sinusoidal	Krohn-Hite Model 5400A

**TCP-Setup**

Take the rear cover off the adapter (see Section 4). Lay the adapter flat in front of the LIFEPAK 9 defibrillator/monitor with the paddles removed from the paddle well. Pull out the High Voltage Connector Cable from the adapter and connect it to the paddles connector on the LIFEPAK 9 defibrillator/monitor.

**TCP-Power Supply and Oscillator Checks**

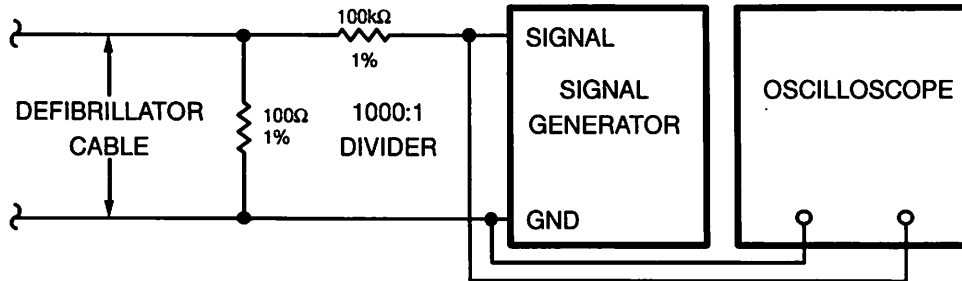
No calibration is needed for the Power Supply and Oscillator checks in Table 3-3. Use the lead of VSP1 which is closest to TP3 for nonisolated ground; use the lead of VSP1 closest to TP6 for isolated ground.

**Table 3-3 Power Supply and Oscillator Checks**

<b>Location</b>	<b>Signal Name</b>	<b>Tolerance</b>
<b>Nonisolated Ground</b>		
U2 pin 14	Power Supply Switching Signal	62.5 $\mu$ s to 45.5 $\mu$ s (16kHz to 22kHz)
TP1	+5V Nonisolated supply	+4.75V to +5.25V
<b>Isolated Ground</b>		
TP7	+5V Isolated supply	+4.75V to +5.25V
TP4	+8V Isolated supply	+7.6V to +8.4V
TP8	VREF Isolated supply	+4.75V to +5.25V

**TCP-Preamp Gain**

Steps 1 and 2 below test the output of U18 ECG amplifier hybrid. Set the output of the function generator to produce a 1V p-p, 10Hz sine wave. Connect the frequency generator to the adapter using a 1000:1 voltage divider (Figure 3-2) to keep the 1mV test signal accurate and stable.



**Figure 3-2 Test Signal Setup**

1. Connect the oscilloscope ground to U12 pin 7. Turn on the frequency generator.
2. Verify the signal at TP9 is 4V p-p  $\pm 0.2\text{V}$ . Turn off the frequency generator.

---

## Introduction

This section provides the following information:

- Special Handling Procedures for Static Sensitive Devices
- Disassembly Procedures
- Inspection Techniques
- Tools and Materials for Cleaning and Repair
- Cleaning Procedures
- Printed Circuit Board Repair Precautions
- Preparation for Storage or Shipping.


---

## Special Handling Procedures For Static Sensitive Devices (SSDs)

Many electronic semiconductor devices such as MOS ICs, FETs, optical isolators, or film resistors can be damaged by the discharge of static electricity. It is very common for anyone to build up static charges, especially when wearing synthetic clothes, and to transfer this charge to any object touched. Such a discharge can damage or destroy Static Sensitive Devices (SSDs). In most cases, the discharge is not even perceptible to the person at fault.

In order to help prevent damage to SSDs due to static discharge, observe the following precautions when performing any open-case test, maintenance, or repair procedures:

### Look for SSD Symbol

Note that SSDs such as PCBs are indicated in this service manual with the following warning: 

### Use Static-Dissipative Mat

Always perform repair or maintenance on a static-dissipative mat connected to earth ground.

**Wear Wrist Strap**

Always wear a conductive wrist strap connected to the mat and to ground except when working on energized equipment or when discharging high voltage circuits. The strap must be snug enough to make good contact against bare skin.



**⚠ WARNING**

**Shock hazard.** Remove the wrist strap when working on energized equipment or when discharging high voltage circuits.

**Transport and Store PCBs Properly**

Transport and store PCBs in anti-static racks or inside conductive bags. Label the package containing the PCBs as static-sensitive.

**Keep Work Area Static-Free**

Keep static-generating products such as styrofoam cups or trays away from the work area. Connect all electrical equipment such as soldering irons and test equipment to ground through a three-prong plug.

**Test Work Area Routinely**

Test all the anti-static parts of the work area (mat, straps, cables) routinely. Keep a log of the test results.



---

**Disassembly Procedures**

The following procedures provide a logical sequence for disassembling the major components of the Shock Advisory Adapter. Separate or disassemble only to the extent required. Parenthetical numbers refer to item numbers in the final assembly parts list (beginning on page 5-4) and Figure 5-1 .

**Case Separation**

1. Lay the Shock Advisory Adapter face down on a work surface with the five cover screws visible. Remove the five screws (19).
2. Separate the Rear Case (4) by lifting it straight up, freeing it from the High Voltage Connector Plug.

**SAS Adapter PCB Removal**

After separating the cases:

1. Remove the High Voltage Connector Plug by disconnecting J7 and J5.
2. Free the SAS Adapter PCB Assembly by disconnecting J4 and J1.



**PCB Repair Precautions**

The SAS Adapter PCB Assembly in the adapter is a multilayer PCB. Multilayer PCBs are not repaired easily. It consists of alternate layers of conductive patterns and insulating material bonded together and interconnected with plated-thru holes. The internal layers and connection points are quickly damaged by too much heat, rendering the entire PCB useless. It is therefore recommended that all multilayer PCBs be returned to Physio-Control for repair or replacement.

**Inspection Techniques**

When servicing or repairing the instrument, begin with a visual inspection. When a failure is found, look for other peripheral damage.

**Exterior Inspection**

Visually inspect the entire instrument for wear, corrosion, deterioration, and damage resulting from extreme temperatures or dropping. Lift and turn the instrument upside down while listening for loose hardware.

**Interior Inspection**

Table 4-1 lists the major hardware components of the instrument, possible problems, and recommended corrective actions.

**Table 4-1 Inspection Techniques**

<b>Hardware</b>	<b>Problem</b>	<b>Corrective Action</b>
Chassis, covers, and brackets	Warped, bent, damaged surface, or missing hardware	Replace
Components (mechanical and electrical)	Loose mountings Broken, or damaged leads Deteriorating or leaking	Repair Replace Replace
Connector pins	Bent Loose or corroded	Straighten (if slight) Replace
Nameplate, labels, and decals	Illegible	Replace if damaged
PCB surfaces*	Charred, cracked, or brittle	Replace PCB
Screws and nuts	Loose or cross-threaded	Tighten or replace
Terminals and connections	Improperly installed Missing or worn Failed solder connections	Install correctly Replace Resolder (if not damaged) or replace
Wire insulation and tubing	Deteriorated, worn, pinched, or damaged	Replace

\* Some discoloration of the PCB surface can be expected due to high operating temperatures of some components.

## Tools and Materials for Cleaning and Repair

Table 4-2 lists recommended tools, materials, and chemicals required for cleaning and repair. Although specific items are recommended in Table 4-2, other tools and materials with specifications equivalent to those listed may be used.

**Table 4-2 Tools and Materials for Cleaning and Repair\***

Product	Description
Static-protected work area	Grounded conductive surface and wrist strap
Crocus cloth	
Isopropyl alcohol	
Acid brush	
Cotton swabs	
Vacuum cleaner	
Soft-bristle brush	Nonmetallic
Cloth	Clean and lint-free
Compressed air	Clean and dry (60 psi, max.)
Electronic Supply Dealers	
X-32B and Xersin <sup>®</sup> solder Multicore Westbury, NY 11590	Low flux, no cleaning necessary
5-Minute <sup>®</sup> Epoxy Devcon Danvers, MA 01923	Adhesive
Tak Pak <sup>®</sup> Loctite Newington, CT 06111	Adhesive and 710 accelerator
Silverstat Edsyn Van Nuys, CA 91406	Low-static desoldering tool
Soldapullt <sup>®</sup>	Model AS196
* This symbol <sup>®</sup> indicates a registered trademark.	

## Cleaning Procedures

Clean the instrument as needed during maintenance or after disassembly and repair.

### Exterior Cleaning

The Shock Advisory Adapter and its cables should be cleaned by wiping the surface with any of the following solutions:

- Soap and water
- Quaternary ammonium compounds



Contact infection control resources for any specific questions regarding cleaning procedure or protocol.

- Do not immerse or soak cable or device.
- Do not use bleach, bleach dilution, isopropyl alcohol, or phenolic compounds.
- Do not steam or gas sterilize.
- Do not autoclave this device or accessories unless otherwise specified.

**⚠ WARNING**

**Shock or fire hazard.** Do not immerse any portion of this device in water or other fluids. Avoid spilling any fluids on device or accessories.

**Interior Cleaning**

Follow disassembly procedures (beginning on page 4-2) to access instrument interior.

**⚠ WARNINGS**

**Chemical fire hazard.** Observe shop safety and fire precautions. Store solvents and solvent-soaked rags in approved containers. Refer to manufacturers instructions on containers for recommended firefighting procedures. Keep firefighting equipment available.

**Personal safety hazard.** Ventilate work area when using solvents. Observe manufacturer warnings regarding personnel safety and emergency first aid. Keep first aid equipment available when using chemicals.

**⚠ CAUTIONS**

**Avoid component damage.** Use SSD handling procedures when working on static sensitive devices (SSDs).

**Avoid damaging components.** Do not use chemicals or solvents to clean transformers or inductors. To do so may remove varnish from the wire coils rendering the component useless. Solvents neutralize adhesives resulting in tape separation from the windings.



ATTENTION

1. Brush surfaces and parts with a nonmetallic soft-bristle brush. Remove loosened dirt and dust using dry low-pressure compressed air (60 psi) or a vacuum cleaner.
2. Wipe metal surfaces with a soft, nonabrasive cloth dampened with isopropyl alcohol.

**⚠ CAUTION**

**Prevent nameplate damage.** Do not use abrasive cleaners or solvents to wipe nameplates and labels—the nameplate information may disappear.

3. Wipe surfaces of nameplates and labels with a clean, dry cloth.

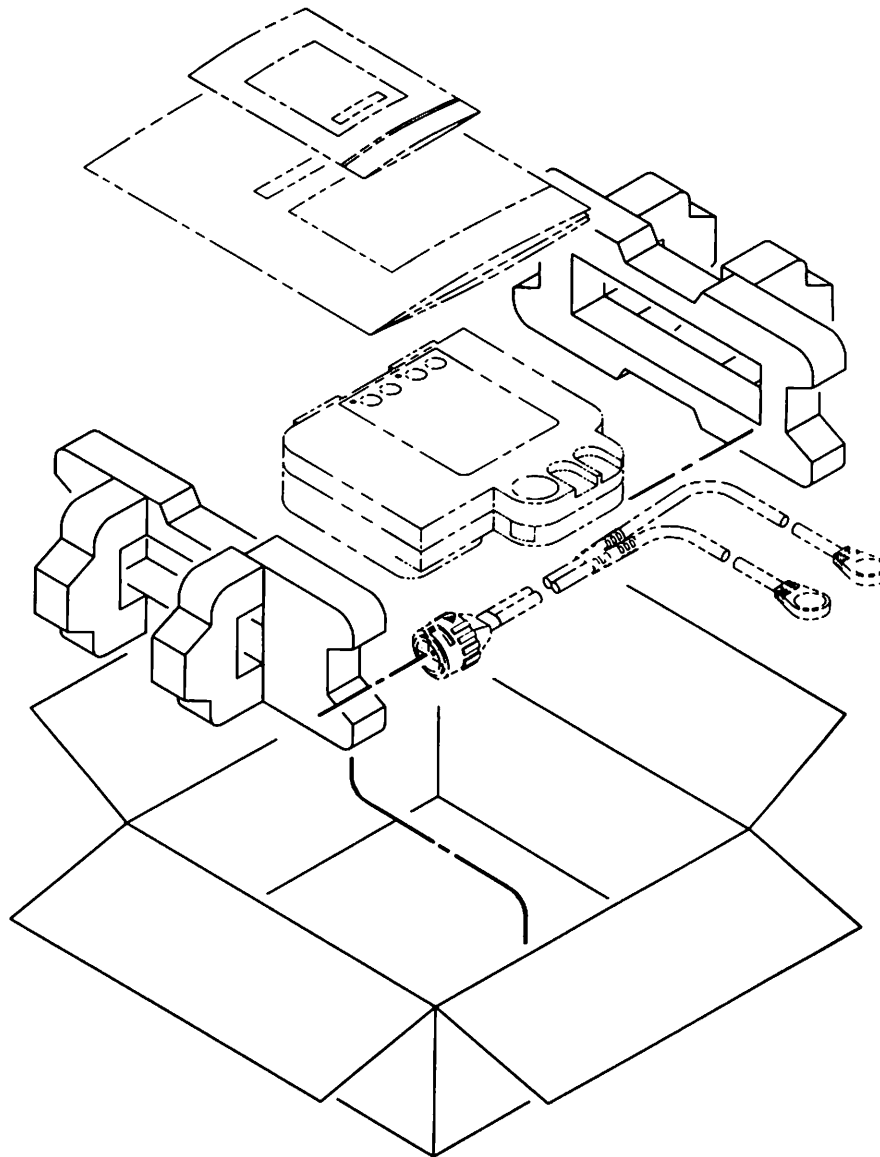
**⚠ CAUTION**

**Avoid equipment damage.** Do not use solvents to clean plastic parts.

4. Clean surfaces of plastic parts with a mild soap and water solution. Dry with a clean cloth.
5. Clean soldering surfaces with a nonmetallic, soft-bristle brush dipped in alcohol then wipe with absorbent cloth. Air dry 10 minutes or use low-pressure compressed air (60 psi) before soldering.

**Shipping Assembly**

Save the original shipping box and packing material for later use. If the Shock Advisory Adapter must be shipped to the service center or factory, the special packaging is required to prevent shipping damage. Refer to Figure 4-1 when repacking.



**Figure 4-1 LIFEPAK 9 shock advisory adapter Shipping Assembly**

---

## Introduction

This section includes lists of replaceable parts, component layouts or exploded views, and schematic diagrams for each major assembly of the LIFEPAK 9 shock advisory adapter. This information is provided to assist in troubleshooting and repair. Table 5-1 lists the figure and page number of the major assemblies for the defibrillator/monitor. Table 5-2 lists standard reference designators for components. Supplies and accessories are listed in Table 5-3.

## Parts List

Use parts lists to identify *replaceable* parts. The format for each list is the same:

**Ref:** This column contains the reference designators or the assigned item numbers of replaceable parts. Reference designators are abbreviated (see Table 5-2) and are listed alphanumerically by this abbreviation. Assigned item numbers are listed numerically, starting with 2. The number in the heading of this column indicates the figure to which the parts list corresponds.

**Part Number:** Physio-Control Corporation part number is listed in this column. Part ordering information is provided on page 5-2.

**Description:** Descriptive information for a part that is used more than once refers to the initial listing with a "Same as \_\_\_" citation. This citation may also list a component value when necessary. Static Sensitive Devices (SSDs) are identified in this column by this symbol:



For information about proper handling of SSDs during repair or replacement, refer to Section 4, page 4-1.

**Use Code:** Different hardware configurations and their corresponding letter codes are listed at the beginning of each parts list. Subsequent use

of any letter code indicates which part is used in a particular configuration. A blank in this column indicates that the part is used in all configurations.

**Qty:** The quantity column specifies the *total* quantity used for each part number listed. The abbreviation REF indicates a major assembly or subassembly.

### **Component Layouts or Exploded Views**

Use component layouts or exploded views to locate parts. The reference designator or assigned item number on the drawing corresponds to the REF column entry on the parts list.

### **Schematic Diagrams**

Schematic diagrams depict circuit function and signal flow. Signal names, pin numbers, and polarities are labeled on the schematics as well as reference designators and values from the parts list.

- In general, signal flow is from left to right
- Circuit names on schematics correspond to descriptions in Section 1
- ICs marked with a ✱ are detailed in Section 6
- To/From labels correspond to connections shown on the interconnect diagram.

This manual documents the revision levels of the assemblies which were in production at the time of publication. Since the time of publication, it is possible that modifications to the assemblies have occurred which are not documented in this manual. For assistance in obtaining updated information contact your local Physio-Control representative.

---

### **How to Order Parts**

To order parts, contact your local Physio-Control representative. Give the instrument part number and serial number located on the bottom panel of your instrument. Then specify all assembly numbers, part numbers, reference designations, and descriptions. Different parts may be substituted by Physio-Control to reflect modifications and improvements of instrument circuitry.

**Table 5-1 LIFEPAK 9 Shock Advisory Adapter Major Assemblies**

Ref	Part Number	Nomenclature	Fig. No.	Page No.
REF	803732-00	LIFEPAK 9 shock advisory adapter Final Assembly	5-1	5-7
	803732	Interconnect Diagram	5-2	5-8
A1	803779	SAS Adapter PCB Assembly ▲	5-3	5-13
A2	—	Chassis/Harness		
W1	803774-01	Pushbutton Wire Harness	5-4	5-17
W2	803774-02	Test Load Switch/PCB Wire Harness	5-5	5-18
W3	803774-03	Test Load High Voltage Wire Harness	5-6	5-18
W4	803774-04	Test Load High Voltage Wire Harness	5-7	5-19
W5	803756	High Voltage Connector Cable Assembly	5-8	5-20

**Table 5-2 Reference Designator Key**

Designator	Description	Designator	Description
A	Main Assemblies	RN	Resistor Network
C	Capacitor	RV	Varistor
CR or D	Diode	RT	Thermistor
F	Fuse	S	Switch
H	Heat Sink	T	Transformer
J	Jack Connector	TP	Test Point
JP	Jumper Wire	U	IC (Integrated Circuit)
K	Relay	VSP	Voltage Surge Protector
L	Inductor	W	Wire Harness
P	Plug Connector	Y	Crystal
Q	Transistors	XU	IC Socket
R	Resistor		

**Table 5-3 Accessories and Supplies**


Description	Part Number
Defibrillator Cable	806421
FAST-PATCH disposable defibrillation electrodes	804545
Operating Instructions	803755

5-1 Ref	Part Number	Description	Use Code	Qty
		<b>Shock Advisory Adapter Final Assembly:</b>		<b>REF</b>
	803732-00	English, Domestic, 60Hz	A	REF
	803732-01	French, International, 50Hz	B	REF
	803732-02	German, International, 50Hz	C	REF
	803732-03	Spanish, International, 50Hz	D	REF
	803732-04	Spanish, Domestic, 50Hz	E	REF
	803732-05	French, Domestic, 50Hz	F	REF
	803732-06	French, CSA, 60Hz	G	REF
	803732-07	English, CSA, 60Hz	H	REF
	803732-08	English, International, 50Hz	I	REF
	803732-09	Spanish, International, 60Hz	J	REF
	803732-10	Portuguese, International, 50Hz	K	REF
	803732-11	Italian, International, 50Hz	L	REF
	803732-12	Swedish, International, 50Hz	M	REF
	803732-13	English, Domestic, 60Hz	N	REF
	803732-14	French, International, 50Hz	O	REF
	803732-15	German, International, 50Hz	P	REF
	803732-16	Spanish, International, 50Hz	Q	REF
	803732-17	Spanish, Domestic, 50Hz	R	REF
	803732-18	French, Domestic, 50Hz	S	REF
	803732-19	French, CSA, 60Hz	T	REF
	803732-20	English, CSA, 60Hz	U	REF
	803732-21	English, International, 50Hz	V	REF
	803732-22	Spanish, International, 60Hz	W	REF
	803732-23	Portuguese, International, 50Hz	X	REF
	803732-24	Italian, International, 50Hz	Y	REF
	803732-25	Swedish, International, 50Hz	Z	REF
A1	803779-05	SAS Adapter PCB Assembly, 60Hz ▲	A,G,H,J,NT,U,W,	1
	803779-06	SAS Adapter PCB Assembly, 50Hz ▲	B-F, I,K-M,O-S,V,X-Z	1
W1	803774-01	Pushbutton Switch Wire Harness		1
W2	803774-02	Test Load Switch/PCB Wire Harness		1
W3	803774-03	Test Load High Voltage Wire Harness		1
W4	803774-04	Test Load High Voltage Wire Harness		1

5-1 Ref	Part Number	Description	Use Code	Qty
W5	803756-10	High Voltage Connector Cable Assembly		1
2	200536-001	Cable Tie, Nylon, 0.10 W x 4 L (not shown, used on W1 and W5)		3
3	803719-00	Cap, Isolation, Electrode		2
4	803738-13	Case, front, with inserts	N-Z	1
	803738-10	Case, front, with inserts	A-M	1
5	803751-01	Case, rear		1
6	803750-00	Cover, Interior		1
7	805532-01	Fastener, Plate		1
8	803765-00	Insulator, Pin Connector, Electrode		2
9	803752-30	Label, Adapter, English	A,H,I,N,U,V	1
	803752-32	Label, Adapter, French	B,F,G,O,S,T	1
	803752-34	Label, Adapter, German	C,P	1
	803752-36	Label, Adapter, Spanish	D,E,J,Q,R,S	1
	803752-39	Label, Adapter, Portuguese	K,X	1
	803752-41	Label, Adapter, Italian	L,Y	1
	803752-43	Label, Adapter, Swedish	M,Z	1
10	803731-13	Label, Serial Number, English, Domestic	A,N	1
	803731-14	Label, Serial Number, French, International	B,O	1
	803731-17	Label, Serial Number, Spanish, Domestic	E,R	1
	803731-18	Label, Serial Number, French, Domestic	F,S	1
	803731-19	Label, Serial Number, French, CSA	G,T	1
	803731-20	Label, Serial Number, English, CSA	H,U	1
	803731-21	Label, Serial Number, English, International	I,V	1
	803731-27	Label, Serial Number, Portuguese, International	K,X	1
	803731-29	Label, Serial Number, Italian, International	L,Y	1
	803731-33	Label, Serial Number, Swedish, International	M,Z	1
	803731-35	Label, Serial Number, German, International	C,P	1
	803731-40	Label, Serial Number, Spanish, International	D,J,Q,W	1
11	201820-007	LED, HLMP-1440, Yellow, LED 2		1
12	201820-008	LED, HLMP-1540, Green, LED 1		1
13	201508-003	Nut, Kep, Locking, #6-32		4
14	803780-02	Pin, Connector, Electrode, Adapter		2
15	803725-03	Plate, Test Load, Adapter		2
16	802935-10	Pushbutton, Paddle, Analyze, Domestic	A,H,I,N,U,V	1



5-1 Ref	Part Number	Description	Use Code	Qty
	802935-11	Pushbutton, Paddle, Analyze, French/German	B,C,F,G,O,P,S,T	1
	802935-12	Pushbutton, Paddle, Analyze, Spanish	D,E,J,Q,R,W	1
	802935-20	Pushbutton, Paddle, Analyze, Italian	L,Y	1
	802935-21	Pushbutton, Paddle, Analyze, Portuguese	K,X	1
	802935-22	Pushbutton, Paddle, Analyze, Swedish	M,Z	1
17	802935-05	Pushbutton, Paddle, Charge, Domestic/French	A,B,F-I,N,O,S-V	1
	802935-06	Pushbutton, Paddle, Charge, German	C,P	1
	802935-07	Pushbutton, Paddle, Charge, Spanish	D,E,J,K,Q,R,W,X	1
	802935-18	Pushbutton, Paddle, Charge, Italian	L,Y	1
	802935-19	Pushbutton, Paddle, Charge, Swedish	M,,Z	1
18	802935-08	Pushbutton, Paddle, Discharge, Domestic	A,E-H,N,R-U	2
	802935-09	Pushbutton, Paddle, Discharge, International	B-D,I,J-M,O-Q,V,W	2
19	201874-236	Screw, Pan Head, 6-32 x 0.750 L		5
20	201874-001	Screw, Pan Head, 6-32 x 0.250 L		1
21	202253-506	Screw, Pan Head, 2-56 x 0.375 L		2
22	201625-173	Spring, Compression, 0.240 OD, 0.562 L		2
23	803781-01	Switch, Test Load		1
24	200283-003	Tubing, Heatshrink, Red, 0.125 ID		A/R
25	201575-004	Washer, Lock, #6 x 0.288 OD x 0.018 T		2

TYPE	IC NUMBER	LOCATION	REF. DES.
Microcontroller 	80C196KB	Main (A1)	U17

**FUNCTIONAL DIAGRAM**

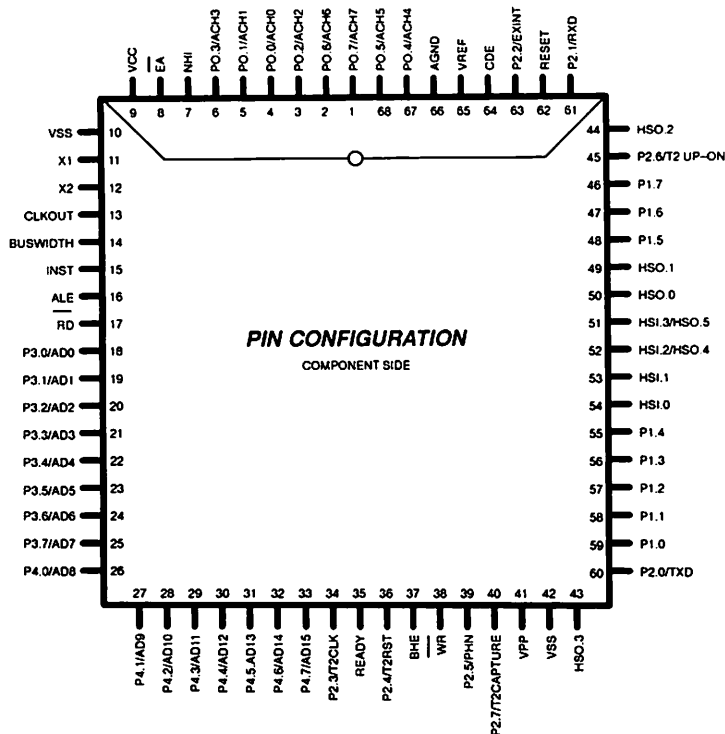
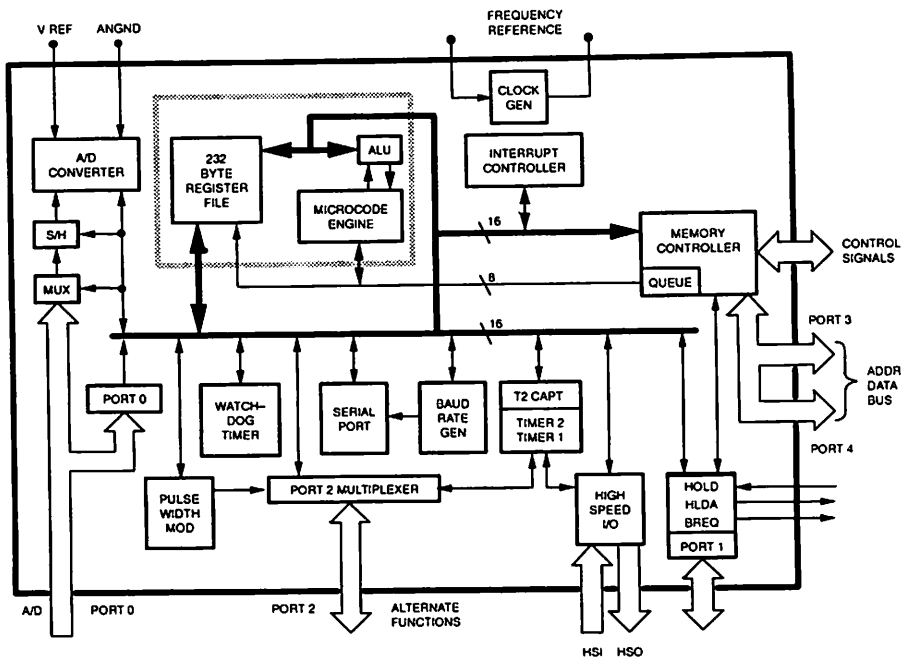
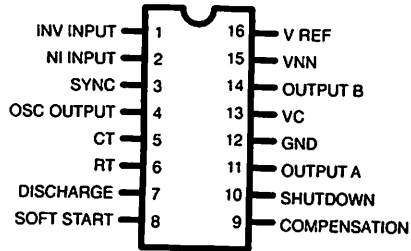


Figure 6-3 Microcontroller

TYPE	IC NUMBER	LOCATION	REF. DES.
Pulse-Width Modulator	3525	Main (A1)	U2

**PIN CONFIGURATION**



**BLOCK DIAGRAM**

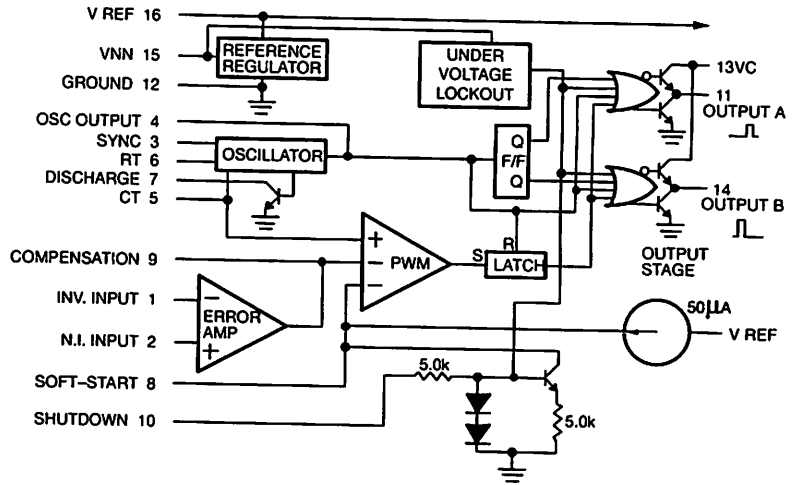

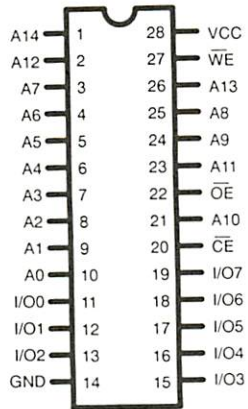


Figure 6-4 Pulse-Width Modulator

TYPE	IC NUMBER	LOCATION	REF. DES.
RAM 	62256LP12SL	Main (A1)	U15

**PIN CONFIGURATION**



**FUNCTIONAL DIAGRAM**

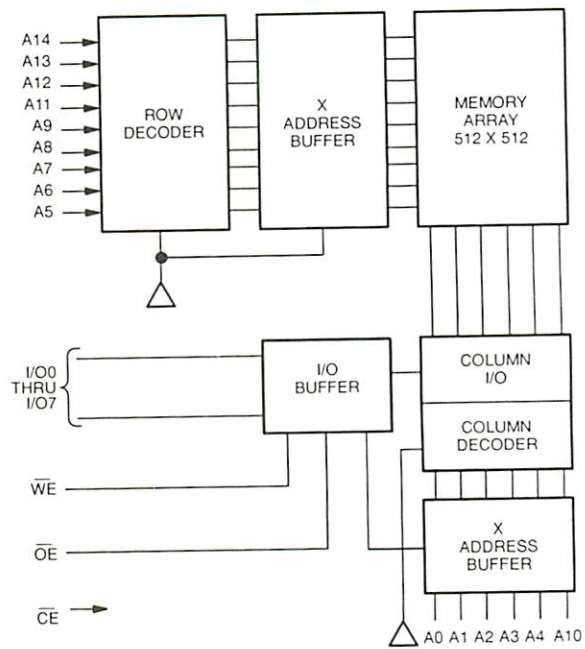


Figure 6-5 RAM

# Component Reference

6

## Introduction

This section contains component diagrams for integrated circuits selected from the PCB assembly schematics. Each figure contains some or all of the following information as an aid in circuit analysis and troubleshooting:

- Pin Configuration
- Function Table
- Block Diagram.

## Caution

**Avoid Component Damage.** Static Sensitive Devices (SSDs) require special handling procedures to prevent build up of static charge without providing hazardous connections to the operator. Refer to Table 5-1, page 5-3, to identify PCB assemblies containing SSDs.

**Table 6-1 Component Reference Diagrams**
























Assembly	Ref Des.	IC Number	Type	Fig No.	Page No.
Display (A11)	U101	TDA1170N	Deflection Circuit	6-9	6-7
	U201	TL494CN	Voltage Regulator	6-27	6-16
Interconnect (A5)	U1 	74HC238	Decoder	6-8	6-6

Table 6-1 Component Reference Diagrams

Assembly	Ref Des.	IC Number	Type	Fig No.	Page No.
Main (A1)	U1,U30 	63B03Y	Microprocessor	6-17	6-11
	U3 		Gate Array, Recorder	6-16	6-10
	U4 	4040	Counter	6-5	6-5
	U5	3525A	Modulator, Pulse-Width	6-18	6-11
	U10	NCM031C	Oscillator	6-21	6-13
	U11,U12, U15 	74HCT244	Buffer	6-1	6-3
	U13,U21, 	HM62256LP-12	Static RAM, 32k x 8	6-24	6-14
	U22 	27C256	EPROM	6-10	6-7
	U16 	74HC74	Flip-Flop, D-Type	6-11	6-8
	U19,U20 	74HCT374	Flip-Flop, D-Type	6-12	6-8
	U25 	74HCT138	Decoder	6-7	6-6
	U26 	74HC4538	Multivibrator	6-20	6-12
	U28A, U28B 	DS1235Y	Smartwatch RAM	NO TAG	NO TAG
	U29 		Gate Array, Display	6-15	6-10
	U31 	74HC221	Multivibrator	6-19	6-12
	U32 	74HC161	Counter	6-6	6-5
	U33 	74HC174	Flip-Flop, D-Type	6-13	6-9
	U36 	74HC76	Flip-Flop, J-K	6-14	6-9
	U40,U43 	DG, DG302	Switch, Analog	6-25	6-15
	U41,U42 	DG509	Switch, Analog	6-26	6-15
Power Conversion (A3)	U3	2843N	Regulator, Pulse-Width	6-23	6-14
	U9 	TLC1541	Converter, A/D	6-3	6-4
	U18 	7541	Converter, D/A	6-4	6-4
	U19,U20 	74HC164	Register, Shift	6-22	6-13

TYPE	IC NUMBER	LOCATION	REF. DES.
Buffer 	74HCT244	Main (A1)	U11, U12, U15

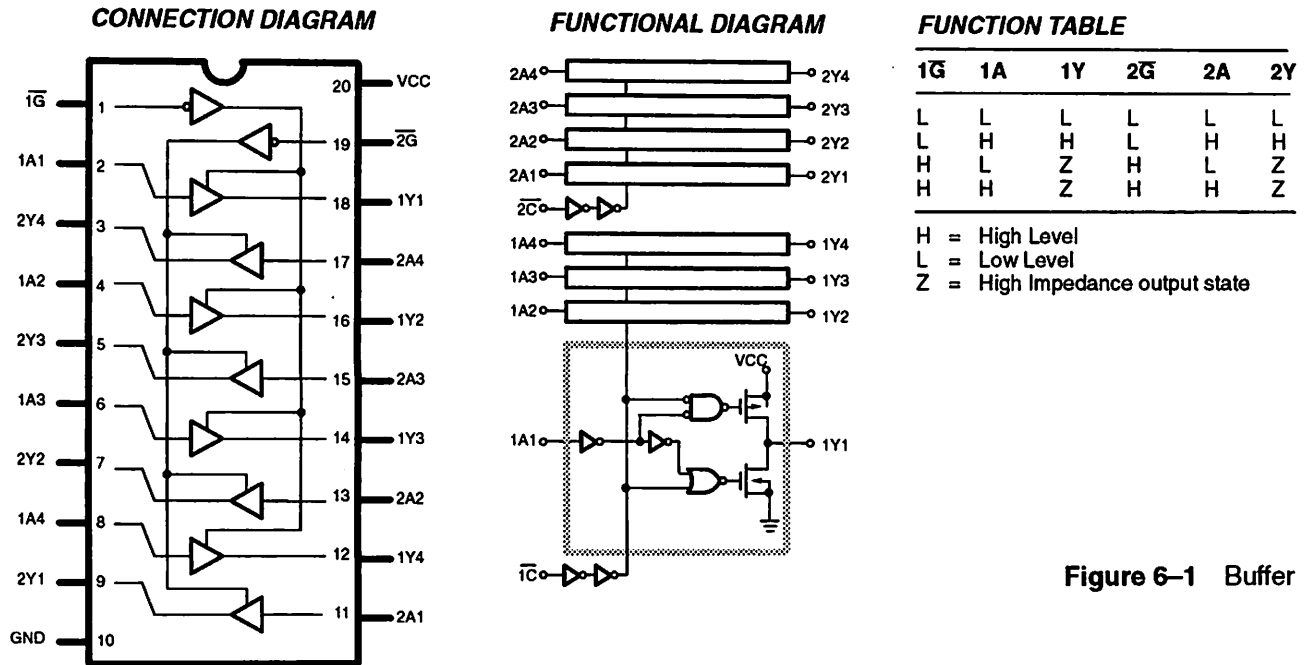
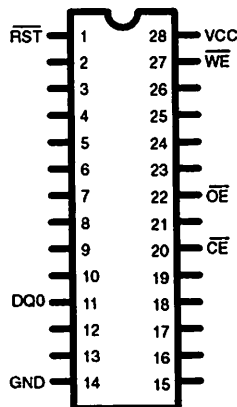


Figure 6-1 Buffer


TYPE	IC NUMBER	LOCATION	REF. DES.
Smartwatch RAM	DS1235Y	Main (A1)	U28A, U28B

**PIN CONFIGURATION**



NOTE: ALL PINS PASS THROUGH EXCEPT PINS 20 AND 28

Figure 6-2 Smartwatch RAM

TYPE	IC NUMBER	LOCATION	REF. DES.
Converter, A/D 	TLC1541	Power Conversion (A3)	U9

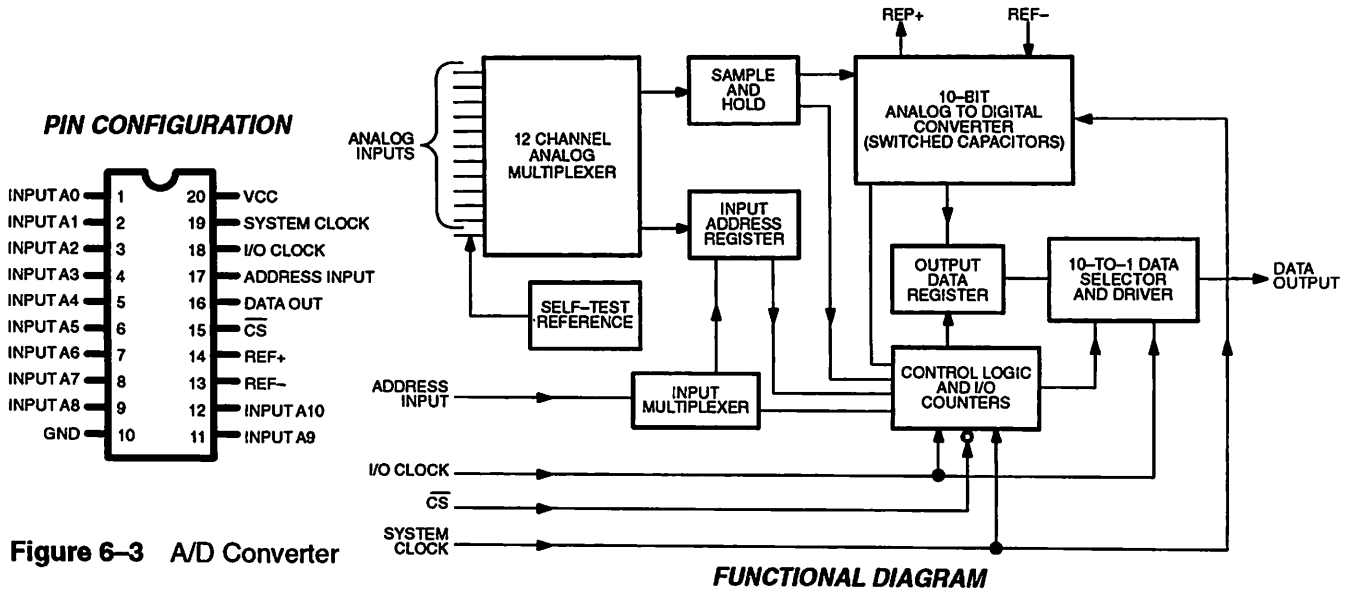

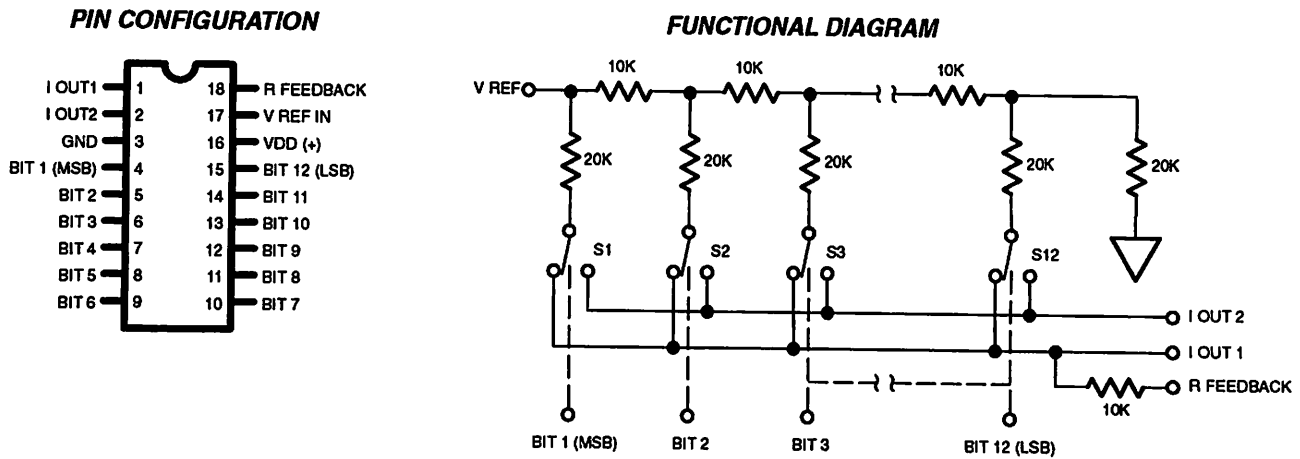


Figure 6-3 A/D Converter


TYPE	IC NUMBER	LOCATION	REF. DES.
Converter D/A 	7541	Power Conversion (A3)	U18

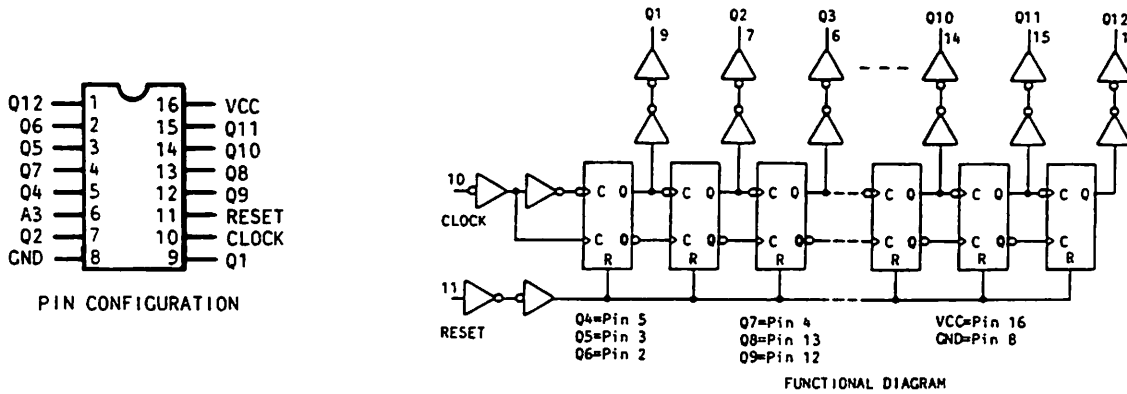




LOGIC: A SWITCH IS CLOSED TO I OUT 1 FOR ITS DIGITAL INPUT IN A "HIGH" STATE.

Figure 6-4 D/A Converter




TYPE	IC NUMBER	LOCATION	REF. DES.
Counter 	4040	Main (A1)	U4

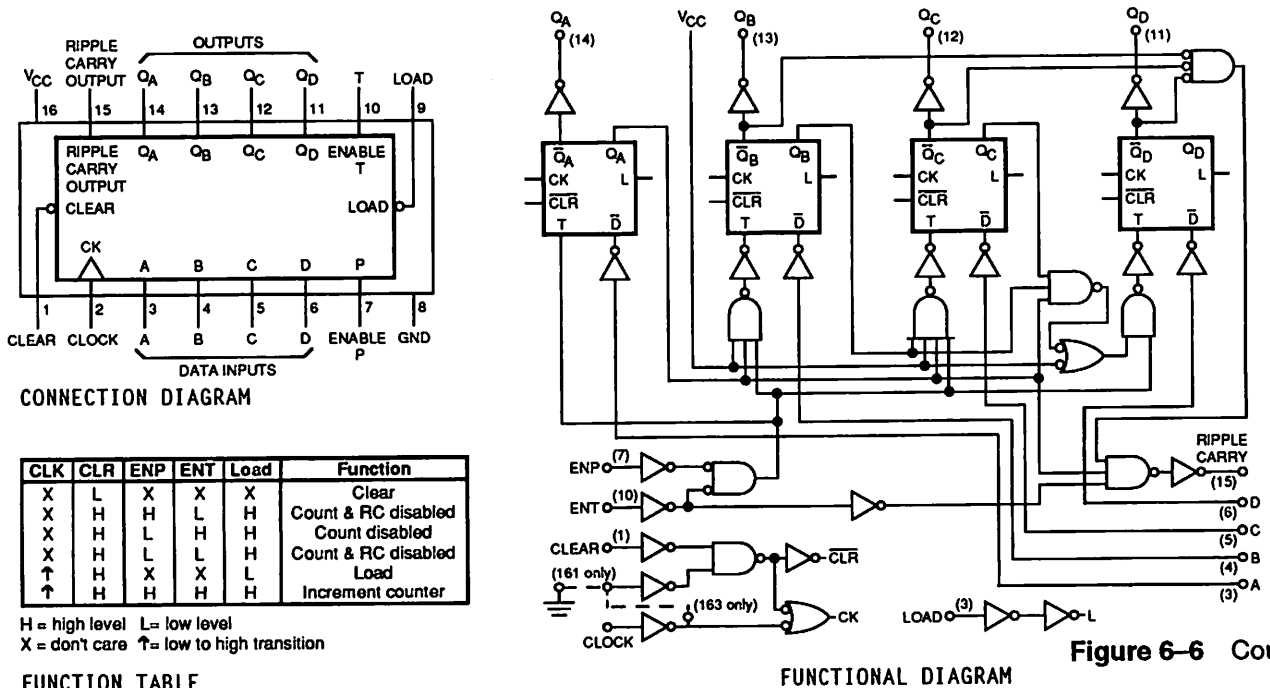


CLOCK	RESET	OUTPUT STATE
	0	No Change
	0	Advance to next state
X	1	All Outputs are low


X = Don't Care

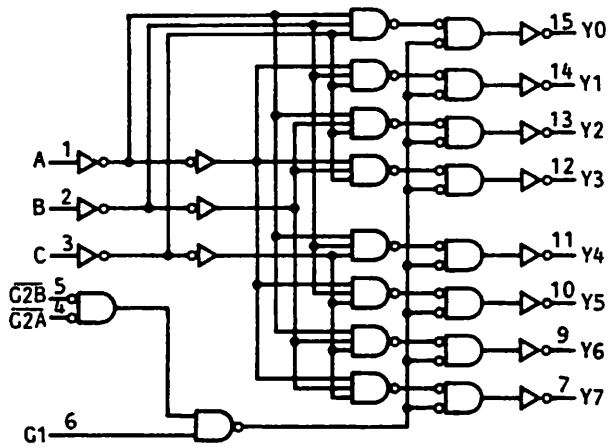
FUNCTION TABLE **Figure 6-5 Counter**

TYPE	IC NUMBER	LOCATION	REF. DES.
Counter 	74HC161	Main (A1)	U32

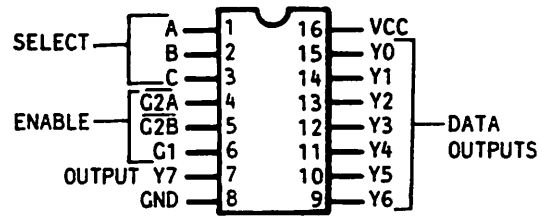


**Figure 6-6 Counter**

TYPE	IC NUMBER	LOCATION	REF. DES.
Decoder 	74HCT138	Main (A1)	U25



FUNCTIONAL DIAGRAM



PIN CONFIGURATION


INPUTS		OUTPUTS									
ENABLE	SELECT	Y0	Y1	Y2	Y3	Y4	Y5	Y6	Y7		
G1	G2*	C	B	A							
X	H	X	X	X	H	H	H	H	H	H	H
L	X	X	X	X	H	H	H	H	H	H	H
H	L	L	L	L	L	H	H	H	H	H	H
H	L	L	L	H	H	L	H	H	H	H	H
H	L	L	H	L	H	H	L	H	H	H	H
H	L	L	H	H	H	H	L	H	H	H	H
H	L	H	L	L	H	H	H	H	L	H	H
H	L	H	L	H	H	H	H	H	L	H	H
H	L	H	H	L	H	H	H	H	H	L	H
H	L	H	H	H	H	H	H	H	H	H	L

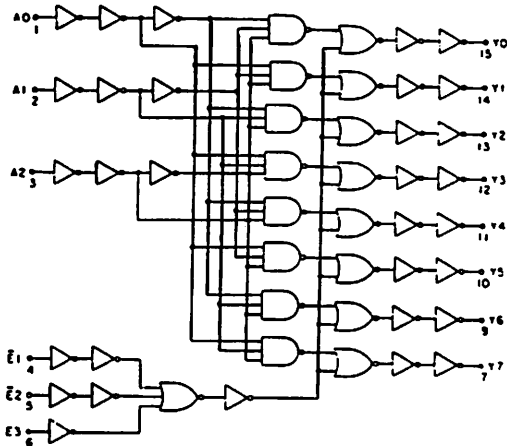
\*G2 = G2A + G2B

H = HIGH LEVEL, L = LOW LEVEL, X = DON'T CARE

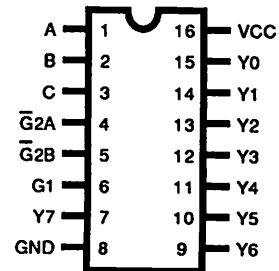
FUNCTION TABLE

Figure 6-7 Decoder

TYPE	IC NUMBER	LOCATION	REF. DES.
Decoder 	74HC238	Interconnect (A5)	U1



FUNCTIONAL DIAGRAM



PIN CONFIGURATION

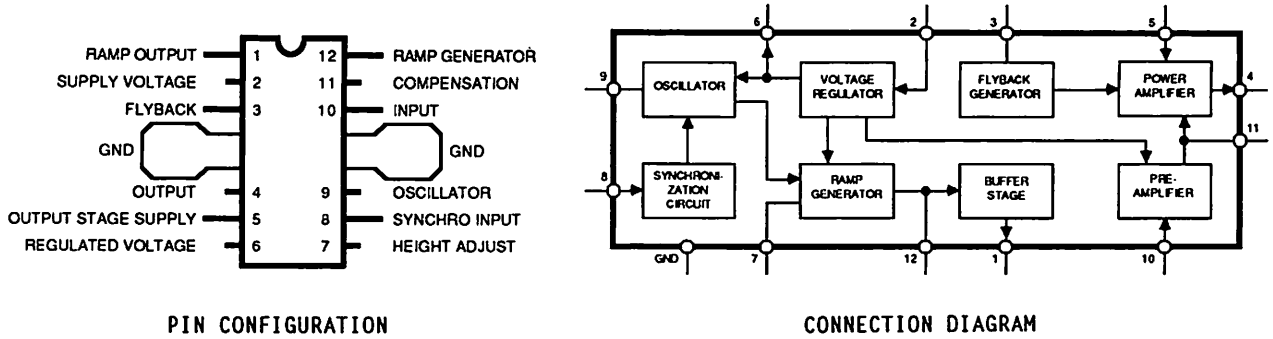
ENABLE		ADDRESS			OUTPUTS								
E3	E2	E1	A2	A1	A0	Y0	Y1	Y2	Y3	Y4	Y5	Y6	Y7
X	X	H	X	X	X	L	L	L	L	L	L	L	L
L	X	X	X	X	X	L	L	L	L	L	L	L	L
X	H	X	X	X	X	L	L	L	L	L	L	L	L
H	L	L	L	L	L	H	L	L	L	L	L	L	L
H	L	L	L	L	H	L	L	L	L	L	L	L	L
H	L	L	L	H	L	L	L	H	L	L	L	L	L
H	L	L	H	L	L	L	L	L	L	H	L	L	L
H	L	L	H	H	L	L	L	L	L	L	H	L	L
H	L	L	H	H	H	L	L	L	L	L	L	H	L
H	L	L	H	H	H	L	L	L	L	L	L	L	H

H = High level, L = low level, X = don't care

FUNCTION TABLE

Figure 6-8 Decoder

TYPE	IC NUMBER	LOCATION	REF. DES.
Circuit, Deflection	TDA1170N	Display (A11)	U101

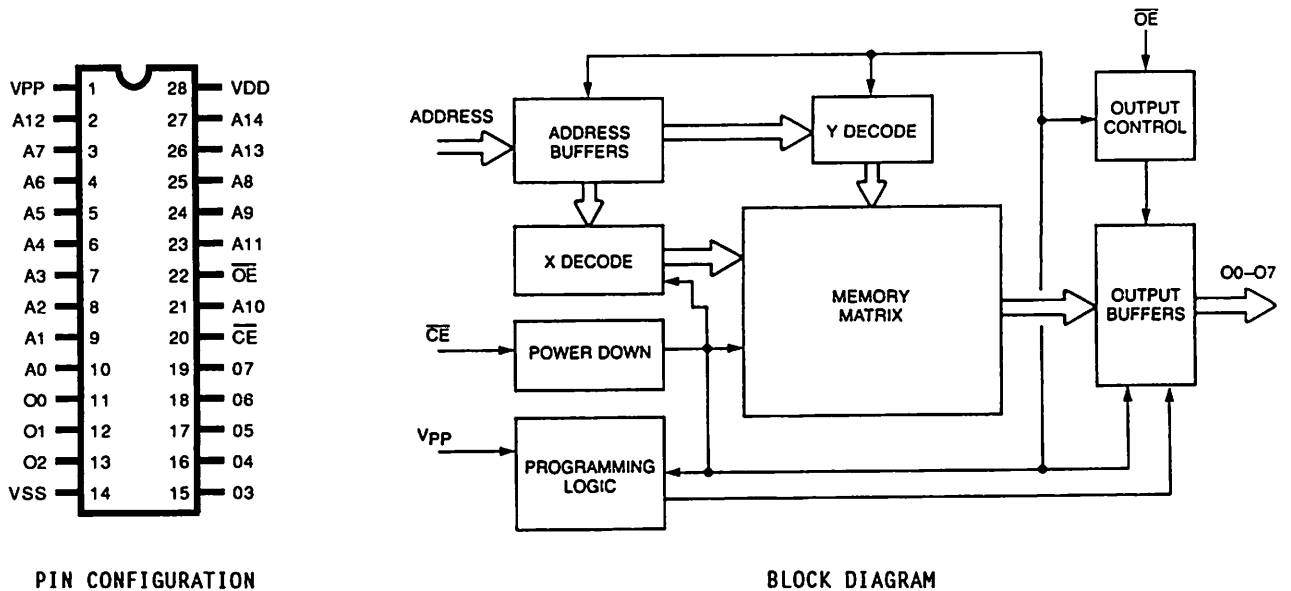


PIN CONFIGURATION

CONNECTION DIAGRAM

Figure 6-9 Deflection Circuit


TYPE	IC NUMBER	LOCATION	REF. DES.
EPROM	27C256	Main (A1)	U22



PIN CONFIGURATION

BLOCK DIAGRAM

Figure 6-10 EPROM

TYPE	IC NUMBER	LOCATION	REF. DES.
Flip-Flop, D-Type 	74HC74	Main (A1)	U16

**FUNCTION TABLE**

PR	Inputs			Outputs	
	CLR	CLK	D	Q	$\bar{Q}$
L	H	X	X	H	L
H	L	X	X	L	H
L	L	X	X	H*	H*
H	H	1	H	H	L
H	H	1	L	L	H
H	H	L	X	Q0	Q0

H = High Level  
 L = Low Level  
 Q0 = Level of Q before steady-state conditions were established  
 X = Irrelevant

\*This configuration is not stable; it will not persist when preset and clear inputs return to their inactive (high) level

**CONNECTION DIAGRAM**

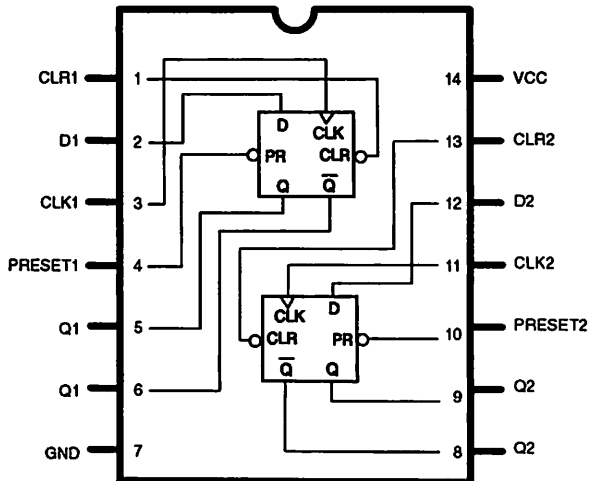



Figure 6-11 D-Type Flip-Flop

TYPE	IC NUMBER	LOCATION	REF. DES.
Flip-Flop, D-Type 	74HCT374	Main (A1)	U19, U20

**FUNCTION TABLE**

Output Control	Clock	Data	Output
L	↑	H	H
L	↑	L	L
L	L	X	Q0
H	X	X	Z

H = High Level  
 L = Low Level  
 Q0 = Level of output before steady-state input conditions were established  
 ↑ = Transition from Low to High  
 X = Irrelevant  
 Z = High Impedance

**CONNECTION DIAGRAM**

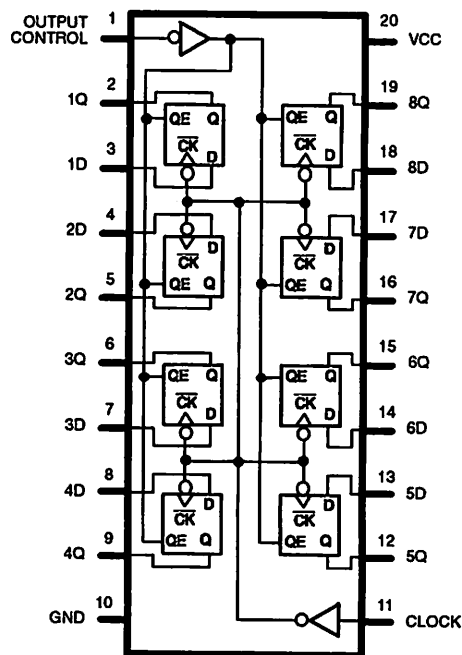

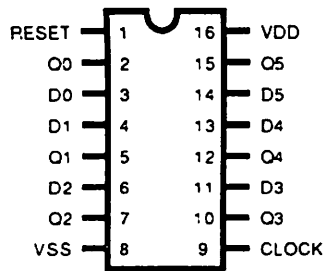
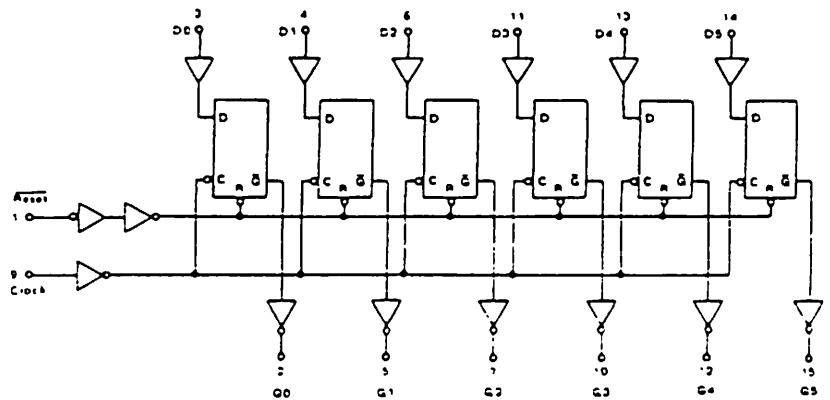


Figure 6-12 D-Type Flip-Flop




TYPE	IC NUMBER	LOCATION	REF. DES.
Flip-Flop, D-Type 	74HC174	Main (A1)	U33



PIN CONFIGURATION



FUNCTIONAL DIAGRAM


INPUTS			OUTPUT
Clock	Data	Reset	Q
	0	1	0
	1	1	1
	x	1	Q
x	x	0	0

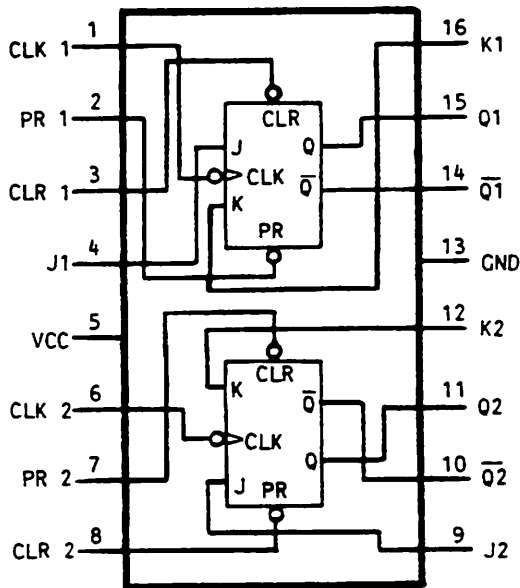
No Change

x = Don't Care

FUNCTION TABLE

Figure 6-13 D-Type Flip-Flop

TYPE	IC NUMBER	LOCATION	REF. DES.
Flip-Flop, J-K 	74HC76	Main (A1)	U36




CONNECTION DIAGRAM

INPUTS					OUTPUTS	
PR	CLR	CLK	J	L	Q	Q̄
L	H	X	X	X	H	L
H	L	X	X	X	L	H
L	L	X	X	X	L*	L*
H	H	↓	L	L	Q0	Q̄0
H	H	↓	H	L	H	L
H	H	↓	L	H	L	H
H	H	↓	H	H	TOGGLE	TOGGLE
H	H	H	X	X	Q0	Q̄0

\*This is an unstable condition, and is not guaranteed

FUNCTION TABLE

Figure 6-14 J-K Flip-Flop


TYPE	IC NUMBER	LOCATION	REF. DES.
Gate Array, Display 		Main (A1)	U29

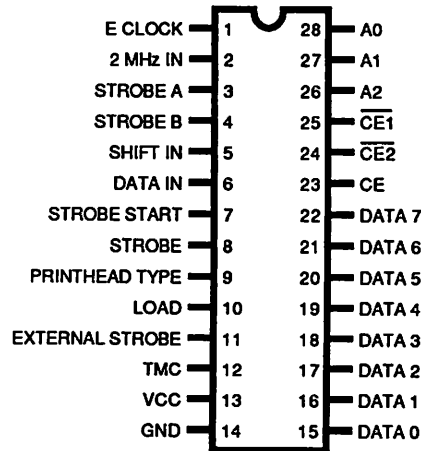
PIN CONFIGURATION

N	NC N-1	NC N-2	NC N-3	VSS N-4	NC N-5	EDAT1 N-6	EDAT3 N-7	EDAT6 N-8	RASTER N-9	VIDEO1 N-10	VSS N-11	NC N-12	NC N-13							
M	NC M-1	NC M-2	NC M-3	NC M-4	SXTR2 M-5	EDAT0 M-6	EDAT4 M-7	EDAT7 M-8	VIDEO2 M-9	FRAME M-10	NC M-11	NC M-12	NC M-13							
L	NC L-1	NC L-2	NC L-3	NC L-4	VDD L-5	EDAT2 L-6	EDAT5 L-7	VRAMCE L-8	NC L-9	NC L-10	NC L-11	NC L-12	NC L-13							
K	NC K-1	VDD K-2	NC K-3	NC K-4	BOTTOM					NC K-10	NC K-11	NC K-12	NC K-13							
J	AD10 J-1	AD11 J-2	NC J-3										CDAT6 J-11	TMC J-12	CDAT7 J-13					
H	AD7 H-1	AD8 H-2	AD9 H-3										CDAT3 H-11	CDAT5 H-12	CDAT4 H-13					
G	VDD G-1	VSS G-2	AD6 G-3										CDAT0 G-11	CDAT1 G-12	CDAT2 G-13					
F	AD4 F-1	AD3 F-2	AD5 F-3										FAD3 F-11	FAD4 F-12	31KHZ F-13					
E	AD1 E-1	AD0 E-2	AD2 E-3										NC E-11	FAD1 E-12	FAD2 E-13					
D	VSS D-1	NC D-2	NC D-3	NC D-4										NC D-10	NC D-11	VDD D-12	FAD0 D-13			
C	NC C-1	NC C-2	NC C-3	NC C-4	NC C-5	TCLK1 C-6	GO C-7	NC C-8	TCLK2 C-9	NC C-10	NC C-11	NC C-12	NC C-13							
B	NC B-1	NC B-2	NC B-3	VDD B-4	RESET B-5	CHAR/TF B-6	VSS B-7	NC B-8	NC B-9	NC B-10	NC B-11	NC B-12	NC B-13							
A	NC A-1	NC A-2	NC A-3	16MHZ A-4	H.RETR A-5	INCMEM A-6	TCLR1 A-7	VDD A-8	TCLK3 A-9	VSS A-10	NC A-11	NC A-12	NC A-13							

Figure 6-15 Display Gate Array

1 2 3 4 5 6 7 8 9 10 11 12 13

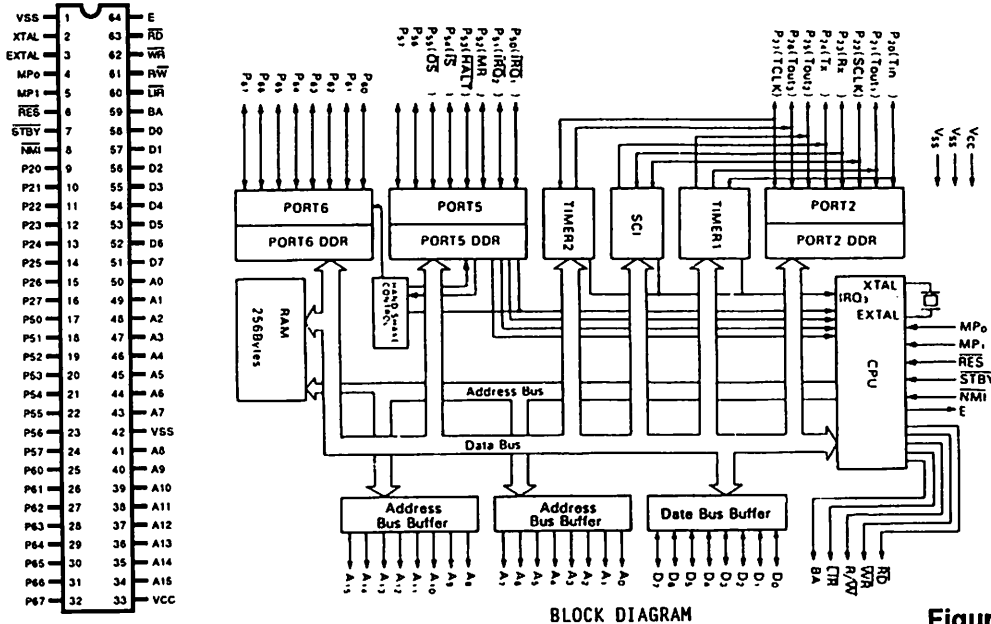
TYPE	IC NUMBER	LOCATION	REF. DES.
Gate Array, Recorder 		Main (A1)	U3



PIN CONFIGURATION

Figure 6-16 Recorder Gate Array

TYPE	IC NUMBER	LOCATION	REF. DES.
Microprocessor 	63B03Y	Main (A1)	U1, U30

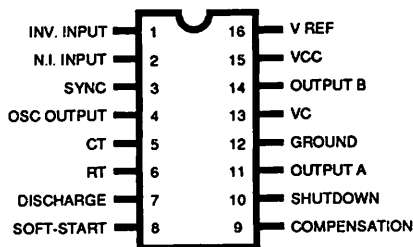


PIN CONFIGURATION

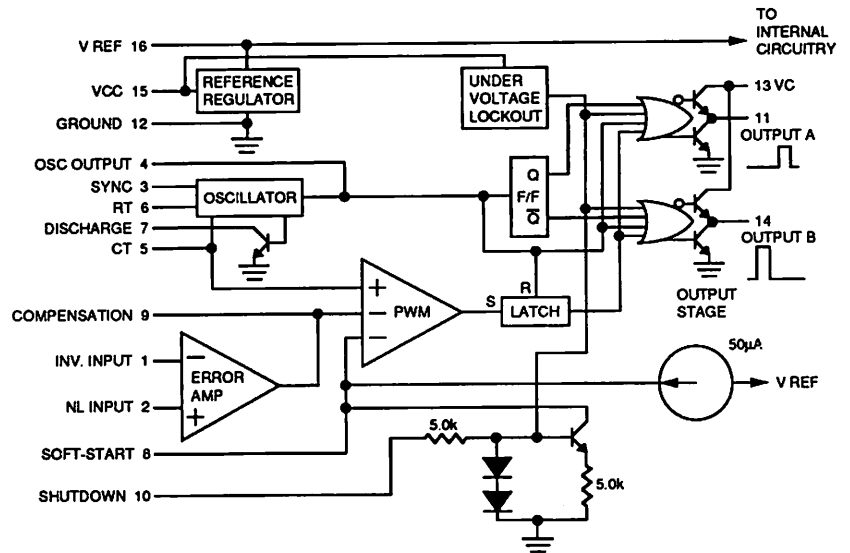
BLOCK DIAGRAM

Figure 6-17 Microprocessor

TYPE	IC NUMBER	LOCATION	REF. DES.
Modulator, Pulse-Width	3525A	Main (A1)	U5




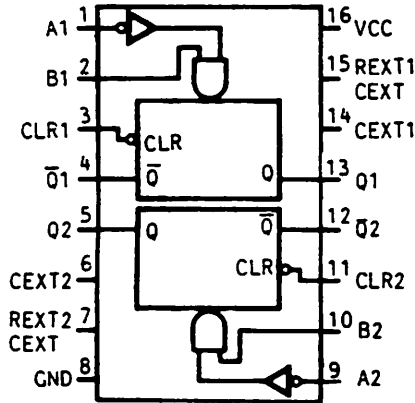
PIN CONFIGURATION



FUNCTIONAL DIAGRAM



Figure 6-18 Pulse-Width Modulator

TYPE	IC NUMBER	LOCATION	REF. DES.
Multivibrator 	74HC221	Main (A1)	U31




CONNECTION DIAGRAM

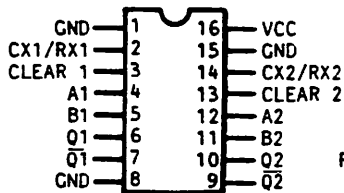
INPUTS			OUTPUTS	
CLEAR	A	B	Q	$\bar{Q}$
L	X	X	L	H
X	H	X	L	H
X	X	L	L	H
H	L	↓	↑	↓
H	↓	H	↑	↓
↑	L	H	↑	↓

H = HIGH LEVEL  
 L = LOW LEVEL  
 ↓ = TRANSITION FROM LOW TO HIGH  
 ↑ = TRANSITION FROM HIGH TO LOW  
 = ONE HIGH LEVEL PULSE  
 = ONE LOW LEVEL PULSE  
 X = IRRELEVANT

FUNCTION TABLE

Figure 6-19 Multivibrator



TYPE	IC NUMBER	LOCATION	REF. DES.
Multivibrator 	4538	Main (A1)	U26

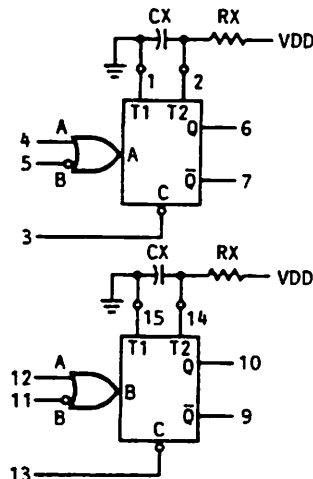


PIN CONFIGURATION

INPUTS			OUTPUTS	
CLR	A	B	Q	$\bar{Q}$
L	X	X	L	H
X	H	X	L	H
X	X	L	L	H
H	L	↓	↑	↓
H	↓	H	↑	↓

FUNCTION TABLE

H=High Level  
 L=Low Level  
 ↓=Transition from Low to High  
 ↑=Transition from High to Low  
 =One High Level Pulse  
 =One Low Level Pulse  
 X=Irrelevant



RX AND CS ARE EXTERNAL COMPONENTS

FUNCTIONAL DIAGRAM

Figure 6-20 Multivibrator



TYPE	IC NUMBER	LOCATION	REF. DES.
Oscillator	NCM031C	Main (A1)	U10

NC	1	14	VDD
NC	2	13	NC
NC	3	12	OUT (1/16)
NC	4	11	OUT (1/8)
NC	5	10	OUT (1/4)
NC	6	9	OUT (1/2)
GND	7	8	OUT (1/1)


OUTPUT FREQUENCY (in MHz)

BASE FREQUENCY	OUTPUT DIVIDING RATIOS				
	1/1	1/2	1/4	1/8	1/16
16.000	16.000	8.000	4.000	2.000	1.000

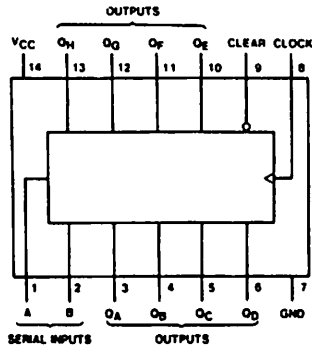
FREQUENCY TABLE

PIN CONFIGURATION

Figure 6-21 Oscillator

TYPE	IC NUMBER	LOCATION	REF. DES.
Register, Shift 	74HC164	Power Conversion (A3)	U19, U20

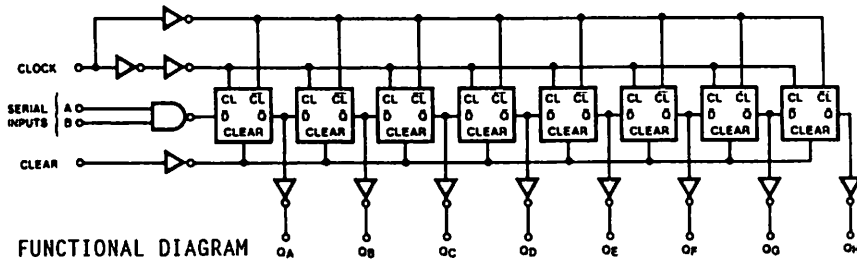
CONNECTION DIAGRAM



Inputs				Outputs			
Clear	Clock	A	B	QA	QB	...	QH
L	X	X	X	L	L	...	L
H	L	X	X	QA0	QB0	...	QH0
H	↑	H	H	H	QAn	...	QGn
H	↑	L	X	L	QAn	...	QGn
H	↑	X	L	L	QAn	...	QGn

H = High Level (steady state), L = Low Level (steady state)  
 X = Irrelevant (any input, including transitions)  
 ↑ = Transition from low to high level.  
 QA0, QB0, QH0 = the level of QA, QB, or QH, respectively, before the indicated steady state input conditions were established.  
 QAn, QGn = The level of QA or QG before the most recent ↑ transition of the clock; indicated a one-bit shift.

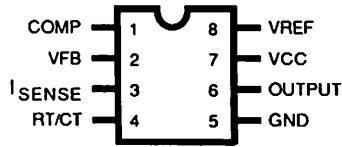
FUNCTION TABLE



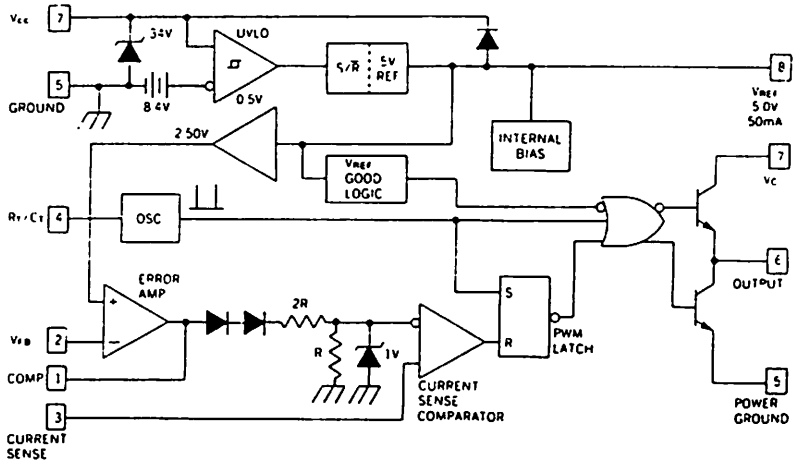
FUNCTIONAL DIAGRAM

Figure 6-22 Shift Register

TYPE	IC NUMBER	LOCATION	REF. DES.
Regulator, Pulse-Width	2843N	Power Conversion (A3)	U3



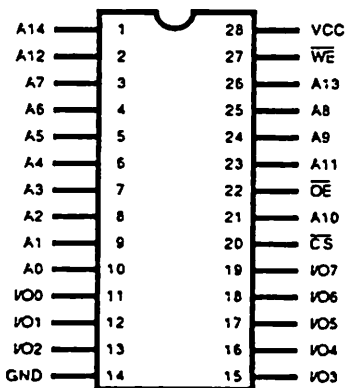
PIN CONFIGURATION



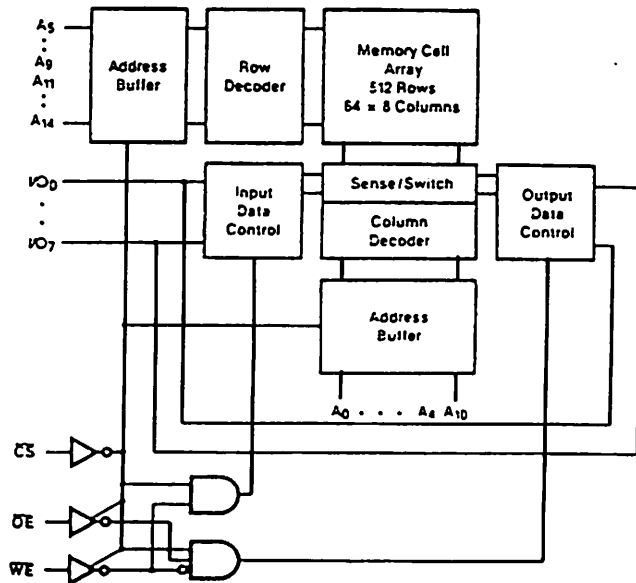
FUNCTIONAL DIAGRAM

Figure 6-23 Pulse-Width Regulator

TYPE	IC NUMBER	LOCATION	REF. DES.
Static RAM, 32k x 8	HM62256LP-12	Main (A1)	U13, U21




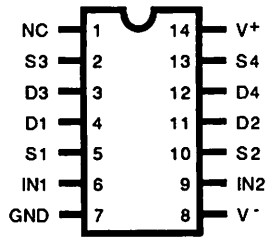
PIN CONFIGURATION



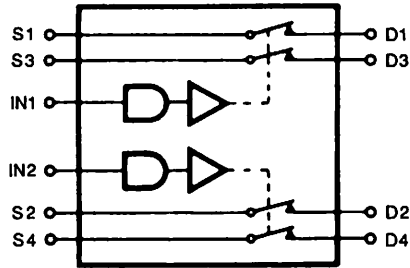
BLOCK DIAGRAM

Figure 6-24 Static RAM, 32k x 8

TYPE	IC NUMBER	LOCATION	REF. DES.
Switch, Analog 	DG307, DG302	Main (A1)	U40, U43



PIN CONFIGURATION




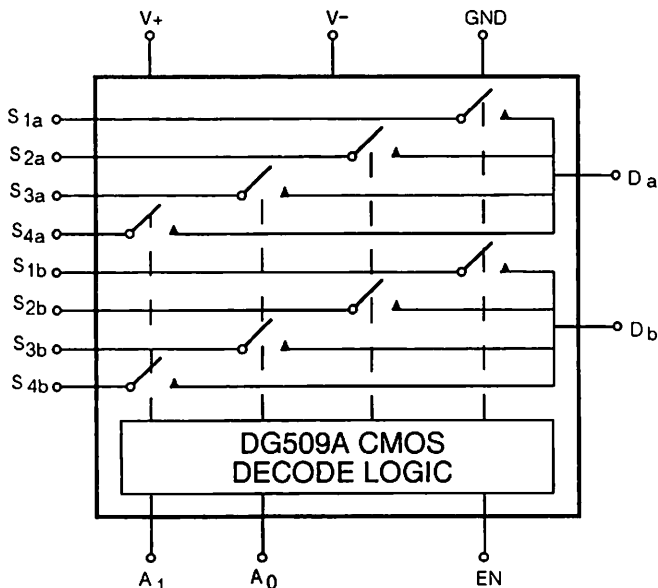
FUNCTIONAL DIAGRAM

LOGIC	SWITCH
0	OFF
1	ON

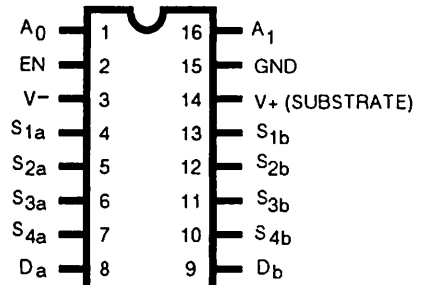
FUNCTION TABLE

Figure 6-25 Analog Switch

TYPE	IC NUMBER	LOCATION	REF. DES.
Switch, Analog 	DG509	Main (A1)	U41, U42



FUNCTIONAL DIAGRAM



PIN CONFIGURATION

Figure 6-26 Analog Switch



# Index

## Numbers

1mV CAL Pushbutton, 2-6

## A

AC Mains Power Switch (Rear Panel), 2-6  
Accessories and Supplies, 5-5  
Adapters and Accessories, 5-5  
Address Decode Circuit, 1-26  
Analog Voltage Evaluation Circuit, 1-15  
APEX Paddle Description, 2-5  
Assembly (Theory of Operation)  
  Display PCB/CRT, 1-32  
  Interconnect PCB, 1-16  
  Main PCB, 1-17  
  Power Conversion PCB, 1-9  
  Power Supply PCB, 1-8  
Audio Alarms Circuit, 1-24

## B

BATT CHRГ Check (PIP), 3-5  
BATT CHRГ Indicator, 2-4  
BATT CHRГ Indicator Circuit, 1-9  
Battery  
  Battery Pack Removal, 4-7  
  Low Battery Threshold Checks (TCP), 3-23  
  Maintenance, 4-1  
    Battery Capacity Check, 4-2  
    Guidelines, 4-2  
    Replacement Batteries, 4-2  
  Recharging, 4-1  
  Recycling, 4-4  
  Theory of Operation, 1-8  
Battery Power Check (PIP), 3-5

## C

Cable Accessories, 5-5  
Calibration. *See* Test and Calibration Procedure (TCP)  
Capacitor Charge Control Circuit, 1-13  
Capacity, Battery Check, 4-2  
Charge Control Circuit, 1-25  
Charge LED Drive Circuit, 1-16  
Charge LED Indicator, 2-5  
CHARGE Pushbutton, 2-3, 2-5  
Charging Batteries, 4-1  
Checklist  
  PIP, 3-18  
  TCP, 3-39  
Circuit Descriptions. *See* Theory of Operation  
Cleaning  
  Procedures, 4-13  
    External, 4-13  
    Interior, 4-14  
  Tools and Materials for, 4-13  
Clock Setting Procedure, 2-10  
CODE SUMMARY  
  PIP-CODE SUMMARY, 3-14  
  Pushbutton Description, 2-3  
Configuration Information, xvii  
Controls and Indicators, 2-1  
  Front Panel, 2-3  
  Rear Panel, 2-6  
CRT Bias Generator Circuit, 1-35  
CRT Connector Assy (Part of Display PCB/CRT Assy), 5-67  
CRT Disassembly, 4-10  
CRT Display, 2-4  
CRT Frequency Response Test (TCP), 3-38

## D

DC Restore Circuit, 1-21  
Defibrillation Adapter  
  Final Assembly, 5-87  
  List of Assemblies, 5-4

- Parts List, 5-85
- Schematic, 5-86
- Defibrillator Calibration, 3-25**
  - Table of Measurement Ranges (TCP), 3-26
- Description**
  - Functional, 1-6
  - Physical, 1-1
- Disassembly Procedures, 4-6**
  - Battery Pack Removal, 4-7
  - Case Separation, 4-8
  - Display PCB/CRT Removal, 4-10
  - Front Panel Bezel Removal, 4-7
  - Interconnect PCB Removal, 4-11
  - Keypad Assembly Removal, 4-7
  - Main PCB Removal, 4-10
  - Power Conversion PCB Removal, 4-10
  - Power Supply Removal, 4-11
  - Strip Chart Recorder Removal, 4-8
- Discharge Pushbuttons, 2-5**
- Display Calibration, 3-29**
- Display Gate Array Circuit, 1-26**
- Display PCB/CRT Assembly**
  - Disassembly, 4-10
  - Monitor PCB (part of Display PCB/CRT), Parts List, 5-60
  - Parts List, 5-58
  - Theory of Operation, 1-32
- Display/Recorder Controller Circuit, 1-25**

## E

- ECG Electrodes, Accessories, 5-5**
- ECG Gain Indication, 2-4**
- ECG Output**
  - ECG Output (TCP Test), 3-38
  - ECG OUTPUT Rear Panel Connection, 2-6
  - ECG Output Specifications, 1-3
- ECG SIZE Pushbutton, 2-3**
- Echo Circuit, 1-22**
- Effective Publication Dates, xvi**
- Energy Dump Circuit, 1-14**
- Energy Monitor Circuit, 1-15**
- ENERGY SELECT Pushbutton, 2-3**
- Energy Selection Display, 2-4**
- Energy Storage Capacitor Charger Circuit, 1-11**
- Energy Transfer Circuit, 1-13**
- EPROM**
  - Font, 1-29
  - Program, 1-29

- Error Codes, 3-40**
- External Control Input Circuit, 1-11**

## F

- FAST-PATCH Electrodes, Ordering, 5-5**
- Fault Status Codes (Error Codes), 3-40**
- Filtering Circuit, 1-21**
- Final Assembly**
  - Defibrillation Adapter, 5-87
  - Defibrillator/Monitor
    - Drawing, 5-13
    - Parts List, 5-6
- Font EPROM Circuit, 1-29**
- Frame Sweep Generator Circuit, 1-34**
- Front and Rear Panel Controls Interface Circuit, 1-24**
- Front Panel, Controls and Indicators Description, 2-3**
- Front-End Protection Circuit, 1-19**
- Functional Block Diagram, 1-7**
- Functional Description, 1-6**
- Functional Test and Calibration. See Test and Calibration Procedure (TCP)**
- Fuse Replacement, 4-5**
  - Fuse Cover (Rear Panel), 2-6

## G

- Ground Connection (Rear Panel), 2-6**

## H

- Heart Rate Alarm Limits, 2-4**
- Heart Rate Display, 2-4**
- HR ALARM Pushbutton, 2-3**

## I

- I/O Protection Circuit, 1-25**
- Info Menu, 2-9**
- Inspection Techniques, 4-11**
  - Exterior Inspection, 4-11
  - Interior Inspection, 4-11
- Instruction Decoding Circuit, 1-20**
- Instrumentation Amplifier Circuit, 1-20**
- Interconnect Diagram, 5-14**
- Interconnect PCB Assembly**
  - Disassembly, 4-11
  - Parts List, 5-45

PCB Layout, 5-47  
 Schematic, 5-48  
 Theory of Operation, 1-16  
**Isolated Power Supply Circuit, 1-19**

## J

**JOULES SELECTED Indicator, 2-4**

## K

**Keypad Assembly, 5-50**  
 Parts List, 5-50  
 PCB Layout, 5-50  
 Schematic, 5-50

## L

**Lead Select Circuit, 1-19**  
**Lead Select Indicator, 2-4**  
**LEAD SELECT Pushbutton, 2-3**  
**Leakage Current Check (PIP), 3-16**  
**List of Defibrillation Adapter Assemblies, 5-4**  
**List of Major Assemblies, 5-3**  
**Logic Power Monitor Circuit, 1-10**  
**Low Battery Threshold Checks (TCP), 3-23**  
**Low Energy Charge Rate Circuit, 1-12**

## M

### Main PCB

Block Diagram, 1-18  
 Disassembly, 4-10  
 Display/Recorder Interface, 1-25  
   Address Decode, 1-26  
   Display Gate Array, 1-26  
   Display/Recorder Controller, 1-25  
   Font EPROM, 1-29  
   Motor Speed Control, 1-30  
   Printhead Control, 1-30  
   Printhead Resistance Evaluation, 1-32  
   Program EPROM, 1-29  
   Program RAM, 1-29  
   Recorder Power, 1-30  
   System Clock, 1-26  
   Video RAM, 1-29  
 Parts List, 5-15  
 PCB Layout, 5-24  
 Preamp, 1-19

DC Restore, 1-21  
 Echo, 1-22  
 Filtering, 1-21  
 Front-End Protection, 1-19  
 Instruction Decoding, 1-20  
 Instrumentation Amplifier, 1-20  
 Isolated Power Supply, 1-19  
 Lead Select, 1-19  
 Optical Interface, 1-19  
 Schematic, 5-25  
 System Controller, 1-24  
   Audio Alarms, 1-24  
   Charge Control, 1-25  
   Front and Rear Panel Controls Interface, 1-24  
   I/O Protection, 1-25  
 Theory of Operation, 1-17

### Mains Power Switch (Rear Panel), 2-6

### Maintenance

Battery, 4-1  
 General  
   Fuse Replacement, 4-5  
   Strip Chart Recorder, 4-4  
     Cleaning, 4-5  
     Loading Paper, 4-4  
     Protecting Printouts, 4-5

### Major Assemblies, 5-3

### Message Display, 2-4

### MODE Pushbutton. See Setting the Clock

### Monitor PCB (Part of Display PCB/CRT Assy)

Parts List, 5-60  
 PCB Layout, 5-65  
 Schematic, 5-66

### Motor Speed Control Circuit, 1-30

## O

### ON Pushbutton, 2-3

### Optical Interface Circuit, 1-19

### Option Settings, 2-7

Info Menu, 2-9  
 Setup Menu, 2-8  
 Test Menu, 2-7

### Ordering Replacement Parts, 5-2

### Output Isolation Circuit, 1-8

### Overvoltage Protection Circuit, 1-8

## P

### Packing and Storage or Shipping, 4-16

### Paddle Assembly, 5-56

Parts List, 5-56  
 Schematic, 5-56

- Parts Lists, Explanation of, 5-1**
- Parts, How to Order, 5-2**
- PARTSLINE Telephone Number, 5-2**
- Patient Cable Connector, 2-5**
- PCB Repair, Precautions, 4-15**
- Performance Inspection Procedure (PIP). See PIP**
- Physical Description, 1-1**
- PIP (Performance Inspection Procedure), 3-1**
  - 1mV CAL, 3-9
  - AC Power, 3-4
  - Battery Charge (BATT CHRG) Check, 3-5
  - Battery Power, 3-5
  - Charge Reduction, 3-13
  - Charge Time, 3-12
  - Checklist, 3-18
  - CODE SUMMARY, 3-14
  - CRT Gain/Aspect Ratio, 3-9
  - Defib Disarm and CHARGE LEDs Check, 3-12
  - Definitions, 3-2
  - Delivered Energy, 3-14
  - Discharge Control, 3-13
  - ECG Display, 3-8
  - Energy Dump, 3-13
  - General Instructions, 3-4
  - Heart Rate, 3-9
  - Keypad Test, 3-7
  - Lead Select, 3-8
  - Leakage Current, 3-16
  - Paddle Polarity, 3-12
  - Personnel Training Requirements, 3-3
  - Physical Inspection, 3-4
  - Purpose, 3-1
  - Rate Alarms/Alarm-Activated Record, 3-10
  - Recorder Annotation/Real-Time Clock, 3-10
  - Recorder Speed/Baseline Centering, 3-8
  - Recorder/CRT Noise, 3-11
  - Required Test Equipment, 3-2
  - Requirements, 3-2
  - Scope and Applicability, 3-2
  - Setup Menu Settings, 3-5
  - Sync/Sync Annotation, 3-11
  - Test Equipment Required, 3-2
  - Test Load, 3-10
  - Test Setup, 3-5
  - Workstation Requirements, 3-3
- Power Control Circuit, 1-9**
- Power Conversion PCB Assembly, 1-9**
  - Disassembly, 4-10
  - Parts List, 5-34
  - PCB Layout, 5-41

- Schematic, 5-42
- Theory of Operation, 1-9
- Voltage Checks (TCP Test), 3-23
- Power Supply PCB Assembly, 1-8**
  - Calibration (TCP), 3-33
  - Disassembly, 4-11
  - Parts List, 5-29
  - PCB Layout, 5-32
  - Schematic, 5-33
  - Theory of Operation, 1-8
- Power-On Circuit, 1-8**
- Preamp, Pulse Widths, 1-21**
- Preamp Circuit, 1-19**
- Printer. See Strip Chart Recorder**
- Printhead Control Circuit, 1-30**
- Printhead Resistance Evaluation Circuit, 1-32**
- Program EPROM Circuit, 1-29**
- Program RAM Circuit, 1-29**
- Publication Dates, Effective, xvi**

## Q

- QRS Indicator, 2-4**
- QRS VOL Pushbutton, 2-6**

## R

- Raster Generator Circuit, 1-35**
- Raster Scan Oscillator Circuit, 1-34**
- Raster Voltage Generator Circuit, 1-34**
- Rear Panel Membrane Switch, 5-51**
  - PCB Layout, 5-51
  - Schematic, 5-51
- Recharging Batteries, 4-1**
- RECORD Pushbutton, 2-3**
- Recorder**
  - See also* Strip Chart Recorder
  - Brief description, 2-5
  - Recorder Calibration, 3-34
  - Recorder Frequency Response test (TCP), 3-36
- Recorder Power Circuit, 1-30**
- Recycling Batteries, 4-4**
- Reference Designator Key, 5-4**
- Regulation Circuit, 1-8**
- Removal and Replacement of Assemblies. See Disassembly Procedures**
- Repair and Cleaning, Tools and Materials for, 4-13**
- Replacement Parts, How to Order, 5-2**



## S

### Safety

- General Information, xii
- Symbols, xiv
- Terms, xii

### Schematic Diagram

- Defibrillation Adapter, 5-86
- Display PCB/CRT (Monitor PCB), 5-66
- Explanation of, 5-2
- Interconnect PCB, 5-48
- Keypad Assembly, 5-50
- Main PCB, 5-25
- Paddle Assembly, 5-56
- Power Conversion PCB, 5-42
- Power Supply PCB, 5-33
- Rear Panel Membrane Switch, 5-51
- Sense Leads PCB (Mounted on Power Conversion PCB), 5-42
- Strip Chart Recorder, 5-54
- Transfer Relay Assembly, 5-55

### Sense Leads PCB (on Power Conversion PCB)

- PCB Layout, 5-41
- Schematic, 5-42

### Serial Data Interface Circuit, 1-15

### Service and Maintenance Information, 4-1

### SERVICE Indicator and Error Codes

- Error Codes, 3-40
- How to Clear, 3-40
- Status Message Display, 2-4

### Service Information Overview, xv

### SET Pushbutton. See Setting the Clock

### Setting the Clock, 2-10

### Setup Menu

- Access, 2-8
- Settings for PIP, 3-5

### Specifications, 1-3

### SSD (Static Sensitive Devices)

- Proper Storage, 4-6
- Special Handling of, 4-5
- Static-Dissipative Mat, 4-6
- Static-Free Work Area, 4-6
- Symbol, 4-5
- Work Area, 4-6
- Wrist Strap, 4-6

### Static Sensitive Devices. See SSD

### Status Message Display, 2-4

### STERNUM Paddle Description, 2-5

### Storage or Shipping, 4-16

### Strip Chart Recorder

- Assembly Drawing, 5-53
- Cleaning, 4-5
- Disassembly Procedure, 4-8
- Loading Paper, 4-4
- Maintenance, 4-4
- Parts List, 5-52
- Protecting Printouts, 4-5
- Recorder Calibration (TCP), 3-34
- Recorder Frequency Response Test (TCP), 3-36
- Schematic, 5-54

### Supplies and Accessories, 5-5

### Switching Power Supply Circuit, 1-11

### Symbols

- Explanation of, xiv
- Used in Manual or on Equipment, xiv

### SYNC Pushbutton, 2-3

### System Clock Circuit, 1-26

### System Controller Circuit, 1-24

## T

### TCP. See Test and Calibration Procedure

### Terms, Definition of, xii

### Test and Calibration Procedure (TCP), 3-20

- Charge Time, 3-28
- Checklist, 3-39
- CRT Frequency Response, 3-38
- Defibrillator Calibration, 3-25
- Defibrillator Charge Time, 3-28
- Definitions, 3-20
- Display Calibration, 3-29
- ECG Output, 3-38
- Low Battery Threshold Checks, 3-23
- Output Waveform, 3-28
- Personnel Training Requirements, 3-21
- Power Supply Calibration, 3-33
- Purpose, 3-20
- Recorder Calibration, 3-34
- Recorder Frequency Response, 3-36
- Requirements, 3-20
- Scope, 3-20
- Test Equipment Required, 3-21
- Test Load Calibration, 3-27
- Test Menu Access, 3-25
- Voltage Checks, 3-22
- Workstation Requirements, 3-21

### Test Equipment Required

- PIP, 3-2
- Test and Calibration, 3-21

### Test Load, 2-5

### Test Load Calibration (TCP), 3-27

**Test Menu**

- Access, 2-7
- TCP-Test Menu Access, 3-25

**Testing**

- PIP (Performance Inspection Procedure), 3-1
- TCP (Test and Calibration Procedure), 3-20

**Theory of Operation, 1-8**

- Display PCB/CRT Assembly, 1-32
  - CRT Bias Generator, 1-35
  - Frame Sweep Generator, 1-34
  - Raster Generator, 1-35
  - Raster Scan Oscillator, 1-34
  - Raster Voltage Generator, 1-34
  - Video Signal Amplifier, 1-34
- Interconnect PCB, 1-16
- Main PCB, 1-17
  - Display/Recorder Interface, 1-25
    - Address Decode, 1-26
    - Display Gate Array, 1-26
    - Display/Recorder Controller, 1-25
    - Font EPROM, 1-29
    - Motor Speed Control, 1-30
    - Printhead Control, 1-30
    - Printhead Resistance Evaluation, 1-32
    - Program EPROM, 1-29
    - Program RAM, 1-29
    - Recorder Power, 1-30
    - System Clock, 1-26
    - Video RAM, 1-29
- Preamp, 1-19
  - DC Restore, 1-21
  - Echo, 1-22
  - Filtering, 1-21
  - Front-End Protection, 1-19
  - Instruction Decoding, 1-20
  - Instrumentation Amplifier, 1-20
  - Isolated Power Supply, 1-19
  - Lead Select, 1-19
  - Optical Interface, 1-19
- System Controller, 1-24
  - Audio Alarms, 1-24
  - Charge Control, 1-25

- Front and Rear Panel Controls Interface, 1-24
- I/O Protection, 1-25
- Power Conversion PCB, 1-9
  - Analog Voltage Evaluation, 1-15
  - Capacitor Charge Control, 1-13
  - Charge LED Drive, 1-16
  - Energy Dump, 1-14
  - Energy Monitor, 1-15
  - Energy Storage Capacitor Charger, 1-11
  - Energy Transfer, 1-13
  - External Control Input, 1-11
  - Logic Power Monitor, 1-10
  - Low Energy Charge Rate, 1-12
  - Power Control, 1-9
  - Serial Data Interface, 1-15
  - Switching Power Supply, 1-11
- Power Supply PCB, 1-8
  - BATT CHRG Indicator, 1-9
  - Battery, 1-8
  - Output Isolation, 1-8
  - Overvoltage Protection, 1-8
  - Power-On, 1-8
  - Regulation, 1-8

- TIME/DAY Pushbutton. See Setting the Clock**
- Tools and Materials for Cleaning, 4-13**
- Tools and Materials for Repair, 4-13**
- Transfer Relay Assembly, 5-55**
  - Schematic, 5-55
- Troubleshooting Aids, 3-40**

**V**

- Video RAM Circuit, 1-29**
- Video Signal Amplifier Circuit, 1-34**

**W**

- Warnings, xiii**
  - General, xiii

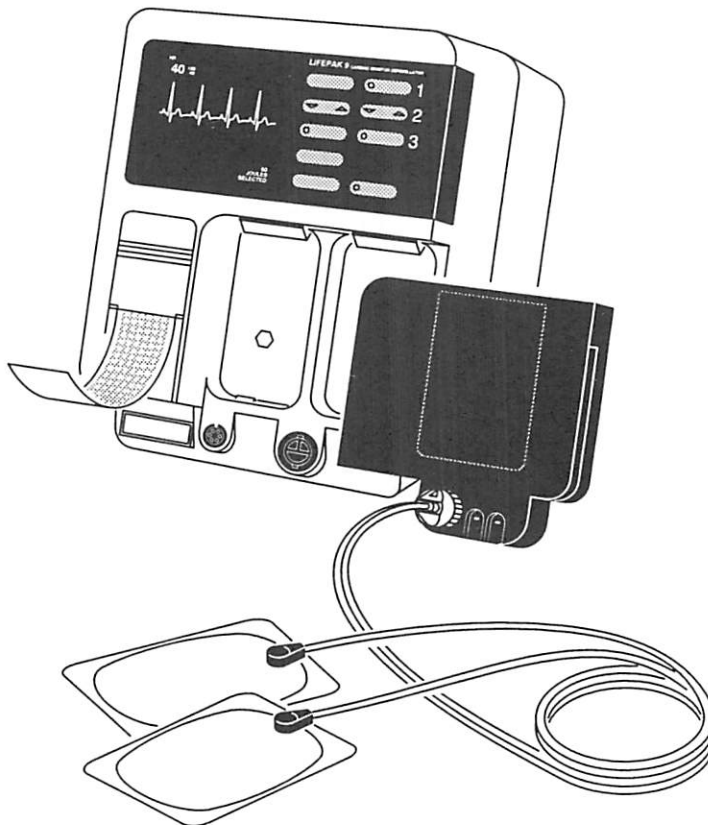
# Service Manual Addendum

LIFEPAK 9® defibrillator/monitor with the Shock Advisory Adapter or Defibrillation Adapter

## Introduction

This addendum describes a new configuration of the LIFEPAK 9 defibrillator/monitor that does not have standard paddles (see Figure 1). Instead, it uses the Shock Advisory Adapter or Defibrillation Adapter when defibrillating or monitoring.

This configuration is available for the LIFEPAK 9, 9P, 9B, and 9A defibrillator/monitors.



**Figure 1** LIFEPAK 9 defibrillator/monitor and adapter

Contact your local Physio-Control sales or service office for technical consultation or parts (PARTSLINE™). In the USA, call Technical Services at 1-800-442-1142.

## Changes to Tests

Because the tests in the LIFEPAK 9 (and 9P, 9B, and 9A) defibrillator/monitor Service Manual are written using the standard paddles, some tests must be changed so they can be performed using the Shock Advisory Adapter or Defibrillation Adapter. The following paragraphs describe these changes to tests in the Performance Inspection Procedure (PIP) and Test and Calibration Procedure (TCP).

The tests in this Addendum do not include all of the tests in the PIP and TCP of your service manual. For the complete PIP and TCP for this new configuration, perform both the tests in this Addendum and those in the Service Manual. Many of the following tests are complete replacements for the tests in the Service Manual; however, there are two in the PIP that require only a brief explanation of the necessary modifications to the existing tests.

## Performance Inspection Procedure (PIP)

The tests listed below *replace* or *modify* the tests in the Service Manual:

**Table 1 PIP Tests in this Addendum**

<b>Addendum Tests</b>	<b>Respective Service Manual Test</b>
AC Power	Modifies
Keypad Test	Modifies
Test Load	Replaces
Sync/Sync Annotation	Replaces
Recorder/CRT Noise	Replaces
Defib Disarm and CHARGE LEDs Check	Replaces
Paddle Polarity	Replaces
Charge Time	Replaces
Discharge Control	Replaces
Energy Dump	Replaces
Charge Reduction	Replaces
Delivered Energy	Replaces
CODE SUMMARY Report	Replaces

The following in Table 2 are additions to the PIP Test Equipment listed in the Service Manual:

**Table 2 Additional PIP Test Equipment**

<b>Equipment</b>	<b>Specifications</b>	<b>Manufacturer</b>
LIFEPAK 9 defibrillator/monitor shock advisory adapter or defibrillation adapter	Calibrated	Physio-Control PN 803732 or 803747
Test Paddles	two	Physio-Control PN 803602

 **WARNING**

**Shock hazard.** When charged and discharged during this PIP, the defibrillator discharges up to 360J of electrical energy through the defibrillator electrodes. Unless discharged safely as described in this PIP, this electrical energy may cause injury or death. Do not attempt to perform this procedure unless you are thoroughly familiar with the operation of the defibrillator.

PIP-AC Power

*Replace* step 1 in the Service Manual with the following:

1. Install the Shock Advisory Adapter or Defibrillation Adapter into the defibrillator paddle wells. Connect the instrument to ac power.

PIP--Keypad Test

*Replace* steps 3 through 6 in the Service Manual with the following:

3. Press the CHARGE pushbutton on the adapter, if using the Shock Advisory Adapter.
4. Press the left adapter discharge pushbutton; confirm no beep sounds.
5. Press the right adapter discharge pushbutton; confirm no beep sounds.
6. Simultaneously press both adapter discharge pushbuttons; confirm that a beep sounds.

PIP-Test Load

1. Install the defibrillation cable to the adapter. Attach the ends of the defibrillator cable to the adapter test load connectors.
2. Press ▼ ENERGY SELECT ▲ as necessary to set the energy level to 200J.
3. Press CHARGE on the defibrillator or the adapter.
4. After the defibrillator reaches full charge, simultaneously press both adapter discharge pushbuttons to transfer the energy into the adapter test load. Confirm that **TEST 200 JOULES DELIVERED** displays on the monitor and annotates on the recorder printout.

PIP-Sync/Sync  
Annotation

1. Attach the patient cable to the ECG simulator.
2. Select LEAD II on the defibrillator.
3. Press SYNC. Confirm that **SYNC MODE** displays on the CRT, the sync marker (the inverted triangle) is clearly visible on each displayed R wave, and the SYNC pushbutton LED flashes.
4. With the defibrillation cable attached to the adapter test load connectors, press ▼ ENERGY SELECT ▲ if necessary to set the energy level to 200J.
5. Press CHARGE. After the defibrillator reaches full charge, simultaneously press and hold both adapter discharge pushbuttons until the energy is discharged into the test load.

6. Confirm that the recorder prints the message **SYNC TEST 200 JOULES DELIVERED** and the sync markers are clearly visible on each R wave on the printed ECG trace.
7. Confirm that the **SYNC MODE** display and SYNC pushbutton LED are off, and no sync markers are visible.
8. Disconnect the patient cable from the ECG simulator and disconnect the defibrillation cable from the adapter test load connectors.

PIP-Recorder/CRT  
Noise

1. Connect the test paddles to the ends of the defibrillation cable.
2. Short together the RA and LL leads of the patient cable.
3. Set the ECG gain to X4.0. Select **LEAD II**.
4. Press RECORD to start the recorder.
5. Confirm that the CRT and recorder baseline noise is less than 3mm p-p.
6. Select **PADDLES** electrodes. Short the paddle plates together, wait at least 10 seconds, and then confirm that the CRT and the recorder baseline noise is less than 3mm p-p.

**Note:** *The ECG signal that is displayed on the CRT is delayed approximately 10 seconds before being printed by the recorder.*

7. Press RECORD to turn off the recorder.

PIP-Defib Disarm and  
CHARGE LEDs Check

1. Remove the test paddles from the defibrillation cable and connect the ends of the cable to the adapter test load connectors.
2. Press ▼ ENERGY SELECT ▲ and set the energy level to 0J.
3. Press the CHARGE pushbutton.
4. Confirm that the CHARGE LED does not light and that the CRT continues to display **0 JOULES SELECTED**.
5. Press ▼ ENERGY SELECT ▲ to set the selected energy to 200J.
6. Press CHARGE and confirm that the front panel LED flashes during the charge cycle. If using the Shock Advisory Adapter, the charge LED on the adapter should also flash.
7. Confirm that the LEDs remain on and a tone sounds when full charge is reached.
8. Simultaneously press both paddle discharge pushbuttons to transfer the charge. Confirm that the CHARGE LEDs are off and the recorder prints the message **TEST 200 JOULES DELIVERED**.

PIP-Paddle Polarity

1. Press LEAD SELECT to select **PADDLES** lead.
2. Attach the ends of the defibrillation cable to the ECG simulator (APEX on LL, STERNUM on RA) and confirm that a positive-going QRS complex is visible on the CRT.
3. Disconnect the defibrillation cable from the ECG simulator.

PIP-Charge Time

1. Attach the ends of the defibrillation cable to the adapter test load connectors. Press ▼ ENERGY SELECT ▲ to set the energy level to 360J.
2. Simultaneously press CHARGE and start the timer. Stop the timer when the defibrillator reaches full charge (as indicated by the tone and the displayed message **360 JOULES AVAILABLE**). Confirm that the charge time is less than 10 seconds.
3. Press the adapter discharge pushbuttons simultaneously to transfer the energy into the test load. Confirm that **TEST USE 200 JOULES** displays on the CRT and three tones sound.

PIP-Discharge Control

1. This test is deleted; it should only be performed using standard hard paddles.

PIP-Energy Dump

1. Attach the test paddles to the defibrillation cable and secure the paddles to the energy meter.
2. Press ▲ ENERGY SELECT ▼ and set the energy level to 360J.
3. Press CHARGE.
4. After the instrument charges to 360J, change the energy level to 300J.
5. Confirm **CHARGE REMOVED** is displayed and tones sound.

PIP-Charge Reduction

1. Leave the defibrillation cables attached to the energy meter. Press ▲ ENERGY SELECT ▼ and set the energy level to 360J.
2. Press CHARGE.
3. When full charge is reached, start the timer and immediately change the energy level to 1J and press CHARGE (to perform this test properly, you should scroll to 1J and press CHARGE within a few seconds).
4. Confirm that full charge of 1J is reached within 20 seconds or less after you start the timer. Simultaneously press both discharge pushbuttons and confirm that the energy is discharged into the energy meter.

PIP-Delivered Energy

With the defibrillation cables attached to the energy meter electrodes, refer to Table 3 and confirm that the delivered energy is within tolerances for each energy level.

**Table 3 Delivered Energy Tolerances**

<b>Energy Setting</b>	<b>Tolerance</b>	<b>Energy Setting</b>	<b>Tolerance</b>
1J	±0.2J	10J	±1.0J
2J	±0.2J	20J	±2.0J
3J	±0.3J	30J	±2.1J
4J	±0.4J	50J	±3.5J
5J	±0.5J	100J	±7.0J
6J	±0.6J	200J	±14.0J
7J	±0.7J	300J	±21.0J
8J	±0.8J	360J	±25.2J
9J	±0.9J		

PIP-CODE SUMMARY  
Report

1. Press ON twice to switch instrument power off then on.

**Note:** *If the instrument has the automatic CODE SUMMARY printing feature (805460-20), it will print out all the CODE SUMMARY events in memory before it allows you to switch the power off.*

2. Secure the defibrillation cable to the energy meter electrodes.
3. Connect the ECG simulator to the patient cable and set for a 60 bpm-NSR signal.
4. Press SYNC.
5. If necessary, press ▲ ENERGY SELECT ▼ to set the energy level to 200J.
6. Press CHARGE. When full charge is reached (as indicated by the tone and displayed message **200J AVAILABLE**), simultaneously press both adapter discharge pushbuttons to transfer the energy into the energy meter.
7. Press RECORD twice to switch the recorder on, then off quickly.
8. Press CODE SUMMARY.
9. Confirm that the format and appearance of the recorded data is similar to the data shown below in Figure 2.



NAME	COMMENTS
CODE SUMMARY™	
CRITICAL EVENT RECORD	
19 NOV 91	
POWER ON 14:27:35	
TOTAL SHOCKS 1	
ELAPSED TIME 01:12:49	

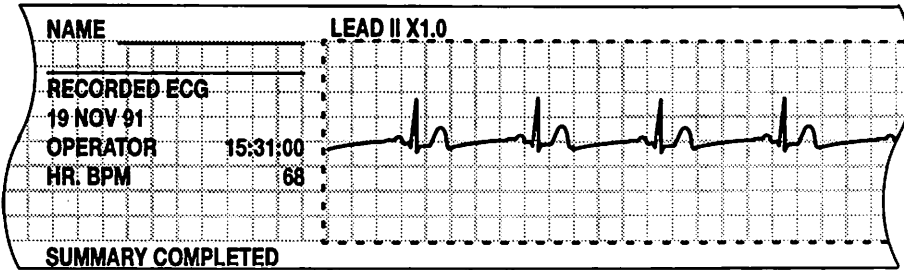
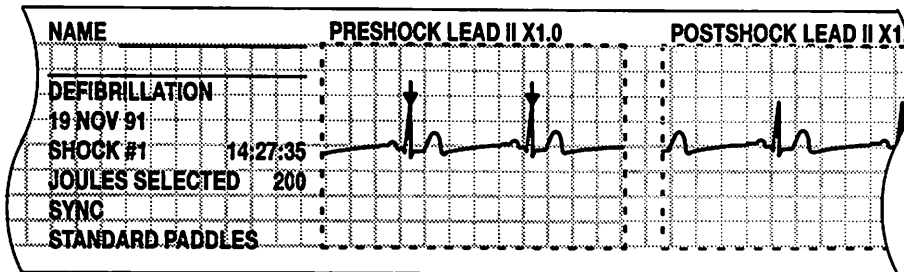


Figure 2 Example of CODE SUMMARY Printout

**Test and Calibration Procedure (TCP)**

The following tests *replace* tests in Service Manual TCP:

- Defibrillator Charge Check
- Defibrillator Calibration
- Test Load Calibration
- Charge Time
- Output Waveform

The following in Table 4 are additions to the TCP Test Equipment listed in the Service Manual:

**Table 4 Additional TCP Test Equipment**

Equipment	Specifications	Manufacturer
LIFEPAK 9 defibrillator/ monitor shock advisory adapter or defibrillation adapter	Calibrated	Physio-Control PN 803732 or 803747
Test Paddles	two	Physio-Control PN 803602

**⚠ WARNING**

**Shock hazard.** When charged and discharged during this TCP, the defibrillator discharges up to 360J of electrical energy through the defibrillator electrodes. Unless discharged safely as described in this TCP, this electrical energy may cause injury or death. Do not attempt to perform this procedure unless you are thoroughly familiar with the operation of the defibrillator.

**⚠ WARNING**

**Shock hazard.** Terminals and wires carrying high voltages up to +11.6kV are exposed with the instrument cases removed. Do not touch internal circuitry except as indicated in these procedures.

**CAUTION**

**Possible component damage.** PCBs in this instrument contain Static Sensitive Devices (SSDs). Use the Special Handling Procedures for Static Sensitive Devices described in Section 4 of your Service Manual to prevent build up of static charge. Refer to Table 5-1 in your Service Manual to identify PCB assemblies containing SSDs.

Defibrillator Charge  
Check

1. Remove the Front Panel (see the Disassembly Procedures in Section 4 of your Service Manual). Press the ON pushbutton on the Front Panel.
2. Use the DMM to monitor the voltage at the J3 pin 25 as shown in NO TAG (connect the DMM ground to J3 pin 7).
3. With the instrument power off, install the Shock Advisory Adapter or Defibrillation Adapter.
4. Remove the battery door on the bottom of the instrument and disconnect the battery. Connect the DC power supply to the battery connector inputs. Connect ground to pin 1 or 2 (black wire) and power to pin 3 4 (red wire).
5. Turn the instrument power on and initially set the power supply output to +18.00 ±0.05Vdc.
6. Charge the defibrillator to 360J.
7. Gradually reduce the power supply voltage toward the upper Low Battery Limit detection threshold of +15.22Vdc.
8. With the defibrillator cables attached to the test load connectors, press both adapter discharge pushbuttons.
9. Repeat steps 6. through 8. above, lowering the power supply voltage toward the lower Low Battery Limit detection threshold of +14.78Vdc until the **LOW BATTERY: CONNECT AC POWER** message is displayed. Confirm that the triggering voltage is within the Low Battery Limits shown in the Low Battery Thresholds Table.

10. Return the power supply voltage to  $+18.00 \pm 0.05\text{Vdc}$ .
11. Charge the defibrillator to 360J.
12. Slowly reduce the power supply voltage toward the upper Shutdown Limit detection threshold of  $+13.70\text{Vdc}$ .
13. Discharge the defibrillator into the internal test load of the defibrillator.
14. Repeat steps 8 through 10 above, lowering the power supply voltage toward the lower Shutdown Limit of  $+13.30\text{Vdc}$  until the CRT display blanks out. Confirm that the power supply voltage is within the Shutdown Limits shown in the Low Battery Thresholds Table.
15. Reinstall the Front Panel.

1. With the instrument power off, install the Shock Advisory Adapter or Defibrillation Adapter.
2. Attach the test paddles to the defibrillation cable and secure the paddles to the energy meter.

**CAUTION**

**Possible energy meter damage.** Start each test at the lowest energy level to avoid overheating the energy meter. Test each energy level in successive order.

3. Access the Test Menu (turn power off, then press ON while pressing and holding down LEAD SELECT and HR ALARM until the Test Menu is displayed).
4. Press ▼ ECG SIZE ▲ to scroll to the **DEFIB** test.
5. Press HR ALARM to start the **DEFIB** test.
6. Press ▼ ENERGY SELECT ▲ to scroll to **LOW**. Select 1J.
7. Press CHARGE.
8. After the instrument reaches full charge as indicated by the tone, simultaneously press both adapter discharge pushbuttons to transfer the energy into the energy meter.
9. Confirm that the CRT displays the message **JOULES DELIVERED: XXX**, where XXX is the energy selected.
10. Read the value on the energy meter.
11. Press ▼ ECG SIZE ▲ as necessary to change the **JOULES DELIVERED: XXX** value to match the value on the energy meter.
12. Press HR ALARM to enter the adjusted value.
13. Press CHARGE. After charging is complete, simultaneously press both adapter discharge pushbuttons to transfer the energy into the energy meter. Confirm that the energy meter value equals the selected value as indicated in Table 5.
14. Press HR ALARM to reinitiate the **DEFIB** test.
15. Repeat steps 6 through 14 for each energy level.

**Table 5 Defibrillator Calibration Measurement Ranges**

Selected Value (J)	Acceptable Range		Selected Value (J)	Acceptable Range	
	Value (J)	% Tolerance		Value (J)	% Tolerance
1	0.8 to 1.2	±20%	20	19.0 to 21.0	±5%
2	1.8 to 2.2	±10%	30	28.5 to 31.5	±5%
3	2.7 to 3.3	±10%	50	47.5 to 52.5	±5%
4	3.8 to 4.2	±5%	100	95.0 to 105.0	±5%
5	4.8 to 5.2	±5%	200	190.0 to 210.0	±5%
6	5.7 to 6.3	±5%	300	285.0 to 315.0	±5%
7	6.7 to 7.3	±5%	360	342.0 to 378.0	±5%
8	7.6 to 8.4	±5%			
9	8.6 to 9.4	±5%			
10	9.5 to 10.5	±5%			

TCP-Test Load  
Calibration

**Note:** Complete TCP-Defibrillator Calibration before performing this calibration of the test load

1. With the instrument power off, install the Shock Advisory Adapter or Defibrillation Adapter.
2. Attach the test paddles to the defibrillation cable and secure the paddles to the energy meter.
3. Access the Test Menu (turn power off, then press ON while pressing and holding down LEAD SELECT and HR ALARM until the Test Menu is displayed).
4. Press ▼ ECG SIZE ▲ to scroll to the **DEFIB** test.
5. Press HR ALARM to start the **DEFIB** test.
6. Press ▼ ENERGY SELECT ▲ to set the selected energy to 200J.
7. Press CHARGE.
8. After the defibrillator reaches full charge, simultaneously press the adapter discharge pushbuttons to transfer the energy into the test load.
9. When the CRT displays **JOULES DELIVERED: 200**, press HR ALARM.
10. Press LEAD SELECT to return to the Test Menu.
11. Scroll to **EXIT** and press HR ALARM to resume normal operation. Select **STD** lead.
12. Press CHARGE. After the defibrillator reaches full charge, simultaneously press the adapter discharge pushbuttons to transfer the energy into the test load.
13. Confirm that the CRT displays **TEST 200 JOULES DELIVERED**.
14. Confirm that the recorder prints the time and date followed by **TEST 200 JOULES DELIVERED**.

#### TCP-Charge Time

1. With the instrument power off, install the Shock Advisory Adapter or Defibrillation Adapter.
2. Attach the test paddles to the defibrillation cable and secure the paddles to the energy meter.
3. Press the defibrillator ON pushbutton.
4. Press ▼ ENERGY SELECT ▲ to set the selected energy to 360J.
5. Simultaneously start the timer and press CHARGE.
6. Stop the timer when the defibrillator reaches full charge. Confirm that the time required to reach full charge is less than 10 seconds.
7. Simultaneously press both adapter discharge pushbuttons to transfer the energy into the test load.

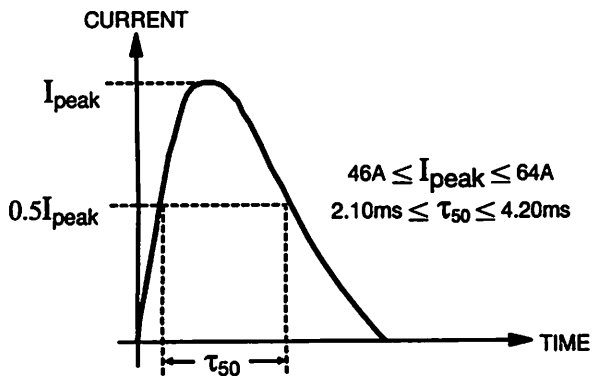
#### TCP-Output Waveform

1. With the instrument power off, install the Shock Advisory Adapter or Defibrillation Adapter.
2. Attach the test paddles to the defibrillation cable and secure the paddles to the energy meter. Place the APEX paddle on the right electrode of the energy meter so that the pulse polarity is positive.
3. Connect the storage oscilloscope to the energy meter signal output.
4. Set up the oscilloscope for the "single shot" acquisition mode for the pulse waveform capture. Refer to the Operating Instructions for the oscilloscope for assistance. For waveform parameter measurement, place both the left and right measurement markers at both the 50% and 10% levels.
5. Press the defibrillator ON pushbutton.
6. Press ▼ ENERGY SELECT ▲ to select 360J.
7. Press CHARGE.

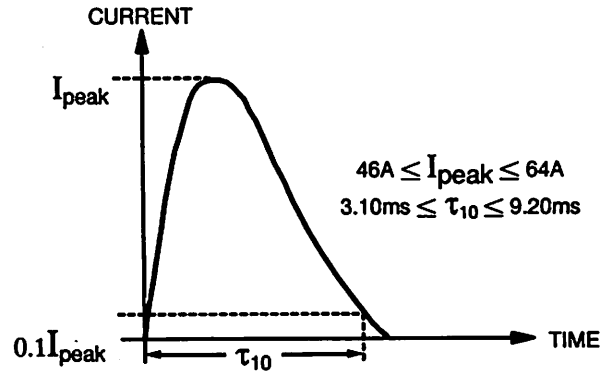
8. After the defibrillator reaches full charge, simultaneously press the adapter discharge pushbuttons to transfer the energy into the energy meter.
9. Inspect the waveform displayed on the oscilloscope and confirm that the waveform meets the specifications listed below and illustrated in Figure 3.

Peak current = 46A to 64A peak  
 Time above 50% = 2.10ms to 4.20ms  
 Time above 10% = 3.10ms to 9.20ms

**PEAK CURRENT – TIME ABOVE 50%**



**PEAK CURRENT – TIME ABOVE 10%**



**Figure 3 Output Waveform**